

FS2

Installation & Operation Guide

Version 2.1

Published: July 12, 2013



Because it matters.™

AJA[®]
VIDEO SYSTEMS

Table of Contents

Notices	9
Trademarks	9
Copyright	9
Contacting Support	9
Chapter 1: Introduction	10
Overview	10
Video Features	10
3G Support	11
Audio Features	11
Other Features	11
Typical Applications	11
FS2 Control	12
Front Panel Control	12
Remote Web Browser Control	12
GPI Inputs and Outputs	12
SNMP Interface Monitoring	12
Optional FS2 Features	12
Fiber I/O	12
Dolby E Decoder Card	12
Technical Description	13
Video Processors	13
Audio Processors	14
In This Manual	14
Chapter 2: Controls, Indicators, and Connections	15
Control and Indicator Descriptions	15
Front Panel Description	15
Alphanumeric Display	16
Operational Summary	16
Pushbuttons	16
Control Knobs	18
LED Indicators	19
Incompatibility Alarms	20
Incompatible Video Formats	20
Example Reference and Video Incompatibility Alarms	21
Rear Panel Description	21
Connectors	21
About Inputs and Outputs	22
Chapter 3: Installation & Configuration	24
Installation Overview	24
Installation Summary	25
Unpacking	26
Shipping Box Contents	26
Installing Optional Fiber Optic I/O Modules	27
Installing Optional Cards	27
Dolby Decoder Installation	28
FS2 Chassis Installation	28
Physical Requirements for Mounting the Chassis	28

Chassis Dimensions	28
Cabling and Cooling Requirements	28
Power Requirements	28
Networking	28
FS2 Default Network Settings	29
Networking Using DHCP or Default Static IP	30
Networking the FS2 Using Your Own Static IP	30
Using Ping to Test the Network Connection	32
Mac Ping Procedure	33
Windows PC Ping Procedure	33
Web Browser Control	33
Software Update Installation	33
Download the Latest FS2 Software	33
Unpack the Software	34
Uploading and Installing the Software to the FS2	34
System Cabling	35
System Video/Audio Cable Connections	35
GPI Connections	35
FS2 Audio Level Choices—Pro or Consumer, US or EBU	35
Computer Video Formats	36
Physical Connection	36
Menu Setup	37
Scaling	37
Genlocking	37
Getting Your Computer Working with the FS2	38
Achieving the Highest Output Quality	38
Chapter 4: Display Menus	39
Controlling the FS2 via Front Panel Display Menus	39
Parameter Menus	39
Menu Group Buttons	40
SELECT and ADJUST Knobs	40
Menu Operation Examples	41
Status Pages	41
Simple Menu: Config Format Alarm Filters	41
Multiple Parameter Menus: Video 1 ProcAmp	42
Multiple Field Parameters: IP Address	43
STATUS Menu Group	44
S.1 I/O Status	44
S.2 Vid1 Format Status	44
S.3 Vid1 Format Alarm Status	44
S.4 Vid2 Format Status	45
S.5 Vid 2 Format Alarm Status	45
S.6 Output Status	45
S.7 Power/Temp Alarm	45
S.8 Caption Status	45
S.9 Dolby Status	46
S.10 Dolby Framer Status	46
S.11 System Name	46
REMOTE Menu Group	46
1 Remote Control	46
1.1 Authentication	47
2.1–4 GPI IN 1–4 Response	47

3.1–4 GPI 1–4 OUT	48
Interaction of Presets and GPIs	48
Example of a Serial Recall	49
Example of an Unintended Recall.....	49
CONFIG Menu Group	49
1 System Name	49
Name Entry Procedure	49
2.1 IP Config	49
2.2 IP Address.....	50
Octet Value Entry Procedure	50
2.3 Subnet Mask	50
2.4 Default Gateway.....	50
3 MAC Address (view only)	50
SNMP Menu Parameters.....	50
5 Power Supply Alarm.....	51
6.1 Vid1 Format Alarm.....	51
6.2 Vid2 Format Alarm.....	51
7 Reference Alarm.....	51
8 Hidden Menus	52
9 Screen Saver	52
10 Display Intensity	52
11 Fan Speed	52
12 Serial Number.....	52
13 Software Version	52
14 Reboot	52
PRESET Menu Group.....	52
1 Factory Preset	53
1.1–1.40 Presets #1–#40	53
Interaction of Presets and GPIs	53
SYSTEM Menu Group	53
1 Component In Format.....	53
2 Component Out Format	54
3 Analog Audio Std	54
4 SDI1 3G Detect	54
5 SDI2 Input Protect.....	55
6 Fiber1 3G Detect	56
7 Fiber2 Input Protect	56
8 Genlock Source	56
9 Frame Rates.....	56
10 NTSC Standard.....	57
11 Composite Downconv.....	57
12 HDMI RGB Range.....	57
14.0 AES/EBU SRC Mode.....	57
14.1–14.8 AES/EBU SRC.....	58
15 Dolby Decoder Input.....	59
16 Dolby Decoder Mode	59
17 Dolby Decoder Aux Out	59
18 Dolby Decoder Aux Mode	60
OUTPUT Menu Group	60
1.1 SDI1 Video Out	60
1.2 SDI2 Video Out	60
2.1 Fiber1 Video Out	61
2.2 Fiber2 Video Out	61

3 HDMI Video Out	61
4 Component Out	61
5 Composite Out	61
6 HDMI Audio Out	61
7 AES/EBU Audio Out	61
8 Analog Audio Out	62
9.1 SDI1 3G Config	62
9.2 SDI2 3G Config	62
10.1 Fiber1 3G Config	62
10.2 Fiber2 3G Config	62
VIDEO 1 and VIDEO 2 Menu Groups	62
Video Input and Output	63
1 Video Input	63
2 Output Format	63
3 Video Output Mode	64
Background Fill	64
4 Background Fill	64
Loss of Input	64
5 Loss of Input	64
Upconvert and Downconvert	64
6 Upconvert Mode	64
7 Downconvert Mode	65
Aspect Ratio	67
8 SD Aspect Ratio Convert	67
Sidebars	68
9 Sidebar Edge	68
Matte of Background Fill	69
10.1 Matte Luma	69
10.2 Matte Chroma	69
10.3 Matte Hue	69
Proc Amp Controls (YUV)	69
11.0 Proc Amp (YUV)	69
11.1 Proc Amp Gain	69
11.2 Proc Amp Black	69
11.3 Proc Amp Hue	69
11.4 Proc Amp Sat	70
Color Corrector (RGB)	70
12.0 Color Corrector (RGB)	70
12.1 Color Red Gain	70
12.2 Color Red Black Level	70
12.3 Color Red Gamma	70
12.4 -12.6 Color Green	70
12.7-12.9 Color Blue	70
Custom Conversion Settings	70
13.0 Custom Size/Pos	71
13.1 Custom Size	71
13.2 Custom Aspect	71
13.3 Custom H Position	71
13.4 Custom V Position	71
13.5 Custom Left Crop	71
13.6 Custom Right Crop	71
13.7 Custom Top Crop	71
13.8 Custom Bottom Crop	71

Region of Interest (ROI)	72
14.0 Region of Interest	72
14.1 ROI Left	72
14.2 ROI Right	72
14.3 ROI Top	72
14.4 ROI Bottom	72
Timing and Delay	73
15.1 Output Timing H	73
15.2 Output Timing V	73
15.4 Extra Frame Delay	73
Video Legalizer	73
16.0 Video Legalizer	73
16.1 Legalizer White Clip	73
16.2 Legalizer Black Clip	74
16.3 Legalizer Chroma Clip	74
AFD	74
17.1 AFD Out SDI 1/2	74
17.2 AFD VANC Output Lines	75
17.3 Downcvt AFD Dflt	75
Closed Captioning	75
18 Caption Xlator	75
Input Scan and PSF	76
19 Input Scan Format	76
SD Line 21 Closed Caption Blanking	76
20 SD Line 21 Blanking	76
Test Pattern	77
21 Test Pattern Video	77
Freeze	77
22 Freeze Output	77
AUDIO 1 and AUDIO 2 Menu Groups	77
1.0 Audio Input	78
1.1–1.16 Audio Map Ch1–16	79
1.17–1.24 Audio Map Ch 1/2–15/16	80
2 Embedded Audio Out	80
3 Audio Follow Video	80
4 Audio Signal Gen	81
Audio Delay Controls	81
6.0 Audio Delay (mS)	81
6.1–16 Audio Delay Ch1–16 (mS)	82
6.17–24 Audio Delay Ch1/2–15/16(mS)	82
Audio Output Level Controls	82
7.0 Audio Out Levels	82
7.1–7.16 Audio Level Ch1–16	83
Audio Output Phase Controls	83
8.0 Audio Output Phase	83
8.1–8.16 Audio Phase Ch1–16	83
Dolby Framer Controls	83
9.0 Dolby Framer Sync	83
9.1 Dolby Framer Input	84
9.2 Dolby Framer Offset (Frames)	84
9.3 Dolby Framer Offset (Samples)	84
Chapter 5: Browser Remote Control	85

Remote FS2 Control Via a Web Browser	85
General Web Browser Screen Description	85
Controlling Multiple FS2s	86
Resetting Values To Factory Settings	86
Drop Down Parameter Operation	87
Slider Operation	87
Video Format Display	87
Screen Descriptions	87
Network Pane and Network Configuration Screen	88
IP Address Type	88
IP Address	89
Netmask	89
Default Gateway	89
Alarm Configuration Screen	90
Status Screen	90
System Screen	92
Config Screen	93
System Name	93
SNMP Parameters	93
Hidden Menus	94
Display Intensity	94
UPnP Host	94
UPnP Proxy	94
Presets Screen	95
Presets Screen Controls	95
Factory Preset	95
Recall	95
Store	95
Export	96
Import	96
Export Presets 1–40 (All)	96
Import Presets 1–40 (All)	96
Interaction of Presets and GPIs	96
Output Screen	96
Video 1 & 2 Screens	97
Audio 1 and 2 Screens	98
Remote Screen	99
Firmware Screen	100
Chapter 6: SNMP	101
FS2 Simple Network Management Protocol	101
SNMP Configuration	101
Front Panel Screens	101
Front Panel Octet Value Entry Procedure	102
Web Browser	102
SNMP Configuration Parameters	103
4.0 SNMP Enable	103
4.1 SNMP Trap Destination 1	103
4.2 SNMP Trap Port 1	103
4.3 SNMP Trap Destination 2	103
4.4 SNMP Trap Port 2	103
Appendix A: Specifications	104
Video Format Conversion	104

Video Input/Output Formats.....	104
Video A/D, D/A Converters.....	106
Audio.....	106
Interfaces.....	106
Physical.....	107
Appendix B: FS2 Pinouts.....	108
GPI Pinouts.....	108
Audio Connection Pinouts.....	109
Analog Audio.....	109
Digital Audio.....	109
Appendix C: Safety & Compliance.....	110
Federal Communications Commission (FCC) Compliance Notices.....	110
Class B Interference Statement.....	110
FCC Caution.....	110
Canadian ICES Statement.....	110
European Union and European Free Trade Association (EFTA)	
Regulatory Compliance.....	111
Declaration of Conformity.....	111
Korea KCC Compliance Statement.....	112
Taiwan Compliance Statement.....	112
Chinese Compliance Statement.....	112
Translated Warning and Caution Messages.....	112
Before Operation Please Read These Instructions.....	113
Index.....	119

Notices

Trademarks

AJA®, KONA®, Ki Pro®, KUMO® and XENA® are registered trademarks of AJA Video, Inc., Ki Pro Mini™, Io Express™, Io HD™, Io™ and “Work. Flow.” are trademarks of AJA Video, Inc. AirPort, Apple, the Apple logo, AppleShare, AppleTalk, FireWire, iPod, iPod Touch, Mac, and Macintosh are registered trademarks of Apple Computer, Inc. Final Cut Pro, QuickTime and the QuickTime Logo are trademarks of Apple Computer, Inc. Avid, Avid Media Composer and Avid DNxHD are trademarks of Avid Technology, Inc. All other trademarks are the property of their respective holders.

Copyright

Copyright © 2013 AJA Video, Inc. All rights reserved. All information in this manual is subject to change without notice. No part of the document may be reproduced or transmitted in any form, or by any means, electronic or mechanical, including photocopying or recording, without the express written permission of AJA Inc.

Contacting Support

When calling for support, have all information at hand prior to calling.

To contact AJA Video for sales or support, use any of the following methods:

Telephone: +1.800.251.4224 or +1.530.271.3190

Web: <http://www.aja.com>

Support Email: support@aja.com

Sales Email: sales@aja.com

Chapter 1: Introduction



Overview

Featuring a flexible, “anything-in, anything-out” architecture, the dual-processor FS2 Universal Video/Audio Frame Synchronizer and Format Converter simultaneously works with two independent channels of 10-bit broadcast quality video and two independent groups of 16-channel audio.

The FS2 can be used as two separate Frame Synchronizers/Format Converters, or the two channels can be combined in many powerful ways—for example, sidebar keying where both the video and background graphics can be upconverted and combined.

The FS2 supports analog and digital I/O, with full input and output crosspoint matrices, allowing any I/O port to be assigned to either processor. With support of all broadcast video formats, the FS2 makes matching up disparate video and audio systems simple—one converter box does it all.

Video Features

- The FS2 handles a wide variety of video formats. See ["Appendix A: Specifications on page 104"](#) for a complete list.
- Dual video format converters, each featuring SD/HD (up/down), SD-to-SD (aspect ratio), and HD-to-HD (720/1080 cross) conversions.
- Dual video processors supporting proc amp and color correction.
- Dual frame synchronizers.
- Dual video/key framestores downloadable from the local area network.
- User-specified custom format conversion and scaling with variable crop, size, aspect, position, and Region of Interest parameters.
- Dual flexible keyers for video/key overlays or sidebar keying from the two video processors, the two internal video/key framestores, or internal matte generators.
- Closed captioning support, featuring true conversion between EIA 608 and 708 (SD and HD) CC formats.
- Active Format Description (AFD) support.
- Scan convert computer formats via a DVI-to-HDMI cable
- Dual 3G/HD/SD SDI I/O with embedded audio.
- Dual 3G/HD/SD Optical Fiber I/O (optional).

- HDMI I/O supporting 3D HDMI output.
- Component/Composite analog HD/SD video I/O, 12-bit.
- Looping reference input with flexible genlock.

3G Support The FS2 supports several types of 3G video (and some associated embedded audio):

- 1080p59.94/1080p50 in both SMPTE level A or level B
- Muxed 3G Video: two separate 720p/1080i video signals muxed into one 3G level B signal
- Dual-Link Video in the form of 1080p59.94/1080p50 video on two 1.5G SDI cables.

In the case of Dual Link Video, the FS2 input processing can demux the two signals and send them (each with their associated 16-channel audio) to the two processors. For output, the FS2 can mux together the two video signals (and their audio) from the two processors into a Dual Stream 3G video output.

Control of 3G functionality can be set to automatic (using ANC data format ID), or with full manual control via the user interface.

Audio Features

- Dual audio processors, each supporting 16-channel audio with full channel mapping.
- 16-channel AES/EBU, 8-channel balanced analog I/O.
- 16-channel embedded audio I/O with full mapping.
- AFV (audio follows video) support.

Other Features

- Built-in front panel control via scrolling alphanumeric and graphical menu.
- Front panel LED status indicators for at-a-glance system monitoring.
- Linux operating system supporting full network compatibility, including Web-based remote control over 10/100/1000 Ethernet via an internal web server.
- Two fully redundant power supplies standard.
- Five-year international warranty with unlimited technical support.

Typical Applications

The FS2 can be used in a very wide variety of video and audio signal conversion, adaptation, timing, and processing applications:

- Up/down/cross conversion between many SD and HD formats, including 1080p50/60.
- General purpose video frame synchronization.
- Analog-to-Digital and Digital-to-Analog audio/video conversion.
- Mux or Demux two separate HD signals from one 3G SDI signal.
- Convert 3G/HD/SD video over fiber to/from SDI (BNC).
- Use the built-in video processing amplifiers to adjust and/or color correct.
- Synchronize the timing of key and fill signals by putting both through the parallel FS2 video processors and adjusting their timing independently. Then key them using one of the two FS2 keyers or an external keyer.
- Use the HDMI input and a DVI-to-HDMI cable to scan-convert popular computer video formats to SD or HD, including full proc-amp functionality and aspect ratio adjustment.
- HD sidebar keying including using both SD video and SD sidebar graphics (analog or digital), upconverting both, and combining—all in the FS2.

FS2 Control

FS2 operation can be monitored and changed in a number of ways. Feature sets in each of the control methods vary, although the front panel and web browser interfaces offer many of the same features.

Front Panel Control

The FS2 front panel offers the most direct control, ideal for use in machine rooms or wherever quick changes and status checks must be made. The buttons and knobs control menus in the display, allowing you to fully configure the system according to your purposes. You can control inputs, outputs, processing paths, keying, and much more.

Remote Web Browser Control

The FS2 internally contains an optimized web server that allows remote monitoring and parameter setting via an Ethernet 10/100/1000 network-attached computer running a web-browser. Networks can be closed local area networks, a straight computer-to-FS2 cable, or for greatest flexibility, exposed through a firewall to a broadband WAN. From a network-connected computer you can communicate with one or more FS2 devices, even getting them to identify themselves via LEDs on the front and rear panel.

GPI Inputs and Outputs

General Purpose Inputs and Outputs are available on the FS2 back panel to provide contact closure control. Using the inputs, an external contact closure activates a specified function on the FS2. Using the outputs, specific FS2 functions can produce a contact closure to activate any desired function on external equipment. The functions to be activated by an input or that can activate an output are set using the front panel and browser menus.

SNMP Interface Monitoring

SNMP offers remote network monitoring of alarm conditions.

Optional FS2 Features

Fiber I/O

The FS2 supports optional AJA Optical Fiber I/O modules as follows:

- Single Input, LC connector
- Single Input SC connector
- Single Output LC connector
- Single Output SC connector
- Dual Input LC connectors
- Dual Output LC connectors

FS2's Fiber I/O supports the 3G/HD/SD SDI protocol. Only AJA modules are supported; use of other manufacturers' modules is not supported and may void the warranty.

Dolby E Decoder Card

The current FS2 software supports a Dolby E Decoder option in the right-hand option slot under the option top cover.

Technical Description

The FS2 features an incredibly flexible architecture offering two identical Video/Audio processing units, both of which can access any input or drive any output. For Video processing, each processor can also access the other video processor for sidebar keying or other functions that involve both video signals. For audio processing, each audio processor has access to any audio input for full channel mapping capability, and each audio processor outputs a 16-channel group that can be embedded in the SDI/HDMI/Fiber outputs and/or sent to the AES or Analog outputs.

Figure 1. FS2 Simplified Block Diagram

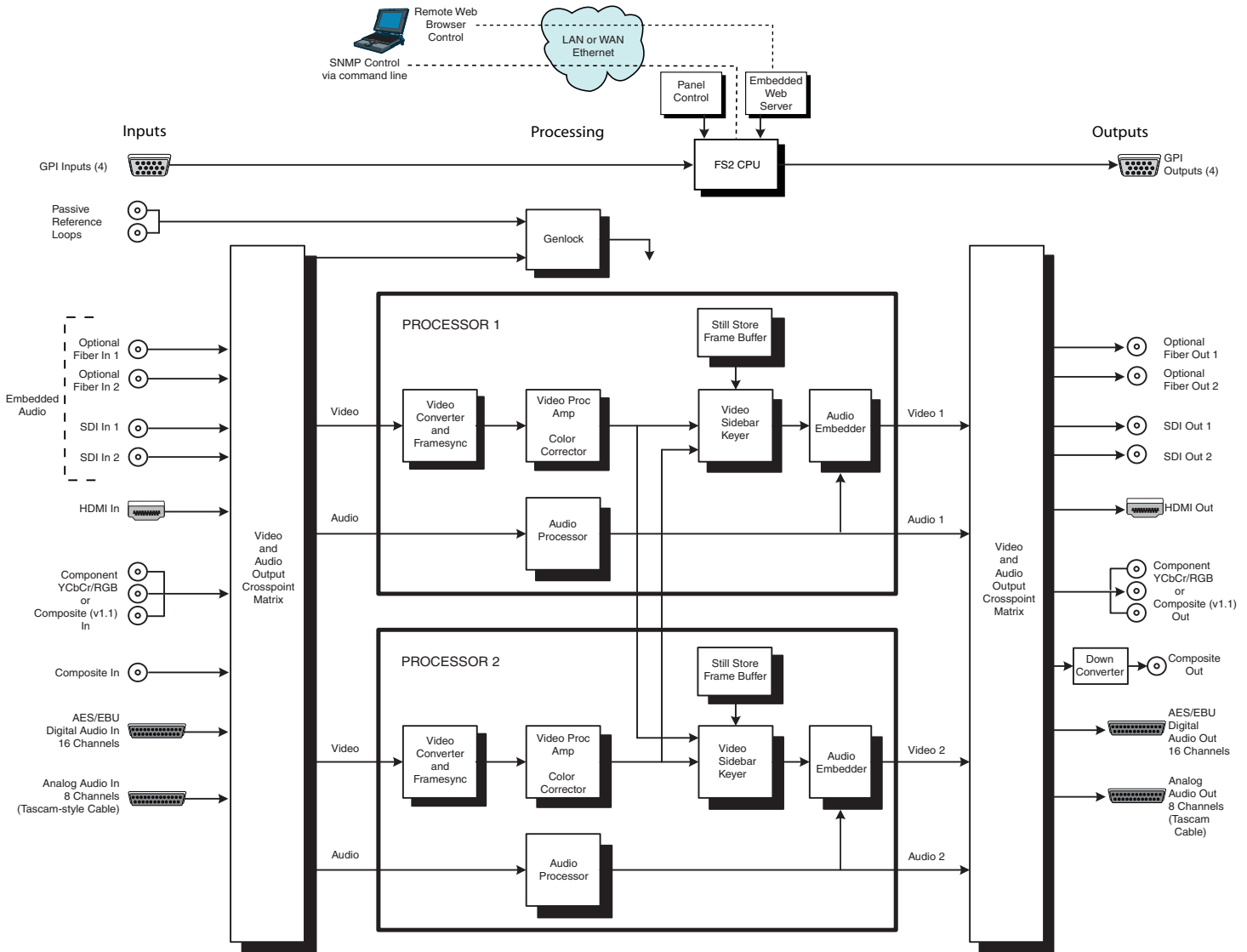

Video Processors

The two Video Processors are identical and perform format conversion, frame synchronization, signal processing, and keying operations. Each video processor has access to any video input from the Input Crosspoint Matrix.

Up, down, or cross conversion is done with very high quality scalars. De-interlacing is performed with high quality motion-adaptive processing including diagonal filters. The Processing Amplifier and Color Correctors support video signal adjustment with standard Proc Amp controls and RGB-style color correction.

The keys in each video processor can operate in several modes:

- Add a background for HD sidebar upconversion. The background can be Black, a user-configurable matte, video from the other video processor (which itself can be upconverted), or a video still (future firmware release) from the internal stillstore.
- Add a video/key graphic from the internal graphic stillstore (future firmware release)
- Combine the two video processors in various ways, such as creating a live “over-the-shoulder” key.

The Video Processors can also be used as a still store and output full screen stills or test patterns.

Audio Processors

The two audio processors accept analog, digital, or embedded audio inputs as chosen by the input crosspoint matrix. Inputs can be selected from Embedded (SDI, Fiber, or HDMI), AES, or Balanced Analog and full channel mapping supports any mixture of the inputs. Each audio processor processes and outputs 16 channels. The output of each processor can be embedded in its respective Video processor output (SDI, Fiber, or HDMI), or sent to the AES or Balanced outputs. For 3G and Dual link Inputs, the Audio processors can have access to all 32 channels.

In This Manual

Chapter 1: Introduction provides an overview and a list of box contents.

Chapter 2: Controls, Indicators, and Connections describes controls, indicators, and connections.

Chapter 3: Installation and Configuration provides complete instructions for installing and configuring the FS2.

Chapter 4: Display Menus explains how to use the FS2 controls and display menus.

Chapter 5: Browser Control explains how to use the FS2 remotely via a web browser on a network-attached computer.

Chapter 6: SNMP discusses FS2 support of SNMP.

Appendix A: Specifications presents a list of technical specifications for the product.

Appendix B: Pinouts explains the FS2 rear panel connector pinouts.

Appendix C: Safety & Compliance provides regulatory compliance statements, advisories and warnings.

Index

Chapter 2: Controls, Indicators, and Connections



Control and Indicator Descriptions

The controls, indicators, and connectors illustrated and described in this chapter allow you to connect, operate, and monitor the FS2 system and to troubleshoot problems if you encounter them. Becoming familiar with the FS2 front and rear panels also simplifies system installation, setup, and operation.

Additional control, indicator, and connector details follow in these chapters:

- Full installation instructions are provided in *Chapter 3*.
- Detailed menu descriptions are presented in *Chapter 4*.
- The web browser user interface is described in *Chapter 5*.

NOTE: *The AJA FS2 should be plugged into 3-wire 100-240 VAC 50/60 Hz power (autosensing) before you make connections to other equipment. The AC cords provide a path to ground for accidental static discharge to protect system equipment. The FS2 has two fully independent and redundant power supplies and will operate with one or both AC power cords plugged into the unit. However, fault-tolerance exists only if both power supplies are connected and plugged into separate branch circuits. Then if power is lost on a branch or one of the supplies, the FS2 will continue to operate on the remaining circuit and power supply.*



Warning!

To meet safety regulations for leakage current and to ensure redundancy in the event that a branch circuit breaker shuts off a branch, connect the FS2 dual power supplies to separate branch circuits.

Front Panel Description

The following topics present an overview of front panel controls and indicators to help you get familiar with operating the FS2. For details about using the controls with particular menus, please see *Chapter 4: Menus*.

Figure 2. AJA FS2 Front Panel Controls and Indicators

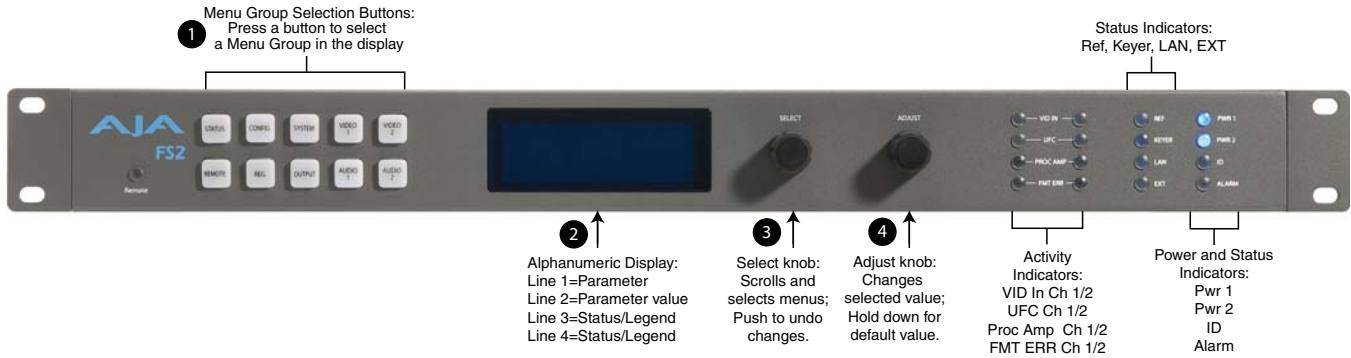

Alphanumeric Display

The FS2's control system is designed to be quick and easy to use. The four-line alphanumeric display shows menus that are numbered and grouped by function. The menu groups are easily accessed using pushbuttons which correspond one-to-one with the groups (one button per menu group). The menu lines, which are 23 characters wide, display the following information:

- **First line**—parameter number and name.
- **Second line**—the editable value set for a parameter.
- **Third and fourth lines**—current status, labels, or prompts.

When you edit a parameter containing multiple values, such as the IP address, the value currently being edited blinks.

Operational Summary

The 10 front panel pushbuttons allow you to select display menu groups. The two knobs allow you to change menus and set parameters within the menu groups. These functions can be summarized as follows:

- Select a menu group: Press one of the ten pushbuttons.
- Scroll through menus in a group: Turn *SELECT*.
- Edit a menu parameter: Stop *SELECT* on the menu.
- Change a parameter value: Once the parameter is selected with *SELECT*, turn *ADJUST* to set the value. Changes apply in a few seconds.
- To edit a multiple part parameter, such as the IP address, push the *ADJUST* knob momentarily (the value blinks). To save the whole parameter after editing, push *ADJUST* momentarily again.
- Coarse adjust a value: Hold down the menu group button (the button turns blue) and turn *ADJUST*.
- Undo a change (restore previous setting): Push *SELECT* momentarily.
- Reset to factory default: Hold down *ADJUST* for 4 seconds.

Pushbuttons

These are the general rules of Menu Group button operation:

- Press one of the ten Menu Group buttons to access the associated menu group. The *SELECT* and *ADJUST* knobs control the display menus.
- The selected Menu Group button lights and the other buttons turn off.
- Each menu group returns to the last menu changed when you select the button. After a reboot, each group displays its first menu.

- Hold down a button (turns blue) to make coarse adjustments using the *Adjust* knob. Release the button to make fine adjustments.

The following text briefly lists the functions accessed by each pushbutton:

- STATUS** Displays the Status Menu Group, which shows current machine status and error conditions:
 - Video 1, Video 2, and Caption status
 - Reference and Genlock status
 - Output Status
 - Power and Temperature status
 - System Name display
 - Alarms
- REMOTE** Displays the Remote Menu Group, which lets you select how to control the FS2:
 - Control by local front panel, remote devices, or local and remote
 - GPI input and output behavior
- CONFIG** Displays the Config Menu Group, which lets you configure the FS2 for your environment:
 - System Name setting
 - IP and SNMP settings, MAC address
 - Alarm control
 - Hidden Menus and Display intensity (brightness)
 - System serial number and software version
 - System reboot
- PRESET** Displays the Reg Menu Group, which accesses the memory registers:
 - Store, Recall, and edit the names of Presets
 - Factory Preset (defaults)
- SYSTEM** Displays the System Menu Group, which lets you change or enable FS2 video and audio input and system functions:
 - Video input format settings, including 3G setup
 - Audio input format and sample rate conversion settings
 - Genlock reference source selection
 - Frame rate selection and NTSC standard (North America/Japan)
 - Input downconversion setting (HD to SD)
 - HDMI RGB Range
- OUTPUT** Displays the Output Menu Group, which selects output sources:
 - Composite downconversion
 - Video output selections
 - Audio output selections
 - 3 G output configuration
 - HDMI video and audio configuration
- VIDEO 1 and 2** Displays the Menu Groups that access Video Processor video input, format, and conversion selections and adjustments (separate buttons access Video Processor 1 and Video Processor 2):

- Video Processor Input Source and Background Fill selections
- Video Processor Output Format and Mode
- Loss of Input
- Video Processor Up, Down, Aspect, Edge, and Custom Conversions
- Video Processor Matte Adjustments
- Video Processor H and V timing
- Video Processor Proc Amp, Color Corrector, and Legalizer
- AFD embedding, input scan format (i or p), and caption translation
- Video Processor Test Patterns
- Freeze Output

AUDIO 1 and 2 Displays the Audio 1 Menu Group, which allows you to set Audio Processor 1 selections and adjustments:

- Audio Processor input selection, output embedding, and Audio Follow Video (AFV)
- Audio Signal Generator Selection
- Audio1 channel and stereo mapping
- Audio1 level, phase, and delay adjustments

Control Knobs

These are the general rules of *SELECT* and *ADJUST* knob operation:

SELECT Turning the SELECT knob performs these actions:

- Turn *SELECT* in either direction to scroll through the menus.
- Stop on a menu to enter that menu for editing.
- Turn *SELECT* within a menu to scroll through multiple parameters.
- Pause on a parameter to select it for editing. For multiple fields in a parameter, use *SELECT* to move through the fields (after pressing *Adjust* to enter field editing mode).
- Push *SELECT* momentarily to undo and restore the previous setting.

ADJUST Turning the ADJUST knob performs these actions:

- Turn *ADJUST* to change the values of a selected parameter.
- In most cases, leaving a value in place for a moment sets that value.
- To perform special actions, such as recalling a register, push the knob to confirm the displayed value. Display line 4 indicates such special actions.
- Some parameters having multiple fields, such as *IP Address* require you to push the *ADJUST* knob to select a field, and push again to save changes.
- Hold down the knob to reset a value to the factory default; for multiple field values, *all fields are reset to the default*.

Table 1. SELECT and ADJUST Knob Operation Summary

Function	Knob Action
Scroll through menus. Scroll through parameters in a multiparameter menu. Scroll through numerals or letters in a parameter.	Turn <i>SELECT</i> backwards or forward.
Enter edit mode for a menu. Enter edit mode for a parameter. Enter edit mode for values, numerals, or letters. Advance to the next value, numeral, or character to edit.	Turn and stop <i>SELECT</i> on the item to edit. (For some multiple parameter menus, push <i>ADJUST</i> so that the selected parameter blinks.)
Increment/decrement a value.	Turn <i>ADJUST</i> .
Coarse adjust a value.	Hold down button and turn <i>ADJUST</i> .
Reset a value to the factory default value. Set a number to the default value (typically zero). Set a letter to a default value (typically space).	Hold down <i>ADJUST</i> .
Take (commit) a change to an edited parameter.	Automatic after a few seconds for most parameters. For multiple field parameters, push <i>ADJUST</i> momentarily to save.
Abandon (undo) a change before committing.	Push <i>SELECT</i> momentarily.
Take (commit) a special action, such as a preset recall.	Push <i>ADJUST</i> momentarily.

NOTE: Menus and parameters are described in detail in Chapter 4.

LED Indicators

Indicators on the front panel are multi-state LEDs that light when a condition is present. They are conveniently arranged in groups to show specific subjects. For example, indicators for the two video processors are aligned in two columns with 1 and 2 labeling the tops of the columns.

The indicators and the conditions that cause them to light are as follows:

- REMOTE** A multicolor LED that indicates the current control mode:
- Green = Local Only (front panel control only)
 - Red = Remote Only (remote browser or panel control only)
 - Amber = Local + Remote (front panel and remote control both enabled)

VID IN 1/2 (blue) An active video input signal is detected for Channel 1 or 2.

UFC 1/2 (blue) The Universal Format Converter has been changed from the default setting for Channel 1 or 2.

PROC AMP 1/2 (blue) The Proc Amp has been changed from the default setting for Channel 1 or Channel 2 (it's no longer at unity).

FMT ERR 1/2 (red) The selected input and output formats are incompatible for Channel 1 or Channel 2.

REF (blue) The REF connector has an external reference video source applied.

KEYER (blue) Reserved for future use.

- LAN (blue)** The FS2 is connected to an operational local area network. This indicator lights momentarily when web browser selections are changed.
- EXT (blue flashing)** Flashes when a remote control source (remote panel or GPI) has initiated a change in the system.
- PWR 1/2 (blue)** Power Supply 1 or 2 is operational and receiving power. Both PWR 1 and PWR 2 LEDs must be lit to indicate redundant power is available.
- ID (blue)** Lights when you right-click on an FS2 system name in the web interface Network list. This action helps identify which FS2 you're controlling when multiple FS2 units are operated from a single computer. The ID LEDs on the front and rear panels perform the exact same function. No matter which side of a rack you're facing, you'll be able to see one of the LEDs.
- ALARM (red)** An alarm event has been detected. Press the STATUS button for information. The Alarm LED may light because of a disconnected or failed power supply, other hardware failure, video incompatibilities, or genlock loss. (Any of these conditions may be suppressed using the Alarm Suppress parameters, CONFIG 5, 6.1, 6.2, and 7.)

Incompatibility Alarms

The FS2 produces signal incompatibility alarms for a number of reasons. The following tables explain how to interpret the alarms.

Incompatible Video Formats The table below shows conversions that the FS2 cannot do and which will cause video format alarms to be generated.

Table 2. Incompatible Video Formats

Input	Incompatible Output Formats
525i59.94	1080p(&pSF)23.98
1080i59.94	1080p(&pSF)23.98
720p59.94	1080p(&pSF)23.98
1080p29.97	1080p(&pSF)23.98
1080pSF29.97	1080p(&pSF)23.98
625i60	1080p(&pSF)24
1080i60	1080p(&pSF)24
720p60	1080p(&pSF)24
1080p30	1080p(&pSF)24

Example Reference and Video Incompatibility Alarms

Video incompatibilities that the FS2 may detect include the following:

Table 3. Video Incompatibility Examples

Video Incompatibility Detected	Alarm Status screen will show		
Genlock Source is set to "Reference", but no Reference signal is detected.	VID1 BKGD GEN OUT	SDI 1 Matte Reference	525i59.94 No Input 1080i59.94
Genlock Source signal format is not compatible with selected Input Format.	VID1 BKGD GEN OUT	SDI 1 Matte Reference	Incompat Incompat 1080i59.94
Genlock Source signal format is not compatible with selected Output Format.	VID1 BKGD GEN OUT	SDI 1 Matte Reference	525i59.94 Incompat Incompat
Input signal is not compatible with selected Output Format.	VID1 BKGD GEN OUT	SDI 1 Matte Reference	Incompat 1080i59.94 Incompat

Rear Panel Description

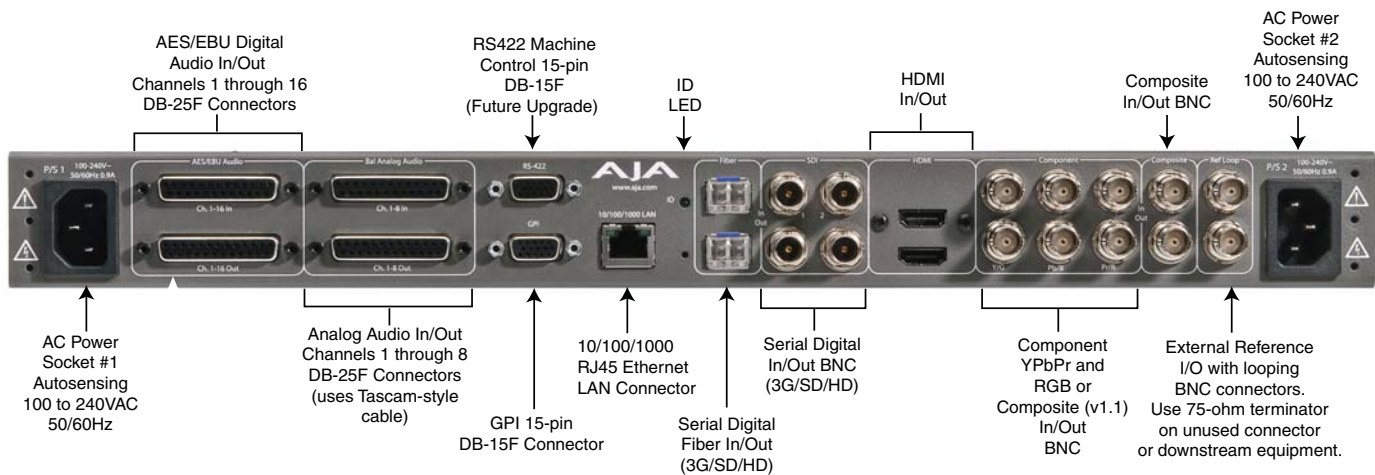

Connectors

The rear panel connectors are summarized below and described in detail in the next section:

P/S 1 and P/S 2 Two 3-pin grounded connectors provide AC power to the two independent power supplies. The supplies are autosensing for 100–240 VAC, 50/60 Hz. Only one connection is required for operation, but both connectors must be plugged into AC power for redundant power protection.

AES/EBU Digital Audio 16-Channel, 24-bit AES Input and Output on separate DB-25 connectors (Tascam pinout, see ["Audio Connection Pinouts"](#) on page 109).

Analog Audio Ch.1-8 In/Out	8 channel Balanced Analog Audio Input and Output on separate DB-25 connectors (Tascam pinout, see “Audio Connection Pinouts” on page 109). Audio A/D and D/A converters are 24 bit.
RS-422	DB-15 connector reserved for future use.
GPI	The GPI DB-15 connector provides connection to external equipment or circuits via an isolated TTL-compatible interface. Four GPI inputs and four outputs are available. See “GPI Pinouts” on page 108 . Using the <i>REMOTE</i> menu group, you can program the actions of the GPI inputs and outputs individually. Contact closures on the inputs can trigger a wide variety of FS2 functions. Alarms or loss of video can trigger the GPI outputs.
10/100/1000 LAN	This RJ45 connector provides an Ethernet 10/100/1000 port for connection directly to a computer or to a LAN through an Ethernet hub or switch.
SDI Fiber In/Out (optional)	Two optional Optical Fiber SFP modules support single- or dual-channel Fiber Input and/or Output. 3G/HD/SD SDI protocol is supported. Only AJA Optical Fiber SFP modules are supported—use of other manufacturer’s modules is not supported and may void warranty.
SDI In/Out	Digital video with embedded audio. Two SDI Input and two SDI Output BNCs. 10 bit 3G/HD/SD SDI is supported.
HDMI In/Out	HDMI In and Out is supported on HDMI connectors. Standard SD and HD video formats are supported, including support for 8 channel embedded audio. Also supports standard computer DVI video formats (input via a DVI to HDMI cable). HDCP (copy protected) HDMI video is not supported.
Component In/Out YPbPr/RGB Video	Component Analog Video is supported on 3x BNCs for Input and Output. Video A/D and D/A converters are 12-bit and support both SD and HD. YPbPr format is supported or the outputs can be switched to RGB. Additionally, with v 1.1 firmware composite analog video is supported.
Composite In/Out	Composite NTSC or PAL standard definition Input and Output. Composite Video A/D and D/A converters are 12-bit.
Ref Loop	he Reference Loop BNCs accept an Output timing reference signal. The reference can be SD Blackburst or HD tri-level sync. Examples of permissible reference video input signals: <ul style="list-style-type: none"> • 525 Color Black • 625 Color Black • 1080i Tri-level Sync • 720p Tri-level Sync <p>The 2 BNCs are a passive loop: one BNC is for the Input, and the remaining BNC can be connected to another piece of equipment in the reference chain or terminated.</p> <p><i>NOTE: For proper operation the input Reference signal must be stable and properly terminated using a 75-ohm terminator on either the unused loop connector or the last piece of downstream equipment to which the Ref Video is connected.</i></p>

About Inputs and Outputs

To operate the FS2, first select an Output Video Format (In the Video 1 or 2 menu); then select an Input port. The FS2 will automatically determine the selected input video format and convert it (if necessary) to the selected Output Video Format.

Any Video or Audio Input can be selected by either Processor 1 or Processor 2, and either processor's output can be sent to any output port.

The composite Video Output has a dedicated Downconverter so it can always display an output even if it is selected to output an AV Processor that is set to output HD.

Chapter 3: Installation & Configuration

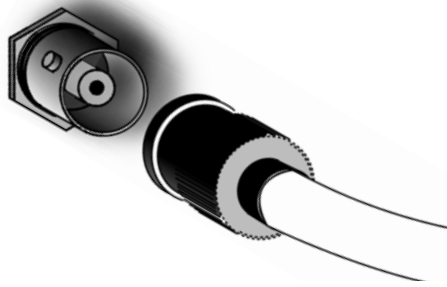



Installation Overview

The installation and set up of an FS2 is very simple. Plug both AC supply cords into AC mains power (separate branch circuits for redundancy), connect the LAN connector to a LAN, WAN or local computer with a web-browser, and then connect source and destination video and audio equipment.

	<p>Warning! High Voltage. This situation or condition can cause injury due to electric shock.</p>
---	--

	<p>Warning! Do not open the chassis. There are no user-serviceable parts inside. Opening the chassis will void the warranty unless performed by an AJA service center or licensed facility</p>
---	---

	<p>Warning! Disconnect the external AC power supply line cord(s) from the mains power before moving the unit.</p>
---	--

	<p>Warning! Do not defeat the safety purpose of the polarized or grounding-type plug. A polarized plug has two blades with one wider than the other. A grounding type plug has two blades and a third grounding prong. The wide blade or the third prong are provided for your safety. If the provided plug does not fit into your outlet, consult an electrician for replacement of the obsolete outlet.</p>
---	--

**Warning!**

Since the Mains plug is used as the disconnection for the device, it must remain readily accessible and operable.

**Warning!**

Protect the power cord from being walked on or pinched particularly at plugs, convenience receptacles, and the point where they exit from the device.

**Warning!**

To meet safety regulations for leakage current, connect the FS2 dual power supplies to separate branch circuits.

**Warning!**

Refer all servicing to qualified service personnel. Servicing is required when the device has been damaged in any way, such as power-supply cord or plug is damaged, liquid has been spilled or objects have fallen into the device, the device has been exposed to rain or moisture, does not operate normally, or has been dropped.

Installation Summary

All the steps of installation and configuration are documented in this chapter and are summarized as follows:

1. Unpack the shipping box, removing the FS2 and two power cords.
2. Install any physical options, such as fiber optic I/O modules or Dolby I/O cards.
3. Mount the physical chassis as desired: front rack, rear rack, or desk mount. If you are mounting multiple FS2 units, try to place them visually in the same area so you can use an attached computer to turn on and see the *ID* LED of the FS2 you're communicating with. For physical installation details, see ["FS2 Chassis Installation" on page 28](#).
4. Connect the two FS2 power cords to mains AC. For redundancy, use both power supplies and connect them to separate branch circuits so that the FS2 will continue to operate even if a circuit breaker opens on one branch.
5. If you plan to use remote control, connect your computer to the FS2 directly using an Ethernet cable, or connect both the computer and the FS2 to a local area network through an appropriate hub or router. Also set the FS2 IP address in the menus, and then use a computer to test (ping) the FS2 over the network connection to verify communication. For details, see ["Networking" on page 28](#).
6. Install a web browser on the computer, if not already present, for accessing the FS2 web pages. You can access the pages simply by entering the FS2 IP address in the browser address field. See ["Web Browser Control" on page 33](#) for details.

7. Connect the FS2 to system audio and video sources, including VTRs, monitors, DVD players, video switchers, and audio mixers. For details, see [“System Cabling” on page 35](#).
8. Test the FS2 with all of your devices to verify everything is working.

Unpacking

Shipping Box Contents

An FS2 chassis is shipped with two AC power cords, a user manual CD, and any late-breaking news bulletins (if applicable). Chassis rackmount brackets are provided as part of the chassis with screws.

Figure 3. Shipping Box Contents

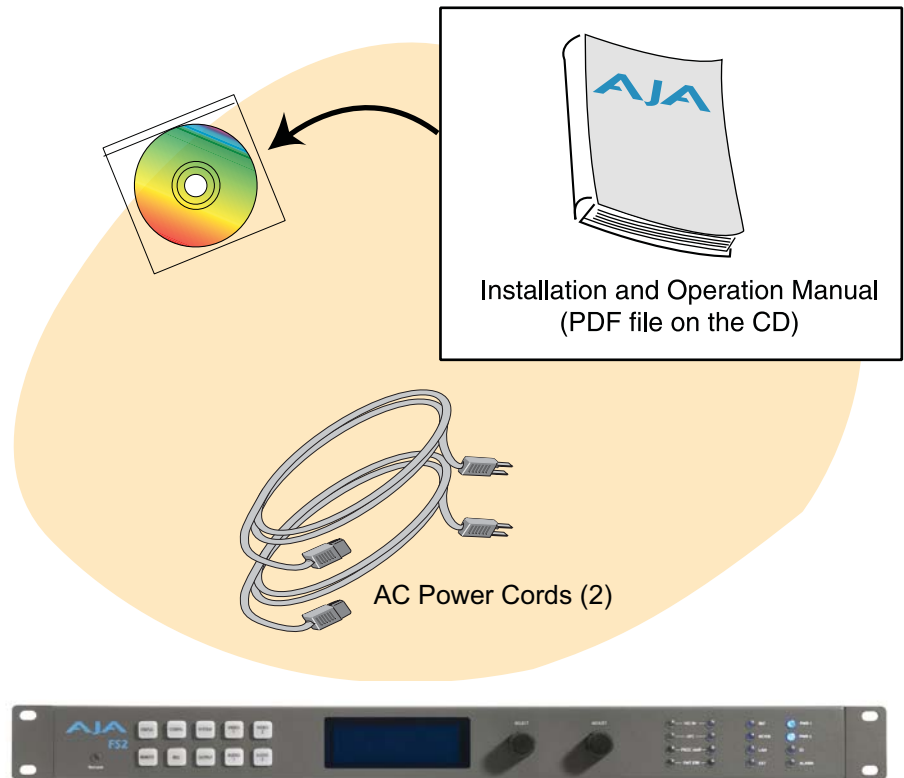

AJA FS2 Panel Chassis

As you unpack the shipping box, carefully examine the contents. Ensure you received everything and that nothing was damaged during shipment. If you find any damage, immediately notify the shipping service and supply them with a complete description of the damage. AJA will repair or replace damaged items.

If you find shipping damage, contact your AJA dealer or distributor for details on how to have your FS2 repaired or replaced.

NOTE: *Save packing materials and the shipping box. If your FS2 ever requires service or you move your system, use the packaging materials and box for safe shipment.*

Installing Optional Fiber Optic I/O Modules

The optional AJA Fiber Optic I/O modules are purchased separately from the FS2. These AJA fiber modules work with the FS2:

- Single-channel LC connector modules
- Single-channel SC connector modules
- Dual-channel LC connector modules

	<p>Caution! Only AJA fiber optic I/O option modules may be inserted into the FS2 Fiber slots. DO NOT USE fiber modules from other manufacturers; they will damage the FS2 connectors and circuits.</p>
---	---

Install the optional fiber I/O modules by inserting them into the rectangular holes marked *Fiber* on the back panel with the electrical connectors facing downward. Press gently but firmly until the modules seat in the inside connectors. For additional installation and operation details, see the instructions provided with the fiber modules.

Installing Optional Cards

Optional cards install in the two option slots on the FS2 circuit board. Access them by removing the small top cover as explained and illustrated below:

1. Disconnect AC power.
2. Remove the four screws securing the small cover on top of the FS2.
3. Insert the cards into the card-edge connectors on the FS2 circuit board.
4. Insert the two supplied screws (with washers) through the holes in the cards into the mounting standoffs. Tighten the screws, being careful not to over tighten and damage the cards.
5. Replace the small cover and tighten down the screws holding it in place

Figure 4. Option Card Installation.

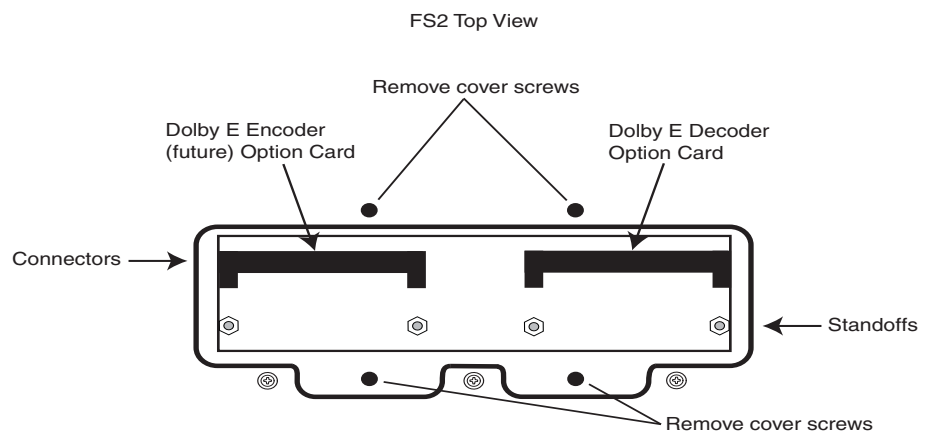

Dolby Decoder Installation The v1.1 software release supports Dolby Decoder cards in the right-hand option card slot. Disconnect AC power, remove the top panel option cover, and install the card in the right-hand slot as described above.

After installation, access the front panel or browser menus, and set these parameters as you prefer for the Dolby option:

- *System* parameters 15, 22.2, 22.3, and 22.4
- *Audio 1* and *Audio 2* parameters 1.0–1.24

FS2 Chassis Installation

The following information will help you install the FS2 chassis correctly.

Physical Requirements for Mounting the Chassis

You can mount the FS2 chassis in two ways:

- Rackmounting—attach the FS2 (rear or front mounted) to a standard 19-inch wide equipment rack. The chassis occupies only one vertical rack unit.
- Desktop—lay it on a horizontal flat surface.

Chassis Dimensions When planning the equipment location, consider the chassis dimensions:

- Height—1 rack unit, 1.75 inches (4.5 cm)
- Depth—16 inches (40.65 cm)
- Width—17.5 inches (44.45cm)
- Weight—7.85 pounds, 3.56 kilograms

Cabling and Cooling Requirements

Observe these precautions when placing your FS2:

- Plan adequate space for cable routing from the back of the chassis. Ensure that cable connectors are not stressed and cables are not bent or crimped.
- When rack mounting or stacking multiple FS2 chassis, ensure adequate airspace for cooling around the FS2 units. Note the location of cooling vents on all equipment next to the FS2 and ensure none are obstructed.

NOTE: FS2 units can be stacked vertically without limit as long as there is an adequate supply of cool air around the FS2 vents.

Power Requirements

The FS2 requires the following input voltage and power.

- Input Voltage—Chassis: autosensing 100VAC to 240VAC, 50/60Hz, fully redundant with both power supplies diode isolated.
- Power Consumption—55 Watts.

Networking

You can network the FS2 directly to a laptop or other desktop computer using a single Ethernet cable (straight or cross-over), or connect it to a local area network (LAN). In either case, the FS2 connects via its 10/100/1000 Base-TX Ethernet connector. A LAN is a shared network that includes other Ethernet devices all attached via a hub or digital

switch. LANs may be divided into zones separated by software or hardware routers. Routers may also be used to connect the LAN to an outside wide area network (WAN) such as the internet.

Devices on a LAN have IP addresses which may be fixed and permanent or dynamically assigned by the network (DHCP). When attaching the FS2 to a LAN, talk to your network administrator to find out how they want it connected (static IP or DHCP). Your IT department will be able to supply the information you need to install the FS2 on a LAN.

The following illustration shows a network connection example; your installation may differ.

Figure 5. FS2 Network Example, Two FS2s on a LAN, with Laptop for Remote Control

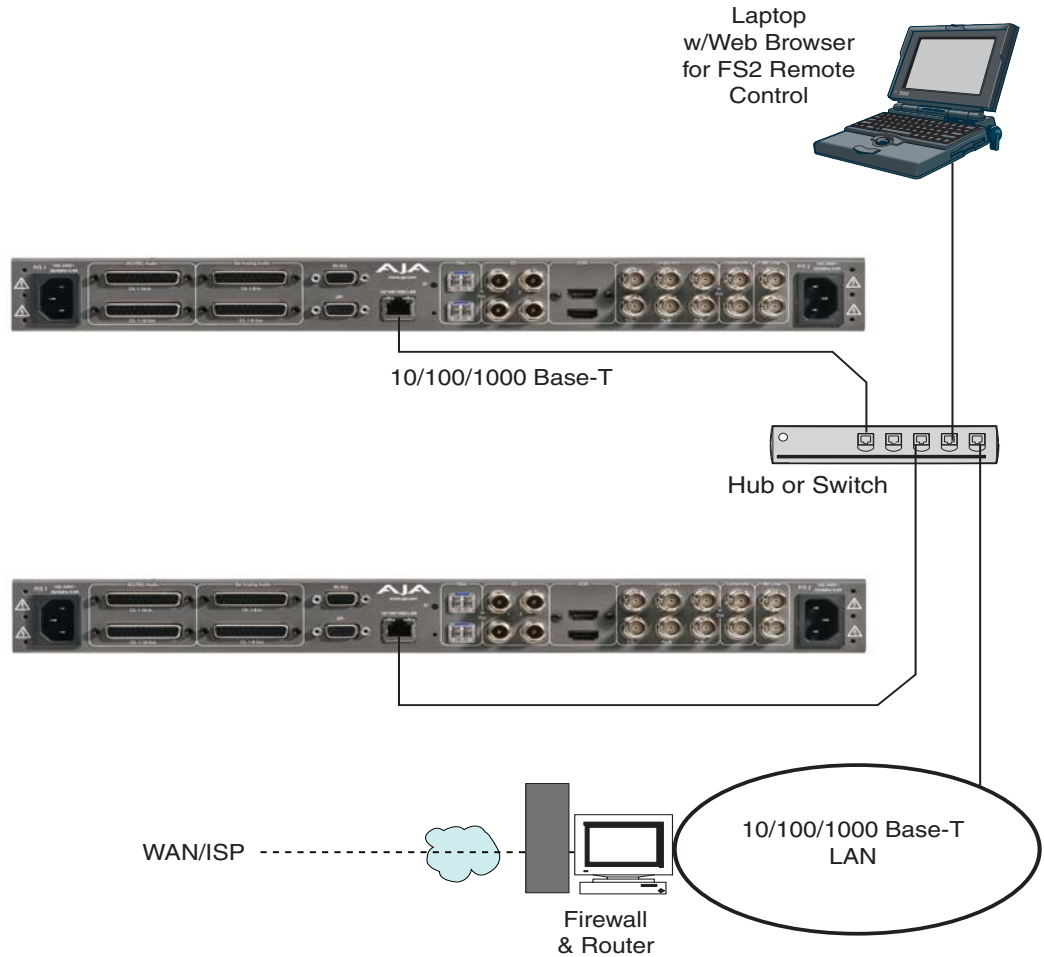

FS2 Default Network Settings

The FS2 ships from the factory set for DHCP networking, and can be manually reset to the following default network settings:

IP Address	192.168.0.2
Subnet Mask	255.255.255.0
Gateway	192.168.0.1

The following topics discuss two ways to set up the FS2 to communicate over a TCP/IP network connection: via DHCP or via a static IP address.

Networking Using DHCP or Default Static IP

The FS2 factory default configuration automatically looks for a DHCP server to issue an IP address. If your network includes a DHCP server, plug the FS2 into the network and connect with the FS2 as follows:

1. Press the *CONFIG* button.
2. Turn the *SELECT* knob to navigate to config parameter 2.2. Note on a piece of paper the DHCP-supplied IP address shown.
3. With your laptop or desktop computer connected to the same LAN as the FS2 and DHCP enabled, type the IP address you noted into the browser address field and press *Enter*. You should now see the FS2's browser *Status* screen.

If the FS2 cannot get an address from the network DHCP server, the FS2 will automatically use a preset factory static IP address of 192.168.0.2. You can access the FS2 using the default static address as follows:

1. Set your computer's IP address to whatever address you prefer.
2. Set the computer's Subnet mask to 255.255.255.0 (most PCs default to the proper netmask when the address is set).
3. Set the gateway address, if used, to match the FS2 default: 192.168.0.1. Alternatively, change the FS2 gateway address to match your gateway:
 - A. Press *CONFIG*, turn *SELECT* to 2.4 *Default Gateway*, push and then turn *ADJUST* to change the first group of digits.
 - B. Turn *SELECT* to advance to the next set of numbers, and turn *ADJUST* to set these numbers.
 - C. Continue using *SELECT* and *ADJUST* to set the full address.
 - D. When finished, push *ADJUST* momentarily to save the address.
5. Run a browser on the computer and type "192.168.0.2" (the factory static IP address). You should now see the FS2's browser status screen.

When you can access the FS2 screens, see "[Browser Remote Control](#)" on page 85 for details about configuring the FS2 using a browser.

Networking the FS2 Using Your Own Static IP

If you don't want to use DHCP or the default static IP address, you can set your own static IP address:

1. Select the *CONFIG* button and use the *SELECT* knob to navigate to parameter 2.1 *IP CONFIG*. Use the *ADJUST* knob to select *Static*.
2. Turn *SELECT* to navigate to parameter 2.2 *IP ADDRESS*. The display shows the default static IP address: 192.168.0.2.
3. Change the IP address as follows.
 - A. Push the *ADJUST* knob momentarily so that the first octet (set of numbers) blinks, and then turn *ADJUST* to change the numbers.
 - B. Turn *SELECT* to advance to the next set of numbers, and turn *ADJUST* to set these numbers.
 - C. Continue using *SELECT* and *ADJUST* to set the full address.
 - D. When finished, push *ADJUST* momentarily to save the address.

5. Turn *SELECT* to advance to *2.3 Subnet Mask*. Use the *SELECT* and *ADJUST* knobs as in the previous step to set the desired subnet mask.
6. Turn *SELECT* to advance to *2.4 Default Gateway*. Use the *SELECT* and *ADJUST* knobs as in the previous step to set the desired gateway address.
7. Run a browser on the computer and type in the IP address you set for the FS2. You should now see the FS2's *Status* screen.

When you can access the FS2 screens, turn to [“Browser Remote Control” on page 85](#) for details about configuring the FS2 using a browser.

Figure 6. Setting FS2 Static IP Address

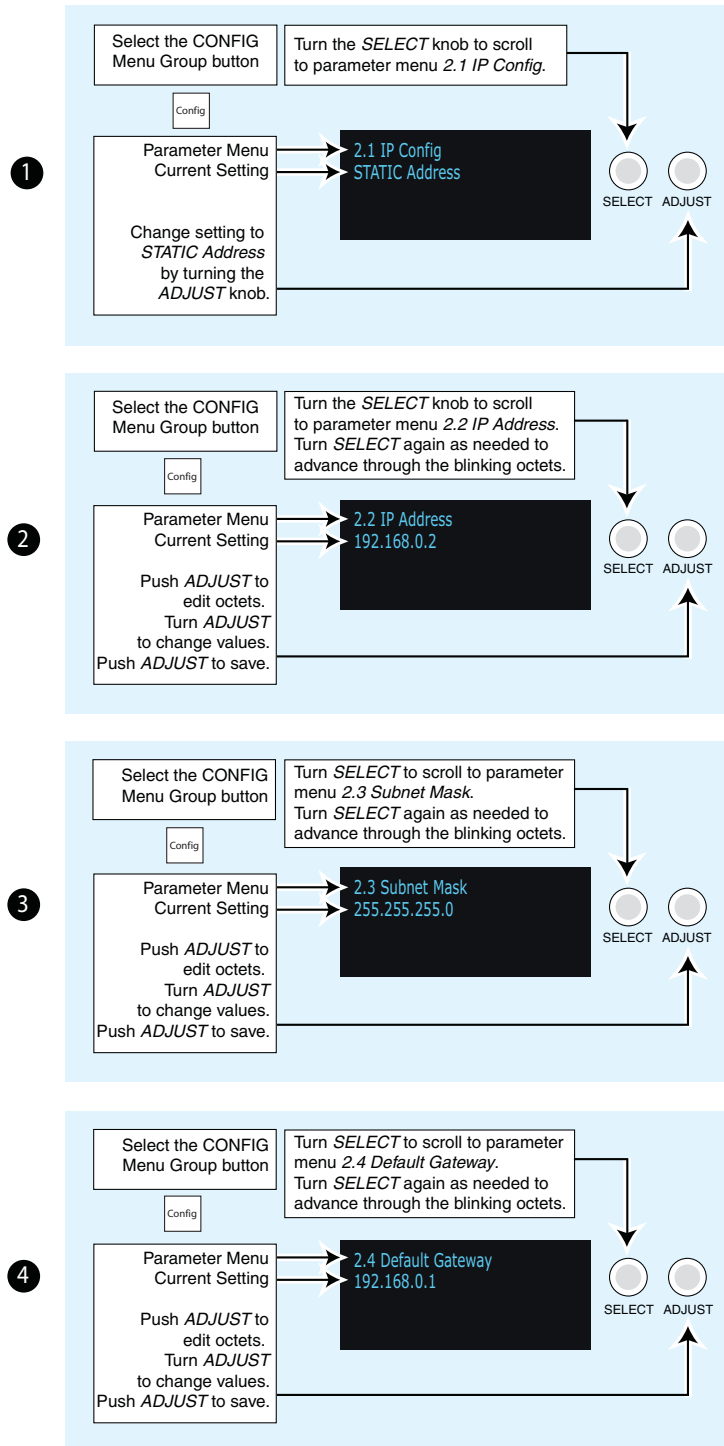

Using Ping to Test the Network Connection

If you have connected the FS2 to a computer and set up the IP address and still do not see the FS2 screens in your browser, you can ping the network to verify the connection. Simply run the Ping utility from a Mac OS X or Windows PC computer attached directly or on the same LAN as the FS2 as described below:

Mac Ping Procedure

1. Find the Utilities Folder inside of the Applications Folder.
2. Locate the "Terminal" utility application and double-click it.
3. On the FS2, select the *CONFIG* button and go to parameter menu 2.2 to read the IP address.
4. At the Mac terminal prompt, enter *ping* and the IP address noted in step 3.
For example: ping 192.168.0.2
5. If successful, the ping utility will respond that packets were sent, received and how long it took. For example:
64 bytes from 192.168.0.2: icmp_seq=0 ttl=64 time=0.590 ms
6. If unsuccessful, check the FS2 network settings and resolve the problem with your IT administrator.

Windows PC Ping Procedure

1. From the Start button, select the All Programs menu.
2. Select Accessories/Command Prompt from the All Programs list.
3. On the FS2, select the *CONFIG* button and go to parameter menu 2.2 to read the IP address.
4. In the PC *Command Prompt* utility, enter *ping* and the IP address noted in step 3. For example: ping 192.168.0.2
5. If successful, the ping utility will respond that packets were sent, received and how long it took. For example:
64 bytes from 192.168.0.2: icmp_seq=0 ttl=64 time=0.590 ms
6. If unsuccessful, check the FS2 network settings and resolve the problem with your IT administrator.

Web Browser Control

To control the FS2 from a web browser on a network attached computer, enter the FS2 IP address as a URL in the browser. For example, if the FS2 IP address were "90.0.6.31", you would then type into the web browser: <http://90.0.6.31>. This topic is explained in greater detail in *Chapter 5: Browser Remote Control*.

NOTE: The webUI (browser GUI) will keep up with most changes initiated at the front panel. However, the webUI may not reconnect (displays "Disconnected") when network changes are initiated at the FS2 front panel. To manually reconnect, type the new IP address into the browser, or click the browser Refresh button. Sometimes the browser caches the old FS2 address. If you can't get the browser to connect, try clearing the Browser history to clear the cache, and then enter the new address again.

Software Update Installation

Although the FS2 comes from the factory pre-installed with software, it may not be as up-to-date as software posted on our AJA website. This topic describes the steps required to update the software in your AJA FS2.

Download the Latest FS2 Software

Current and past releases of FS2 software are available on the World Wide Web from AJA's website. To get the software, point your browser to the FS2 support page, which will contain helpful FS2 information and links to the updates

<http://www.aja.com/en/products/fs2/#support>

Once you're at the update page, you can select FS2 software files to download to your Mac or PC for upgrading your local FS2 machine.

Unpack the Software

FS2 software update files are "ZIP" files that you can open with a number of standard and third party file compression applications. The software image that you'll install on the FS2 is a file with a name like *FS2_ver_1.0.0.0.bin* or similar.

NOTE: Depending on your PC or Mac operating system settings, the ".bin" extension may not be visible to you in a file directory.

Uploading and Installing the Software to the FS2

Uploading and installing the software update requires a PC or Mac that can "see" the FS2 via its Ethernet connection. Follow this procedure to install the software:

1. Point your browser at the FS2's upgrade page by clicking on the *Update Firmware* link at the bottom of the navigation box on the left-hand side of any FS2 web page. The FS2 web pages are discussed in *Chapter 5*

Figure 7. Update Firmware Browser Screen.

After entering the Firmware menu, click Browse and follow the prompts.

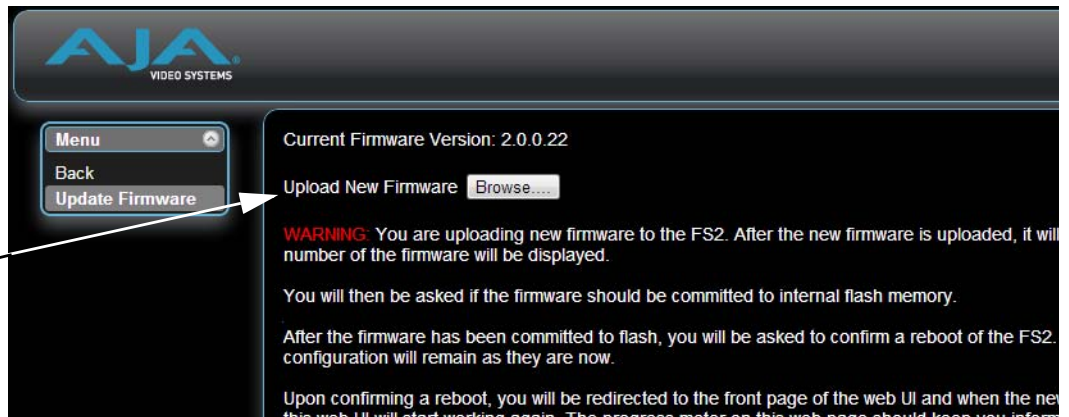

2. Click the *Browse...* button to find and select the downloaded file. For example: *FS2_ver_1.0.0.10.bin* contained in the file downloaded from AJA.
3. Click *OK* when asked if you want to *Upload Firmware*. The file uploads to the FS2 and is tested for validity. Incomplete, corrupted, or non-FS2 files are rejected. Wait for the procedure to complete—it will take only a few minutes. Progress bars show upload progress.
4. Click *Commit Uploaded Firmware* when prompted after the upload is finished. Progress bars show progress as the file is written to flash memory.
5. Click *Restart FS2 with New Firmware* to restart the FS2. This will take the FS2 offline for a minute or two. During the restart, progress is shown in the connection area in the upper right corner of the FS2 *Status* screen. After restart, the FS2 will be running the new software.
6. Once these steps are complete, the FS2 will be running the software, and the *Software Version* on the *Status* screen shows the new version number. Check that the new software is running by bringing up the FS2 web page again; the software version is displayed at the top of all FS2 web screens. If the FS2 did not update successfully, run through the update steps again.

NOTE: *The configuration of the FS2 prior to the upgrade is preserved. The unit returns to service exactly as it was before the upgrade.*

If there is a power outage or glitch during the software download, the FS2 will boot the older software version and you can restart the upgrade process. This happens because the FS2 has been designed with a safety feature where an internal “safe” copy of the previous software is retained in the event the updating process fails.

System Cabling

System Video/Audio Cable Connections

When installing your system, you’ll make video and audio input/output connections. These connectors are explained individually in *Chapter 2*.

GPI Connections

The FS2 has four GPI inputs and four GPI outputs. The GPI inputs and outputs are electrically isolated from the power and ground on the FS2 frame. Electrical isolation is provided for up to four pieces of external equipment.

See *“GPI Pinouts” on page 108* for information on how to wire the GPI connector to work with external devices that you want to use to control the FS2 or that you want the FS2 to control.

FS2 Audio Level Choices—Pro or Consumer, US or EBU

Since the FS2 handles both digital and analog audio and can convert between the two, it provides analog and digital audio level settings in the front panel menus and the remote web browser. Standard practice typically sets the maximum audio level approximately 20 db above the operating (alignment) level, allowing enough headroom to handle peaks without clipping. Because different countries and equipment types use different operating and maximum levels, the FS2 has several audio level settings. These settings allow you to set the relationship between the analog and digital audio levels to accommodate the equipment and audio operating standards you use.

The FS2 offers four settings shown in the following table. The analog audio levels listed in the table are defined in reference to 0 dBFS (where FS = full scale), which is the maximum level that can be represented digitally. Note that the test method for these levels uses a 1kHz sine wave.

Table 4. FS2 Audio Level Settings

FS2 Audio Setting	Meaning
+24 dBu analog = 0 dBFS maximum audio level	<p>SMPTE standard (US) With digital audio at the maximum possible level (before clipping), the expected analog audio input level is +24 dBu, and the output is scaled to this level.</p> <p>Typically, the US Standard Operating Level is +4 dBu analog or -20 dBFS digital. The FS2 +24 dBu setting allows 20 dB of headroom (+4 to +24 dBu) per the SMPTE RP-155 standard.</p>
+18 dBu analog = 0 dBFS maximum audio level	<p>EBU standard (EU) With digital audio at the maximum possible level (before clipping), the expected analog audio input level is +18 dBu, and the output is scaled to this level.</p> <p>Typically, the EU Alignment Level is 0dBu analog or -18 dBFS digital. The FS2 +18 dBu setting allows 18 dB of headroom (0 to +18 dBu) per the EBU R68 standard.</p>
+15 dBu analog = 0 dBFS maximum audio level	<p>German standard With digital audio at the maximum possible level (before clipping), the expected analog audio input level is +15 dBu, and the output is scaled to this level.</p>
+12 dBu analog = 0 dBFS maximum audio level	<p>Consumer equipment With digital audio at the maximum level (before clipping), the analog audio input level is +12 dBu, and the output is scaled to this level. These levels are provided for consumer equipment that outputs lower audio levels than professional equipment.</p> <p>Consumer audio units are often given in dBV, with +12.2dBu equivalent to +10dBV. The standard operating level corresponds to -10dBV (-7.8dBu). The FS2 +12dBu setting provides approximately 20 dB of headroom (+10 to -10 dBV).</p>

Computer Video Formats

The AJA FS2 accepts non-broadcast video input signals with the introduction of software version 2.0. These signals, known as “computer,” “VESA,” or “DVI” formats, can be applied to the HDMI input connector. Computer signals applied to the HDMI input must be digital video signals compatible with single-link DVI, which covers the range of display sizes from 640x480 (VGA) to 1920x1200 (WUXGA). For a list of accepted computer video formats, please see ["Appendix A: Specifications on page 104"](#).

Note: The FS2 does not accept analog computer video inputs because HDMI connectors do not have pins assigned for analog signals. The FS2 also does not accept dual-link DVI inputs.

Physical Connection

To connect a computer video input to the FS2 HDMI connector, use a passive DVI-to-HDMI adapter (user supplied). To prevent strain on the FS2 HDMI connector, AJA recommends that you convert from DVI to HDMI at the video source, such as the computer display card, and run an HDMI cable from the source to the FS2 input. You can

also use a cable adapter that has a DVI connector on one end of the cable and an HDMI connector on the other. The FS2 HDMI input connector is a terminating input and does not have a “loop-through” output.

Menu Setup

To enable a computer input in the FS2 menu system, select HDMI as the input using Video Menu 1 for the Video Processor channel you plan to use. The FS2 will automatically detect the frame format of the incoming video and scale/convert the input to the selected output format. You can select the same HDMI input for both Video Processors and independently convert the input to separate video output formats.

Scaling

If the DVI source video frame aspect ratio is not the same as the output video format frame aspect ratio, the FS2 scales the input frame size based on the current Upconvert (Video Menu 6) or Downconvert (Video Menu 7) mode selection.

If the FS2 output format is set to a Standard Definition (SD) format (525i/59.94 or 625i/50), the current Downconvert mode is used to determine the frame scaling mode.

If the FS2 output format is set to a High Definition (HD) format (anything other than SD), the current Upconvert mode will be used to determine the frame scaling mode.

Table 5. Scaling Applied With Downconvert or Upconvert Mode Selected

Downconvert Mode	Upconvert Mode	Frame Scaling
Letterbox	4x3 Pillar	Scale the input frame until the longer dimension (H or V) touches the output raster edges. The shorter dimension is filled with background video. Maintains the original pixel aspect ratio.
Crop	Wide Zoom	Scale the input frame until the shorter dimension (H or V) touches the output raster edges. The longer dimension is cut off (cropped) to fit the output frame. Maintains the original pixel aspect ratio.
Anamorphic	Full Screen	Scale the input frame independently in H and V until both dimensions fill the output raster. No cropping or background fill is required, but the original pixel aspect ratio may be “stretched” to fill the output raster.
14x9	14x9 Pillar	Compromise between Letterbox and Crop modes: some background fill may be required in the shorter dimension to fill the output raster (but not as much as Letterbox mode), and some cropping may be required in the longer dimension to fit the output raster (but not as much as Crop mode). Maintains the original pixel aspect ratio.
Auto AFD	LB to Full	When used with “computer format” inputs these modes default to Letterbox / 4x3 Pillar behavior.

Genlocking

The FS2 does not genlock (synchronize) to computer format video inputs. If a computer video input feeds Video Processor 1 or 2 and the current Genlock Source (System Menu 8) is set to Vid1 Input or Vid 2 Input, the system automatically defaults to Free Run mode. You can select Reference as the Genlock Source and apply a broadcast video signal to the Reference input if you wish to genlock to video rather than use Free Run mode.

Getting Your Computer Working with the FS2

Getting your computer to work with the FS2 is much like getting your computer to work with a second monitor. Here's the recommended procedure:

1. Turn off the computer and the FS2.
2. Connect the computer video output to the FS2 HDMI input.
3. Turn on the FS2 and wait for it to boot completely.
4. Turn on the computer and wait for it to boot completely.
5. In the Windows 7 "Display" Control Panel, navigate to "Screen Resolution," and confirm that a second monitor for the FS2 is displayed. Click on the "FS2" monitor and adjust the settings as desired.
6. For Mac OS computers, open the System Preferences application, and click on the "Display" icon (in the Hardware row). Click the FS2 monitor window and adjust the settings as desired.

Achieving the Highest Output Quality

To achieve the highest quality FS2 video output from a computer input, two processes must work together: (1) the computer display card must be set to scale the computer video output to the highest possible resolution and image size, and (2) the FS2 must be set to convert the computer video to the closest matching resolution in a broadcast format. If the computer is set for a small video output format, such as 640x480 VGA, and the FS2 converts that to 1080i, the result is a scale down by the computer card followed by a scale up in the FS2, causing a loss of resolution. Your results will be much better if you use a high resolution computer output and a closely matching FS2 conversion format.

Chapter 4: Display Menus

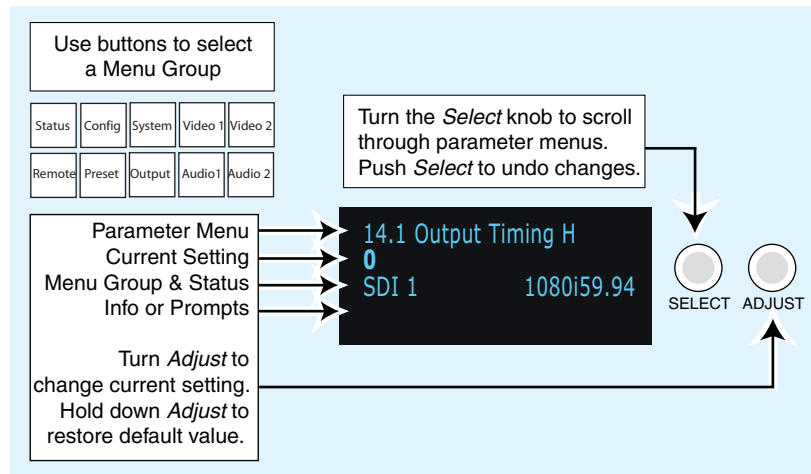

Controlling the FS2 via Front Panel Display Menus

There are three ways to control the FS2: (1) direct control using the front panel buttons, knobs, and display menus, (2) remote control using a web browser, and (3) remote control using an optional remote panel. This chapter describes the first, using the front panel controls, which is the most direct and all-inclusive way to configure and use an FS2. The other methods are described in subsequent chapters.

In *Chapter 2* we discussed the panel controls overall, so please read and understand that material first. In this chapter we discuss each of the Parameter Menus and their use. These are the topics covered:

- “*Menu Operation Examples*” on page 41
- “*STATUS Menu Group*” on page 44
- “*REMOTE Menu Group*” on page 46
- “*CONFIG Menu Group*” on page 49
- “*PRESET Menu Group*” on page 52
- “*SYSTEM Menu Group*” on page 53
- “*OUTPUT Menu Group*” on page 60
- “*VIDEO 1 and VIDEO 2 Menu Groups*” on page 62
- “*AUDIO 1 and AUDIO 2 Menu Groups*” on page 77

Parameter Menus

The front panel menu display contains four lines. These four lines present parameter menu “pages” used to configure and operate the FS2.

Each parameter menu page presents the following information:

First line—parameter number and name.

Second line—the editable value or values set for a parameter.

Third line and Fourth Lines—status, legends, or prompts. Not always used.

Figure 8. Four Lines of the Front Panel Display

```
1 Param number & name
2 Current value setting
3 Legend, info or prompt
4 Legend, info or prompt
```

The FS2 display presents five major types of menu pages:

- Status pages—present status information that cannot be changed.
- Simple parameter menus—contain a parameter number and name on line 1 and its current value setting on line 2. The line 2 value can be changed using *SELECT* and *ADJUST*. Example: *Output Format*.
- “Take action” parameter menus—contain a parameter number and name on line 1, and the value to “take” on line 2. A “take” prompt may appear on line 3. The line 2 value can be changed using *SELECT* and *ADJUST*, and the take or switch to the new value occurs when you press *ADJUST* momentarily. Examples: *Preset Save/Recall*.
- Multi-parameter menus—contain a parameter number and name on line 1 and multiple parameter values on line 2, each of which can be set separately using *SELECT* and *ADJUST*. In order to set all parameters, you must move to each parameter and set its value individually. Example: *Proc Amp* (to set Gain, Black Level, and Hue, you must select three separate parameters).
- Multiple field parameter menus—contain a parameter number and name on line 1 and its current value setting on line 2, consisting of multiple letter or number fields that must each be set individually. The line 2 fields can be changed using *SELECT* and *ADJUST*. Example: *IP Address*

Menu Group Buttons

As explained in *Chapter 2*, you enter a Menu Group whenever you push one of the ten Menu Group pushbuttons: STATUS, CONFIG, SYSTEM, VIDEO 1, VIDEO 2, REMOTE, REG, OUTPUT, AUDIO 1, and AUDIO 2. When you push a Menu Group button, the display changes to the selected menu group and shows the last viewed parameter menu.

Holding down any button enables coarse adjustment of the current parameter using the *ADJUST* knob.

SELECT and *ADJUST* Knobs

The *SELECT* and *ADJUST* knobs operate as follows:

- *Scroll menus*—Turn *SELECT* to scroll menus within the selected Menu Group.
- *Edit a menu*—Stop *SELECT* on a menu to select it for editing. If multiple values may be edited, such as an IP address, push *ADJUST* momentarily and then turn the *SELECT* knob to scroll through the values and select one for editing. The value blinks to indicate it is the one selected.
- *Change a value*—Turn *ADJUST* to change a value, number, or letter. Turning *ADJUST* forward (clockwise) or backward (counterclockwise) changes the value up or down, respectively. When you reach the end of the available values, the list starts over again at the beginning.
- *Make a coarse adjustment*—Holding down a Menu Group button enables coarse adjustment using *ADJUST* for wide-ranging values.
- *Undo a change*—Push *SELECT* during value editing to abort the edit and restore a value to its previous setting, if it has not already been saved.

- *Set factory default value*—Push and hold *ADJUST* for 4 seconds to set the parameter to its factory default value.
- *Save changes*—Parameter value changes are saved within a few seconds. For multiple values, such as IP addresses, push *ADJUST* momentarily (less than 4 seconds) to save or take parameter changes.

The remainder of this chapter presents menu examples followed by complete descriptions of the Menu Groups and Parameter Menus.

Menu Operation Examples

The following examples demonstrate typical menu operation. After this section, each Menu Group is described in detail.

Status Pages

These steps explain how to surf the *STATUS* menus.

1. Press the *STATUS* Menu Group button.
2. Turn the *SELECT* knob forward and backward to display the *Status* pages. The display scrolls through the pages as you turn the knob. The *Status* displays simply show the status of important FS2 operational parameters.

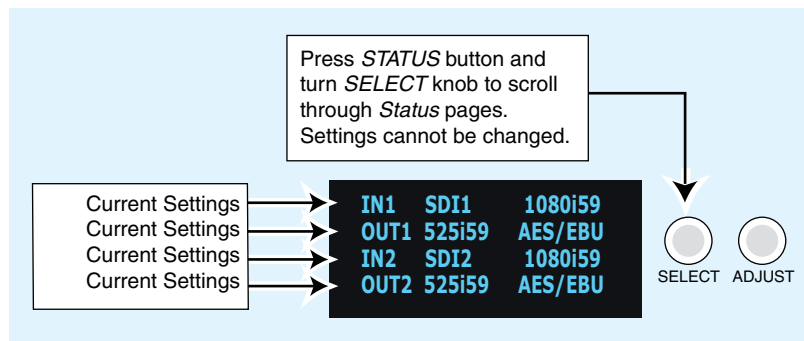

Simple Menus: Config Format Alarm Filters

These steps explain how to surf and change simple menus, such as the Power Supply Alarm Filters.

1. Press the *CONFIG* Menu Group button.
2. Turn the *SELECT* knob to access menu *5 Pwr Supply Alarm*. The default alarm setting is *Normal*.
3. Turn the *ADJUST* knob one click clockwise to change the setting to *Suppress*, which turns off the alarm so that it will never come on.
4. Turn the *SELECT* knob clockwise again to access menu *6.1 Vid1 Format Alarm*. Changing menus confirms the new *Pwr Supply Alarm* setting.
5. Now change the *Vid1* setting, using the *ADJUST* knob.

- Continue by turning *SELECT* one click to access the 6.2 *Vid2 Format Alarm* setting and again one click to access the 7 *Reference Alarm* setting. Change the settings using the *ADJUST* knob, if you wish.

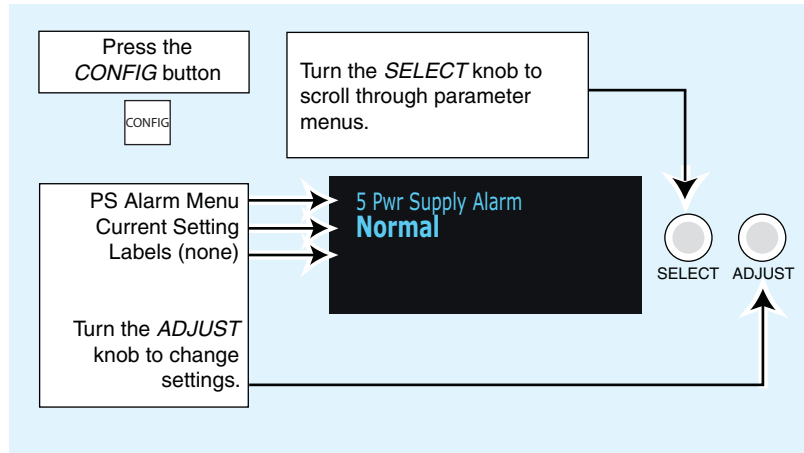

Multiple Parameter Menus: Video 1 ProcAmp

These steps explain how to surf and change multiple parameter menus, such as the *Vid1 ProcAmp* settings.

- Press the *VIDEO 1* Menu Group button.
- Turn the *SELECT* knob as necessary to display menu 11.0 *ProcAmp*.
- Turn the *ADJUST* knob to change the value setting from *OFF* (default) to *ON*.

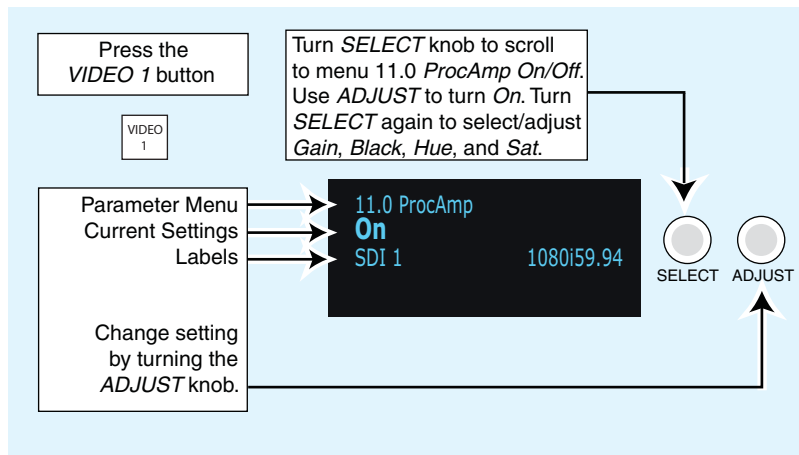

- Turn the *SELECT* knob clockwise to access menu 11.1 *ProcAmp Gain* and set the Gain as desired using the *ADJUST* knob.
- Turn the *SELECT* knob one click clockwise to confirm the setting and advance to the 11.2 *ProcAmp Black* menu. Turn *ADJUST* to set the black level.
- Turn the *SELECT* knob clockwise again one click to confirm the setting and advance to the 11.3 *ProcAmp Hue* menu. Turn *ADJUST* to set the hue.
- Turn the *SELECT* knob clockwise again one click to confirm the setting and advance to the 11.4 *ProcAmp Sat* menu. Turn *ADJUST* to set the saturation.

Multiple Field Parameters: IP Address

These steps explain how to surf and change multiple field parameter menus, such as the *IP Address* settings, where there are multiple fields to set within the value.

1. Press the *CONFIG* Menu Group button. The *Config* menus appear.
2. Turn the *SELECT* knob clockwise to access the *2.1 IP Config* menu. Turn the *ADJUST* knob to change the setting to *Static Addr*. This setting allows you to manually set the IP address in the following steps.
3. Turn the *SELECT* knob clockwise one click to access menu *2.2 IP Address*. The current IP address appears on the second line. For example: 10.2.42.8
4. Push the *ADJUST* knob momentarily to highlight the first field, which is the octet (group of numbers) to the left of the first period. The numbers blink to indicate they are ready for editing.
5. Turn the *ADJUST* knob to change the blinking field value.
6. Turn the *SELECT* knob to highlight the next field, a group of numbers to the right of the first period. The field will blink when they are ready for editing.
7. Turn the *ADJUST* knob to change the blinking field value. For coarse adjustment of wide-ranging values, hold down *CONFIG* and turn *ADJUST*.
8. Repeat this process of selecting fields and changing them until all fields have been changed as desired.
9. Push the *ADJUST* knob quickly to confirm all settings. Alternatively, you can scroll counterclockwise back through the fields, stopping on any of them to change them. They must be blinking before they can be changed.

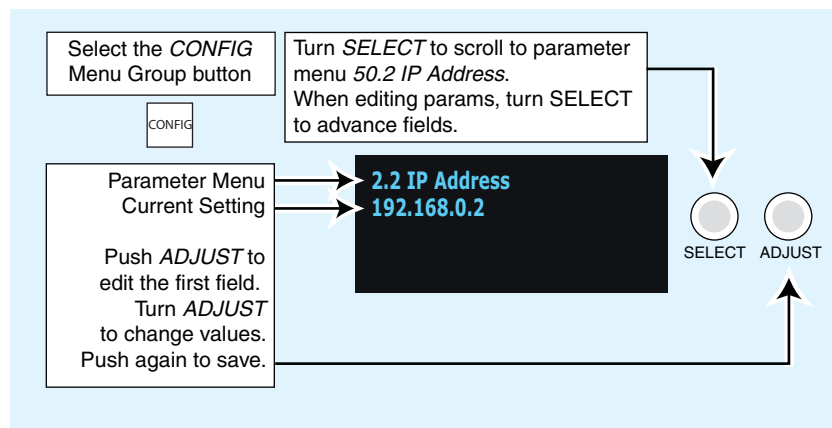

- Other Actions**
- To begin editing the first field in the parameter, push *ADJUST* momentarily.
 - To confirm (save) edits, push the *ADJUST* knob momentarily again. This saves the edits and exits the edit mode.
 - To undo edits to all of the fields before the changes are confirmed, push the *SELECT* knob. This returns all fields to their previous settings.
 - To reset the entire parameter to the factory default value, push in and hold down the *ADJUST* knob for at least 4 seconds.

STATUS Menu Group

The *Status* Menu Group contains a series of *Status* display pages that you can scroll using the *SELECT* knob. The various *Status* pages are actually just displays, not menus, since they don't include menu numbers or editable values. The *ADJUST* knob doesn't affect the *Status* display pages.

When you press the *STATUS* button, the display shows the first menu unless there is an active alarm. If an alarm is active, the relevant alarm status page is displayed first. If more than one alarm is active, the highest priority alarm page is displayed first.

NOTE: When displaying video format status, the following convention differentiates between SMPTE video formats (broadcast) and computer (VESA/DVI) formats (non-broadcast formats originating from a computer DVI signal). The SMPTE formats are shown as height (in lines), scan-format (progressive or interlaced), and frame-rate, such as 1080i59, for example. the VESA formats are shown as a size only, with an x in the middle, such as 640x480, for example.

S.1 I/O Status

This menu shows the current primary settings for Processors 1 and 2.

Display			Description
IN1	Sel Video	Format	Processor 1 selected video input and detected format.
OUT1	Sel Video	Audio	Processor 1 video output format and selected audio input.
IN2	Sel Video	Format	Processor 2 selected video input and detected format.
OUT2	Sel Video	Audio	Processor 2 video output format and selected audio input.

S.2 Vid1 Format Status

This menu shows the current primary settings for Processor 1.

Display			Description
VID1	Input Source	Format	Selected Processor 1 video input source and format.
BKGD	Backgd Source		Selected Background video source.
GEN	Genlock Source	Format	Selected Genlock source and format.
OUT		Format	Selected Processor 1 output format.

S.3 Vid1 Format Alarm Status

This menu shows the Processor 1 alarm status. Absence of alarm shows as *OK*. If selections are incompatible, the status of the affected signal shows *incompat*.

Display			Description
VID1	Input Source	Status	Selected Processor 1 video input source alarm status.
BKGD	Backgd Source	Status	Selected Background video source alarm status.
GEN	Genlock Source	Status	Selected Genlock source alarm status.
OUT		Status	Selected Processor 1 output format/alarm status.

S.4 Vid2 Format Status

This menu shows the current primary settings for Processor 2.

Display			Description
VID2	Input Source	Format	Selected Processor 2 video input source and format.
BKGD	Backgd Source		Selected Background video source.
GEN	Genlock Source	Format	Selected Genlock source and format.
OUT		Format	Selected Processor 2 output format.

S.5 Vid 2 Format Alarm Status

This menu shows the Processor 2 alarm status. Absence of alarm shows as *OK*. If selections are incompatible, the status of the affected signal shows *incompat*.

Display			Description
VID2	Input Source	Status	Selected Processor 2 video input source alarm status.
BKGD	Backgd Source	Status	Selected Background video source alarm status.
GEN	Genlock Source	Status	Selected Genlock source alarm status.
OUT		Status	Selected Processor 2 output format/alarm status.

S.6 Output Status

This menu shows the video source selected for each of the video outputs.

Display		Description
SDI1	Selected Video Processor	Selected Processor feeding the SDI 1 output.
SDI2	Selected Video Processor	Selected Processor feeding the SDI 2 output.
Fiber1	Selected Video Processor	Selected Processor feeding the Fiber 1 output.
Fiber2	Selected Video Processor	Selected Processor feeding the Fiber 2 output.
HDMI	Selected Video Processor	Selected Processor feeding the HDMI output.
Cmpn	Selected Video Processor	Selected Processor feeding the Component output.
Cmpn	Selected Video Processor	Selected Processor feeding the Composite output.

S.7 Power/Temp Alarm

This menu shows the power supply status of the FS2 and the temperature status. If a power supply is unplugged, the display top line indicates *PS OFF* or *PS Error*.

Display		Description
PS1 Alarm	Status	Displays the state of the PS1 power supply (OK or ERROR).
PS2 Alarm	Status	Displays the state of the PS 2 power supply (OK or ERROR).
TmpAlarm	Status	Displays a temperature alarm if the FS2 overheats.

S.8 Caption Status

This menu shows what type of closed caption data is selected and whether closed caption data is present on the selected video input.

Display		Description
VID1CC	Caption Type & Presence	Processor 1 selected caption type (SD/HD/Invalid) and presence (Detected/Not detected/Pass through).
ViD2CC	Caption Type & Presence	Processor 2 selected caption type (SD/HD/Invalid) and presence (detected/not detected/Pass through).

S.9 Dolby Status

This menu shows the FS2's Dolby Decoder settings.

Display	Description
DolbyDec	Status
DolBDecM	Status
DolBDAX0	Status
DolBDAXM	Status

S.10 Dolby Framer Status

This menu shows the current Dolby Framer status for Processors 1 and 2.

Display	Description
Aud1 State Status	Processor 1 Audio Dolby E Framer sync: Off, On, or Offset. For On or Offset, shows the selected channel pair.
Frm1 Status	Processor 1 Audio Dolby E Framer: Locked or Unlocked.
Aud2 State Status	Processor 2 Audio Dolby E Framer sync: Off, On, or Offset. For On or Offset, shows the selected channel pair.
Frm2 Status	Processor 2 Audio Dolby E Framer: Locked or Unlocked.

S.11 System Name

This menu shows the FS2's System Name, IP address and mask, and version number.

Display	Description
System Name	Displays the System Name as set in <i>Config</i> menu 1.
IP addr value	Shows the FS2's IP address.
IP Mask value	Shows the FS2's IP mask.
Version value	Shows the FS2's software version number.

REMOTE Menu Group

The *REMOTE* Menu Group lets you set up how you want the FS2 to be controlled. Control options include the front panel, a remote computer running a browser, and GPI inputs and outputs.

NOTE: *The Remote Menu Group parameters available on the front panel interact with the browser parameters available on an attached computer, and vice versa. For example, the Remote Control parameter can only be changed from the front panel, and when set to Local Only will deactivate all browser remote control parameters.*

1 Remote Control

This parameter determines whether the FS2panel responds to controls locally from the front panel, from a network attached computer with a web browser, or both. The selected mode is indicated by the color of the *REMOTE* LED.

Local + Remote (default)	Control the FS2 from the front panel, a remote control panel, or a network-attached browser. The <i>REMOTE</i> LED lights amber.
Local Only	Control the FS2 only from the front panel (browsers cannot change parameters). The <i>REMOTE</i> LED lights green.
Remote Only	Control the FS2 only from a network attached browser or remote control panel. The <i>REMOTE</i> LED lights red.

1.1 Authentication

This parameter enables or disables an authentication login requirement. By default this parameter is set to *Disabled*.

When you select *Login* via the front panel parameter, you must then go to the browser interface to perform a login each time you access the FS2. The browser presents the login screen first, requiring you to log in before you can access any other browser screens. The password is initially set to the default value, but you can change it using the Remote browser screen.

The default password is *password*.

NOTE: If authentication is used, it provides only a minimum security safeguard against unauthorized use of the FS2. The authentication mechanism is simple and does not provide robust security.

Disabled (<i>default</i>)	Disables the requirement for a login password. No password is needed.
Login	Login is required via the web browser interface before changes can be made in FS2 configuration.

2.1–4 GPI IN 1–4 Response

The setting of this parameter determines what happens when a GPI trigger is received at the FS2's GPI Inputs (1–4). A GPI Trigger is defined as a TTL low voltage level (0 to 0.8V with respect to its isolated ground pin). The GPI interface pinout and specifications are

discussed in [“GPI Pinouts” on page 108](#). Input video sources selected by GPI trigger remain selected until the trigger is released. GPI Inputs light the front panel EXT LED when triggered.

No Action (<i>default</i>)	Performs no action.
PRESET 1–10	Recalls the specified PRESET configuration.
Vid1 Freeze	Freezes the current video frame at its outputs. Freezing stops when the GPI trigger is released.
Vid1 SDI1 In	Selects SDI1 as the Vid1 video input.
Vid1 SDI2 In	Selects SDI2 as the Vid1 video input.
Vid1 SDI DLink	Selects Dual-Link mode for the SDI input.
Vid1 Fiber1 In	Selects Fiber1 as the Vid1 video input.
Vid1 Fiber2 In	Selects Fiber2 as the Vid1 video input.
Vid1 Fbr DLink	Selects Dual-Link mode for the Fiber input.
Vid1 HDMI In	Selects HDMI In as the Vid1 video input
Vid1 Cmpst In	Selects Composite In as the Vid1 video input.
Vid1 Cmpnt In	Selects Component In as the Vid1 video input.
Vid1 ARC Off	Turns Off SD to SD aspect ratio conversion.
Vid1 ARC LTBX	Converts 16:9 anamorphic video to letterbox.
Vid1 ARC H CP	Converts 16:9 anamorphic video to 4:3 standard (H crop—crops left and right edges of video).
Vid1 ARC PLBX	Converts 4:3 standard video to 16:9 anamorphic (pillarbox).
Vid1 ARC V CP	Converts letterbox video to 16:9 anamorphic (V crop).
Vid1 ARC 14x9	Converts 16:9 anamorphic video to 14:9 cropped.
Vid1 DC Crop	Downconverts HD source to cropped 4x3 picture.
Vid1 DC ANA	Downconverts HD source to anamorphic picture.
Vid1 DC 14x9	Downconverts HD source to 14x9 picture.
Vid1 DC Auto AFD	Downconverts HD source automatically using the best mode for the input video Active Format Description (AFD) code.
Vid1 DC LTBX	Downconverts HD source to letterbox picture.
Vid1 UC 4x3 PB	Upconverts SD source to 4x3 pillarbox.
Vid1 UC 14x9 PB	Upconverts SD source to 14x9 pillarbox.
Vid1 UC FLSCR	Upconverts SD source to full screen.
Vid1 UC LB FUL	Upconverts SD source from letterbox to full.
Vid1 UC WDZM	Upconverts SD source to a wide zoom.
Vid2...	Repeat the above for Vid2 except that UC Wide Zoom is replaced by Vid2 UC CSTM, which Upconverts an SD source to a user-specified format.

3.1–4 GPI 1–4 OUT

The setting of this parameter determines whether certain FS2 events will generate a GPI trigger output at GPI outputs 1, 2, 3, or 4. The GPI interface pinout is presented in [“GPI Pinouts” on page 108](#).

No Action (<i>default</i>)	Does not trigger a GPI output regardless of event.
Alarm	Generates a GPI out trigger if an internal alarm condition occurs.
No Video 1	Generates a GPI out trigger if no video is detected at the input.
No Video 2	Generates a GPI out trigger if no video is detected at the input.
No Ref	Generates a GPI out trigger if no video is detected at the Ref input.

Interaction of Presets and GPIs

If you use a GPI input trigger to recall a preset, the recall changes the *GPI IN Response* setting to whatever *GPI IN Response* setting the preset contains. As the following examples explain, this feature offers both the power of serial recalls and the possibility of triggering a recall that changes *GPI IN Response* to something unintended.

Example of a Serial Recall The advantage of using *GPI IN Response* with presets is that you can trigger a series or even a looping series of preset recalls. For example, suppose *GPI IN 1 Response* in Preset 1 is set to Preset 2, and *GPI IN Response* in Preset 2 is set to Preset 1. Triggering the GPI will toggle between the two presets.

Example of an Unintended Recall Suppose you trigger *GPI IN 1* while the current *GPI IN 1 Response* parameter is set to Preset 1. This recalls Preset 1 as expected. However, suppose Preset 1 contains a stored *GPI IN 1 Response* setting of *No Action*. If you trigger GPI IN 1 later, expecting to recall Preset 1 again, the FS2 instead performs *No Action*. To prevent unexpected changes in the *GPI IN Response* parameters, set these parameters as desired before storing presets; in the example, set *GPI IN 1* to Preset 1 before you store Preset 1.

CONFIG Menu Group

The *CONFIG* Menu Group includes parameters for setting up the FS2's network, system name, SNMP, alarm, and screen saver configurations.

1 System Name

This parameter defines a unique name for the FS2. This same name is used both when displaying systems via the web interface and when displaying the FS2's screen saver.

Variable	Set the system name, up to 20 characters. <i>Default: aja-fs2</i>
----------	---

Name Entry Procedure Set the name as follows:

1. Push *ADJUST* momentarily to enter character editing mode.
2. Turn *SELECT* to advance the blinking cursor to each character.
3. Turn *ADJUST* to scroll through the choices for each character. These characters are allowed: A through Z (uppercase), a through z (lowercase), numerals, hyphen (-), period (.), and space (blank). Leave the desired character selected and advance to the next one.
4. Push *ADJUST* to save and activate the name after all characters are defined.
 - To abandon changes before saving, push *SELECT*.
 - To return to the default name at any time, hold down *ADJUST*.

NOTE: To eliminate trailing characters to shorten an existing system name, overwrite them with a hyphen (-) or space.

2.1 IP Config

This parameter determines the type of TCP/IP network configuration used by the FS2. Consult your network administrator about how to set this value.

DHCP (<i>default</i>)	Select automatic IP address assignment from the LAN DHCP server. If the FS2 cannot find a DHCP server, it fails over to the static IP address.
Static Addr	Assign a static IP address manually (using parameters 2.2, 2.3, and 2.4). The factory default static IP address: 192.168.0.2

2.2 IP Address

This parameter determines the static IP address used by the FS2 for TCP/IP networking. Consult your network administrator about how to set this value.

IP Address variable	If 2.1 is set to <i>DHCP</i> dynamic addressing (default), the IP Address is set automatically by the network's DHCP server. If 2.1 is set to <i>Static Addr</i> , manually enter an IP address. If 2.1 is set to <i>DHCP</i> and there is a DHCP failure, the IP address is set to the static IP address. The factory default static IP address is 192.168.0.2.
---------------------	--

Octet Value Entry Procedure

Set the octets (numbers between periods) values as follows:

1. Push *ADJUST* momentarily to enter edit mode.
2. Turn *SELECT* to select the octet you want to edit, indicated by blinking.
3. Turn *ADJUST* to enter the new value.
 - If you need to revert to the previous setting (undo changes), push *SELECT*.
4. Push *ADJUST* momentarily to save and activate the new setting.
 - If you want to revert to the default value, hold down *ADJUST* for 4 seconds.

2.3 Subnet Mask

This parameter determines the subnet mask used by the FS2 for TCP/IP networking. Consult your network administrator about how to set this value.

Subnet Mask variable	Enter a subnet mask compatible with your LAN. This is only needed for Static IP configurations. If 2.1 is set to DHCP, the Subnet Mask is set by the DHCP server and cannot be changed by the user. If 2.1 is set to <i>Default Addr</i> , the default <i>Subnet Mask</i> is 255.255.255.0
----------------------	--

2.4 Default Gateway

This parameter determines the gateway or router used on your LAN for TCP/IP networking. Consult your network administrator about how to set this value.

Without a properly configured default gateway (whether you have a router/gateway or not), the FS2 will be unable to see other FS2s on the network, although you may still be able to control this FS2 via a web browser. Also, without a proper gateway defined, the discovery feature "Available FS2s—Click to Refresh" on the *Network* web page will fail to list other FS2s on the network.

Gateway Address variable	Enter the address of the gateway or router used to connect the FS2 to the network. <i>Default:</i> 192.168.0.1
--------------------------	--

3 MAC Address (view only)

Selecting this parameter allows you to view the FS2 MAC address. The MAC address is a unique value associated with the FS2's internal network adapter. MAC addresses are also known as hardware addresses or physical addresses. MAC addresses uniquely identify an Ethernet adapter on a LAN.

MAC address format: MM:MM:MM:SS:SS:SS

The value is 12-digit hexadecimal, where the first half identifies the manufacturer and the second half identifies the unique serial number.

SNMP Menu Parameters

The following parameters are used to setup the FS2 SNMP (Small Network Management Protocol) feature.

- 4.0 SNMP Enable

- 4.1 SNMP Trap Destination 1
- 4.2 SNMP Trap Port 1
- 4.3 SNMP Trap Destination 2
- 4.4 SNMP Trap Port 2

In addition, the following parameters described below may affect SNMP messages:

- 5 Power Supply Alarm
- 6.1 Vid1 Format Alarm
- 6.2 Vid2 Format Alarm
- 7 Reference Alarm

Refer to "[Chapter 6: SNMP on page 101](#)" for a description of SNMP and how the FS2 supports it.

5 Power Supply Alarm

This parameter controls how the FS2 alarm responds to power supply disconnection or failure. If the FS2 will be connected using only one power cord and supply, you can suppress the alarm. Changes to this setting are automatically saved.

Normal (default)	Alarm triggers if either internal power supply experiences a failure or is disconnected from mains power.
Suppress	Alarm will not be triggered by a power supply failure or disconnection from power.

6.1 Vid1 Format Alarm

When set to *Normal* (default), an alarm is triggered whenever the selected input video signal format of Video Proc 1 is incompatible with the selected output format (refer to the matrix of inputs and compatibilities presented in *Chapter 2*). If you want the FS2 alarm to only trigger on hardware failures, you can suppress the *Format Alarm*. The front panel Vid 1 FMT ERR LED lights when format errors are detected even if this parameter is set to *Suppress*. Changes to this setting are automatically saved.

Normal (default)	Alarm triggers if the format of the selected input video signal is incompatible with the selected output format.
Suppress	Alarm will not be triggered by a format incompatibility.

6.2 Vid2 Format Alarm

This parameter operates the same as 6.1 Vid1 Format Alarm above, but applies to the input video signal format of Video Proc 2.

7 Reference Alarm

This parameter controls how the FS2 responds when one of the Video Processors has a format that is incompatible with the Reference video signal. When set to *NORMAL*, the alarm triggers if the Reference signal is not detected or is incompatible with the processor format. If you want the FS2 Reference alarm to trigger only on hardware failures, you can suppress the alarm. Changes to this setting are automatically saved.

Normal (default)	Alarm triggers if the reference signal is not detected or is incompatible with the processor format.
Suppress	Alarm will not be triggered by reference errors.

NOTE: For proper operation the Input reference signal must be stable and properly terminated using a 75-ohm terminator on either the unused loop connector or the last piece of downstream equipment to which the Ref Video is connected.

8 Hidden Menus

This parameter lets you choose whether to hide or show inactive menus.

Hide Inactive (<i>default</i>) Show All	Hides menus that are not in use. Shows all menus, even those that are not in use.
--	--

9 Screen Saver

This parameter lets you choose the menu screen saver.

On (AJA Logo) (<i>default</i>) Off System Name	AJA logo screen saver is displayed Screen saver is turned off. Screen saver displays the system name.
--	---

10 Display Intensity

This parameter determines the brightness of the alphanumeric display and front panel LEDs.

Variable	Dim or brighten the alphanumeric display and activity indicator LEDs in steps from 1 (dim) to 8 (brightest).Default: 6
----------	--

11 Fan Speed

This parameter determines the speed (and sound level) of the FS2's internal cooling fans. To prevent system damage, this setting may be overridden temporarily, and the fan can be set to a higher speed if the system detects very high internal temperatures. Changes to this setting are automatically saved

Variable	Changes the fan speed in steps from 1 (slow) to 10 (fast). Default is 10.
----------	--

12 Serial Number

This parameter displays the FS2's unique serial number.

13 Software Version

This parameter displays the FS2's software version number.

14 Reboot

This parameter lets you reboot the FS2. Press and hold in both front panel knobs simultaneously to reboot.

During reboot, the display shows *[Rebooting]*, goes dark momentarily, and then shows the percentage of progress as the system reboots. Rebooting takes a couple of minutes.

PRESET Menu Group

The *PRESET* Menu Group provides the means of saving, editing the names of, and loading FS2 presets. A preset is a set of all System, Video 1/2, Audio 1/2, and Output parameters as they were set at the time the preset was stored.

	Caution! When you recall a Preset Configuration, the recalled preset immediately replaces the system's existing configuration. All previous settings are lost unless you have previously stored them in another preset configuration or an exported file.
---	---

During recall, the display reads, *Recalling* until the recall is finished. On recall completion, the displays shows the success or failure: *Recalled*, *Failed*, or *Empty*. A failed or empty recall does not recall anything and leaves the FS2 as it was. (Preset registers are empty until you store something in them.)

During a store, the display reads *Storing* until the store is finished. On store completion, the display shows *Complete* or *Failed*. A failed store does not store anything and leaves the preset register as it was. To retry a failed store, turn *SELECT* to another preset number and then back to the desired preset number.

1 Factory Preset

This parameter recalls a read-only Factory Preset.

Factory Recall	Recalls factory values. Push <i>ADJUST</i> momentarily to perform (take) the recall. The display reports "Loading" and "Complete" during the recall. User preferences, network settings, and existing Presets are not affected by recalling the Factory Preset.
----------------	---

1.1-1.40 Presets #1-#40

These parameters let you recall, edit the name of, and store an FS2 preset configuration for the selected storage register. Forty storage registers are available.

Preset #1-#40	Shows the currently selected preset register number. Turn <i>SELECT</i> choose the desired register. Then turn <i>ADJUST</i> to choose Recall, Edit Name, or Store for the selected register.
[Preset Name]	Shows the name of the selected preset register, which can be edited.
Recall	Recalls that preset. Push <i>ADJUST</i> momentarily to perform (take) the recall. The display reports "Loading" and "Complete" during the recall.
Edit Name	Enables editing the name of the preset register. Push <i>ADJUST</i> to enable editing (blinking character), use the <i>SELECT</i> and <i>ADJUST</i> knobs to edit the name and then press <i>ADJUST</i> to save the edited preset register name.
Store	Stores the current set of all System, Video 1/2, Audio 1/2, and Output parameters to the selected preset register.

Interaction of Presets and GPIs

Triggering presets using GPI inputs offers considerable power but also requires some care to avoid unexpected results. If you plan to trigger presets using GPIs, please see the information about the ["Interaction of Presets and GPIs" on page 48](#).

SYSTEM Menu Group

The *SYSTEM* Menu Group includes parameters for setting up various FS2 system related features (video formats, audio level standards, etc).

1 Component In Format

This parameter configures the format of the *Component* video input for SMPTE, Beta, or Composite. Selecting *Composite (Y)* programs the *Component (Y/G)* input to accept a composite signal. In this case, all parameters set to a value of *Component* are subject to

and influenced by the composite signal on the *Component Y/G* input. For example, in the *VIDEO* menu, setting *Video1 Input* to the value of *Component*, switches the composite signal on the *Component Y/G* input into the Video 1 Processor.

SMPTE YPbPr (default)	Configure the Component Video Input source as SMPTE YPbPr. This is the default for HD component video.
Beta YPbPr	Configure the Component Video Input source as Beta YPbPr (standard definition).
Composite (Y)	Configure the Component Video Input source as composite, providing a second composite input (requires version 1.1 firmware).

2 Component Out Format

This parameter configures the format of the *Component* video output for SMPTE, Beta, RGB, or Composite. Selecting *Composite (Y)* programs the *Component (Y/G)* output to deliver a composite signal. In this case, all parameters set to a value of *Component* are subject to and influenced by the composite signal on the *Y/G Component* output. For example, in the *OUTPUT* menu, *Component Out*, selecting *Processor2* will switch the composite signal from Video Processor 2 to the *Component Y/G* connector.

SMPTE YPbPr (default)	Configure the Component Video Output as SMPTE YPbPr. This is the default for HD component video.
Beta YPbPr	Configure the Component Video Output as Beta YPbPr (SD).
RGB	Configure the Component Video Output as RGB.
Composite (Y)	Configure the Component Video Output source as composite, providing a second composite output (requires version 1.1 firmware).

3 Analog Audio Std

This parameter sets the *Analog Audio Input* and *Output* levels of the FS2 with reference to full scale digital (0 dBFS). Selections range from consumer levels (+12 dBu) to SMPTE professional (+24 dBu).

+24 dBu (default)	Select +24 dBu as the expected analog audio level.
+18 dBu	Select +18 dBu as the expected analog audio level.
+15 dBu	Select +15 dBu as the expected analog audio level.
+12 dBu	Select +12 dBu as the expected analog audio level. (Above settings correspond to maximum amplitude–0 dBFS)

NOTE: See Chapter 3 *FS2 Audio Level Choices—Pro or Consumer regarding audio levels.*

4 SDI1 3G Detect

This parameter configures 3G operation of the SDI 1 video input.

Auto Detect (default)	Automatically detects presence of 1080p50/60 or Dual Stream video.
1080p50/60	Configures the SDI1 input for 1080p50/60 (single) video.
Dual Stream	Configures SDI 1 for Dual Stream 3G video (uses SDI 1 and SDI 2 in Input Crosspoint matrix).

In *Auto Detect* mode, the hardware looks for SMPTE 352 Payload ID ANC data on the video inputs to determine whether there are two independent 1080i signals (Dual Stream) or a single 1080p50/60 signal. If there is no SMPTE 352 data, the default is to assume *1080p50/60* (single), but you can manually instruct the FS2 to always assume either *1080p50/60* or *Dual Stream* by selecting one of those choices.

In *1080p50/60* mode, the system always assumes that the input is a single 1080p50/60 signal (even if there is SMPTE 352 data to the contrary).

In *Dual Stream* mode, the system always assumes (even if there is SMPTE 352 data to the contrary) that the input consists of two multiplexed independent 3G video streams. The signals are demuxed as shown.

Figure 9. Dual Stream 3G Mode Schematic

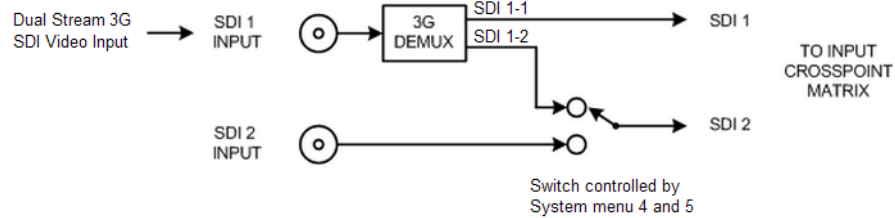

5 SDI2 Input Protect

This parameter allows you to protect Input SDI 2 from being taken by a *Dual Stream* selection made with parameter 4 above.

Normal (default) Dual Stream	SDI2 cannot be used by Dual Stream 3G SDI video on SDI Input 1. Allows SDI2 to be used by a Dual Stream 3G SDI input present on SDI 1.
---------------------------------	--

In the *Normal* setting (default), the SDI 2 video signal always comes from the SDI 2 physical input. Choosing *Auto Detect* or *Dual Stream* in parameter 4 does not switch away from the physical input.

In the *Dual Stream* setting, the FS2 assumes both channels of Dual Stream 3G video are muxed onto a single wire at the SDI1 input. The SDI 2 video signal is then taken internally from the SDI 1 Stream 2 signal instead of the SDI2 In connector.

The following table shows the selections and their results. In the table, SDI1-1 and SDI1-2 are the two muxed streams entering the SDI1 Input.

4 SDI-3G Detect Setting	5 SDI2 Input Protect Setting	1 Video Input Setting	Resulting Input to Crosspoint Matrix
Dual Video	Dual Stream	SDI1	SDI1-1
		SDI2 (unused)	SDI1-2
	Normal	SDI1	SDI1-1
		SDI2	SDI2
Single Video	Dual Stream	SDI1	SDI1
		SDI2	SDI2
	Normal	SDI1	SDI1
		SDI2	SDI2

6 Fiber1 3G Detect

This parameter configures 3G operation of the Fiber 1 video input. The input can be set for *1080p50/60* (single video), *Dual Stream 3G SDI* (two muxed videos), or *Auto-Detect* whether the input is 1080p50/60 single or Dual Stream 3G video (requires SMPTE Format ID to be present in the SDI Input). See parameter *4 SDI 1 3G Detect* for an illustration and details.

Auto Detect (default)	Automatically detects presence of 1080p50/60 or muxed video.
1080p50/60	Configures the Fiber 1 input for 1080p50/60 video.
Dual Stream 3G	Configures Fiber 1 for Dual Stream 3G Video (uses SDI1 and SDI2 in Input Crosspoint matrix).

7 Fiber2 Input Protect

This parameter allows you to protect Input Fiber 2 from being taken by a *Dual Stream* selection made in *6 Fiber1 3G Format Detect* setting.

Normal (default)	Fiber 2 cannot be used by Dual Stream 3G SDI video present on Fiber 1.
Dual Stream	Allows Fiber 2 to be used by a Dual Stream 3G SDI input present on Fiber 1.

In the *Normal* setting (default), the Fiber 2 video signal always comes from the SDI 2 physical input. Choosing *Dual Stream* video in parameter 6 does not switch away from the physical input.

In the *Dual Stream* setting, the FS2 assumes both channels of Dual Stream 3G video are muxed onto a single wire at the Fiber 1 input. The Fiber 2 video signal is then taken internally from the Fiber 1 Channel 2 signal instead of the Fiber 2 Input connector.

8 Genlock Source

This parameter selects the source of reference video used to genlock to, either automatically or explicitly.

Reference (default)	Use the signal on the <i>Ref</i> connector as the genlock source.
Vid1 Input	Use the <i>Vid1</i> input signal as the genlock source.
Vid2 Input	Use the <i>Vid1</i> input signal as the genlock source.
Free run	Free run mode (FS2 syncs to its own timebase, not locked to an external source).

NOTE: *HDMI can be used as a reference (with SYSTEM 8 Genlock Source set to Vid1 Input or Vid2 Input), but HDMI is not a valid reference source when the signal on the HDMI input originates from a VESA-format computer DVI signal.*

9 Frame Rates

This parameter selects the HD video frame rate associated with the video standard.

59.94/23.98 (default)	Select <i>59.94/23.98</i> if your desired rate is either 59.94 or 23.98.
50/25	Select <i>50/25</i> if your desired rate is either 50 or 25 (PAL).
60/24	Select <i>60/24</i> if your desired rate is either 60 or 24.

NOTE: *Changing the Frame Rates selection automatically selects a new value for 2 Output Format. Each Frame Rates selection remembers its own Output Format settings.*

10 NTSC Standard

This parameter selects the NTSC video standard. This setting only applies when parameter *9 Frame Rate* is "59.97/23.98".

NTSC (default)	Select NTSC for North America.
NTSC Japan	Select NTSC for Japan.
PAL M	Select PAL-M for Brazil.

The NTSC standard applies to both the Output video standard, and the expected Input video standard. The FS2 does not convert NTSC to PAL-M, or vice-versa.

11 Composite Downconv

This parameter selects the type of Downconversion performed on the incoming selected HD source input for the analog *Composite* (NTSC or PAL) video output.

Crop (default)	Image is cropped to fit new screen size.
Anamorphic	HD image is converted to full-screen SD with a 16x9 aspect ratio (anamorphic).
14x9	Image is reduced slightly with aspect ratio preserved. Black is added top and bottom, and the left and right sides are cropped.
Auto AFD	Automatically selects the best Downconvert mode based on the input video's Active Format Description (AFD) code. If the input video is not carrying an AFD VANC code, the Downconverter defaults to the mode specified in parameter menu <i>16.3 Downconvert AFD Default</i> .
Letterbox	Image is reduced with black top and bottom added to image area, with the aspect ratio preserved.

This parameter is used only when the Video Processor feeding the Composite output (Output parameter *5 Composite Out*) is producing HD. If that Video Processor is producing SD, the Composite Downconverter is not needed, and the format on the Composite output is the same as seen on the other outputs (controlled by parameter *7 Downconvert Mode* for that Video Processor).

NOTE: *Using the Downconverter adds a frame of video delay and causes the analog Composite output to be one frame behind the other outputs.*

12 HDMI RGB Range

This parameter selects the output range for HDMI YCbCr. *Full* allows a range of 0-255 and *SMPTE* limits the range to 16 to 235 (see note for details).

Note: YCbCr luminance (Y) channel data ranges nominally between 16 (black) and 235 (white). Values outside of this range are typically clamped to the valid range. This may cause confusion because JPEG JFIF YCbCr values range between 0 and 255. Mixing these values causes video contrast shifts. You can avoid these shifts if you maintain one range of values throughout your system.

Full (default)	Selects an HDMI luminance output range of 0-255.
SMPTE	Selects an HDMI luminance output range of 16-235.

14.0 AES/EBU SRC Mode

This parameter controls the mode of the audio sample rate converters for AES/EBU input audio pairs.

In *Manual* mode, the sample rate converters are enabled manually for each AES pair using parameters 14.1 through 14.8.

In *Auto* mode, the system decides how to handle sample rate conversion. Normal PCM audio passes through the Sample Rate Converters and gets converted, as appropriate. AES channels in which the *non-audio* flag is set in the Channel Status Word are automatically detected and allowed to bypass the Sample Rate Converters; the signal passes unaltered and the existing data is preserved.

Auto (default)	The signal bypasses the Sample Rate Converters for audio channels containing a non-audio flag in the Channel Status Word. If the non-audio flag is not set, the signal passes normally through the Sample Rate Converters.
Manual	The FS2 determines what to do about audio sample rate conversion on a channel pair-by-pair basis, determined by settings 14.1-14.8. If a channel pair is set to On, sample rate conversion is applied to that channel pair. If a channel pair is set to Bypass, the FS2 leaves embedded audio as is, bypassing sample rate conversion; this is useful for Dolby® 5.1 embedded audio and other applications where you do not want sample rate conversion to occur.

14.1–14.8 AES/EBU SRC

This group of parameters controls audio sample rate conversion on AES/EBU input audio channel pairs 1/2, 3/4, 5/6, 7/8, 9/10, 11/12, 13/14, and 15/16.

When 14.0 AES/EBU SRC Mode is set to *Auto*, no settings per channel are required; sample rate conversion occurs normally for all channels unless the *non-audio* flag is set in the Channel Status Word, in which case sample rate conversion gets bypassed and the signal is passed through unaltered.

When 14.0 AES/EBU SRC Mode is set to *Manual*, each channel pair can be set manually to *On* or *Bypass*, using parameters 14.1–14.8.

On is the default setting in which audio is rate-converted and synced with video (SRC is applied).

Bypass is available for use when Dolby® 5.1 and similar schemes need to be preserved and the audio data passed unaltered (no SRC is applied).

Set these parameters to *Manual* (14.0) and *Bypass* (14.1-14.8) only if BOTH the following items are true:

- You want to pass unaltered digital encoded audio from either an embedded or AES Input to an embedded and/or AES Output.
- You have the embedded or AES input genlocked to the FS2 output. In other words, the encoded audio will not survive the frame-sync function (dropping or repeating frames) so it needs to be set to lock to the input. You can lock to a reference only if that reference is driving both the FS2 and the upstream source of the embedded or AES input to the FS2.

On (default)	Audio sample rate conversion (SRC) is applied to the affected channel pairs and keeps the video and audio synchronized.
Bypass	Audio sample rate conversion (SRC) is NOT applied to the affected channel pairs. The signal is passed through unaltered, which is useful for preserving Dolby® 5.1 embedded audio and other applications where existing data on the input must be preserved and passed to the output.

15 Dolby Decoder Input

This menu selects the audio input pair used to feed compressed data to the Dolby Audio Decoder (option).

Input Pair	AES Ch1/2	SDI 1 Ch1/2	Fiber 1 Ch1/2
	AES Ch3/4	SDI 1 Ch3/4	Fiber 1 Ch3/4
	AES Ch5/6	SDI 1 Ch5/6	Fiber 1 Ch5/6
	AES Ch7/8	SDI 1 Ch7/8	Fiber 1 Ch7/8
	AES Ch9/10	SDI 1 Ch9/10	Fiber 1 Ch9/10
	AES Ch11/12	SDI 1 Ch11/12	Fiber 1 Ch11/12
	AES Ch13/14	SDI 1 Ch13/14	Fiber 1 Ch13/14
	AES Ch15/16	SDI 1 Ch15/16	Fiber 1 Ch15/16
		SDI 2 Ch1/2	Fiber 2 Ch1/2
		SDI 2 Ch3/4	Fiber 2 Ch3/4
		SDI 2 Ch5/6	Fiber 2 Ch5/6
		SDI 2 Ch7/8	Fiber 2 Ch7/8
		SDI 2 Ch9/10	Fiber 2 Ch9/10
		SDI 2 Ch11/12	Fiber 2 Ch11/12
		SDI 2 Ch13/14	Fiber 2 Ch13/14
		SDI 2 Ch15/16	Fiber 2 Ch15/16

16 Dolby Decoder Mode

This parameter determines the Dolby Decoder “Bitstream Detect Mode” on the Dolby Decoder Card. In Auto mode, the Dolby Decoder decodes Dolby E, Dolby Digital, or Dolby DigitalPlus bitstreams. If none of the above are detected, the card passes the incoming audio as PCM.

In Dolby E mode, the Dolby Decoder only decodes Dolby E bitstreams, and mutes its outputs if it detects anything else.

In Dolby D mode, the Dolby Decoder only decodes Dolby Digital or Dolby DigitalPlus bitstreams, and mutes its outputs if it detects anything else.

Auto (default)	Automatically decode Dolby E, Dolby digital, Dolby DigitalPlus, or PCM.
Dolby E	Decode Dolby E only.
Dolby D	Decode Dolby Digital or Dolby DigitalPlus only.

17 Dolby Decoder Aux Out

The Dolby Decoder outputs eight channels of decoded audio, plus an additional Aux output which is a 2-channel (stereo) mixdown of one of the selected Dolby Programs (1-8). This parameter determines which of the Programs is used for the Aux mixdown.

In this context, *Program* is not the same as a physical input channel. To Dolby, a Program is a related set of audio channels. For example, a 5.1 audio source requires 6 channels and is considered one Program. Consequently, there may be a varying number of Programs available on a given Dolby E bitstream. It is possible to have up to eight Programs on a single bitstream if eight discrete mono channels were encoded.

Program 1 (default)	Set the Dolby Aux Output to a mixdown of Program 1
Program 2	Set the Dolby Aux Output to a mixdown of Program 2
Program 3	Set the Dolby Aux Output to a mixdown of Program 3
Program 4	Set the Dolby Aux Output to a mixdown of Program 4
Program 5	Set the Dolby Aux Output to a mixdown of Program 5
Program 6	Set the Dolby Aux Output to a mixdown of Program 6
Program 7	Set the Dolby Aux Output to a mixdown of Program 7
Program 8	Set the Dolby Aux Output to a mixdown of Program 8

18 Dolby Decoder Aux Mode

The Dolby Decoder outputs eight channels of decoded audio, plus an additional Aux output which is a 2-channel (stereo) mixdown of one of the selected Dolby Programs. This parameter determines how the Aux mixdown is produced. Lt/Rt produces a stereo mixdown which takes rear surround channels into account (when available).

Selecting *Lo/Ro* produces a stereo mixdown using only the front channels, *Mono* produces a mono mixdown, and *Mute* produces full quality, high fidelity silence.

Lt/Rt	Produces an Aux stereo mixdown including the rear surround channels.
Lo/Ro	Produces an Aux stereo mixdown using only the front channels.
Mono	Produces an Aux mono mixdown.
Mute	Produces full quality high fidelity silence.

OUTPUT Menu Group

This menu group selects the video and audio outputs that are routed to the rear panel connectors.

1.1 SDI1 Video Out

This parameter selects which video processor output is sent out the *SDI 1* output.

Processor1 (default)	Sends the output of Processor 1 to the SDI1 output.
Processor2	Sends the output of Processor 2 to the SDI1 output.
Proc1+Proc2	Sends multiplexed Proc1 & 2 to the SDI1 output (Dual Stream 3G).

The default is to send the output of Processor 1 to SDI1 Out.

The *Proc1+Proc2* selection multiplexes two separate 1.5 Gb HD video signals from both video processor outputs into a Dual Stream 3G SDI (muxed) output as illustrated below. This selection will only make valid video if both video processors are set to output the same HD video format and that format is not 1080p50/60.

Figure 10. Dual Stream 3G Output

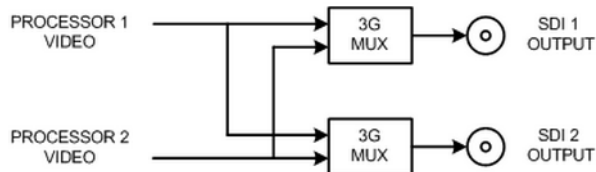

1.2 SDI2 Video Out

This parameter selects which video processor output is sent to the *SDI2* output, and is similar to “1.1 SDI1 Video Out” on page 60. The default is to send the output of Processor2 to SDI2 Out.

Processor1	Sends the output of Processor 1 to the SDI2 output.
Processor2 (default)	Sends the output of Processor 2 to the SDI2 output.
Proc1+Proc2	Sends multiplexed Proc 1 & 2 to the SDI2 output (Dual Stream 3G).

2.1 Fiber1 Video Out

This parameter selects which video processor output is sent to the optional *Fiber1* output, and is similar to “1.1 SDI1 Video Out” on page 60. The default is to send the output of Processor 1 to Fiber1 Out.

Processor1 (default)	Sends the output of Processor 1 to the Fiber1 output.
Processor2	Sends the output of Processor 2 to the Fiber1 output.
Proc1+Proc2	Sends multiplexed Proc 1 & 2 to the Fiber1 output (Dual Stream 3G).

2.2 Fiber2 Video Out

This parameter selects which video processor output is sent to the optional *Fiber2* output, and is similar to “1.1 SDI1 Video Out” on page 60. The default is to send the output of Processor 2 to the Fiber2 Output.

Processor1	Sends the output of Processor 1 to the Fiber2 output.
Processor2 (default)	Sends the output of Processor 2 to the Fiber2 output.
Proc1+Proc2	Sends multiplexed Proc 1 & 2 to the Fiber2 output (Dual Stream 3G).

3 HDMI Video Out

This parameter selects which video processor output is sent to the *HDMI* output.

Processor1 (default)	Sends the output of Processor 1 to the HDMI output.
Processor2	Sends the output of Processor 2 to the HDMI output.

4 Component Out

This parameter selects the video processor output to be sent out the *Component* analog output.

Processor1 (default)	Sends the output of Processor 1 to the Component output.
Processor2	Sends the output of Processor 2 to the Component output.

5 Composite Out

This parameter selects the video processor output to be sent out the *Composite* analog output. If an HD output is sent to the Composite Output, a separate Downconverter dedicated to the Composite Output will provide an SD output.

Processor1 (default)	Sends the output of Processor 1 to the Composite output.
Processor2	Sends the output of Processor 2 to the Composite output.

6 HDMI Audio Out

This parameter selects which audio processor output channels (1–8 or 9–16) are embedded in the *HDMI* output. The Audio Processor associated with the selected Video Processor for the HDMI output is used as the audio source (Video Proc 1 = Audio Proc 1, Video Proc 2 = Audio Proc 2); this parameter selects which channels of that source are embedded.

Channels 1-8 (default)	Selects audio channels 1-8 to embed in the HDMI output.
Channels 9-16	Selects audio channels 9-16 to embed in the HDMI output.

7 AES/EBU Audio Out

This parameter selects the audio processor output to be sent out the *AES/EBU* digital audio output.

Processor1 (default)	Selects Audio Processor 1 output to send to the AES/EBU output.
Processor2	Selects Audio Processor 2 output to send to the AES/EBU output.

8 Analog Audio Out This parameter selects which group of channels (1–8 or 9–16) from which audio processor output (1 or 2) will be sent to the *Analog Audio* output.

Audio1 Ch1-8 (default)	Sends Audio Proc1 output Ch1-8 to the Analog Audio output.
Audio1 Ch9-16	Sends Audio Proc1 output Ch9-16 to the Analog Audio output.
Audio2 Ch1-8	Sends Audio Proc2 output Ch1-8 to the Analog Audio output.
Audio2 Ch9-16	Sends Audio Proc2 output Ch9-16 to the Analog Audio output.

9.1 SDI1 3G Config The *SDI13G Config* parameter determines how 1080p50/60 signals are formatted for the SDI 1 output. The first two choices select either “Level A” or “Level B” as described in the SMPTE 425 standard. The third selection ties SDI 1 Out and SDI 2 Out together into a single 1.5 Gb Dual-link 1080p50/60 output. In this case, the SDI2 Video Out and SDI2 Audio Out selections are ignored.

3 Gb-Level A (default)	Formats 3G SDI Output as Level A.
3 Gb Level-B	Formats 3G SDI Output as Level B.
1.5 Gb Dual Link	Formats SDI 1 and SDI 2 as 1.5Gb “Dual Link.”

9.2 SDI2 3G Config The *SDI2 3G Config* parameter determines how 1080p50/60 signals are formatted for the SDI 2 output. The two choices select either “Level A” or “Level B” as described in the SMPTE 425 standard. (If the SDI1 selection is *Dual Link*, these SDI2 settings are ignored because the SDI 2 output is used for dual link.)

3 Gb-Level A (default)	Formats 3G SDI Output as Level A.
3 Gb-Level B	Formats 3G SDI Output as Level B.

10.1 Fiber1 3G Config The *Fiber1 3G Config* parameter determines how 1080p50/60 signals are formatted for the Fiber 1 output. The first two choices select either “Level A” or “Level B” as described in the SMPTE 425 standard. The third selection ties Fiber 1 Out and Fiber 2 Out together into a single 1.5 Gb Dual-link 1080p50/60 output. In this case, the Fiber2 Video Out and Fiber2 Audio Out selections are ignored.

3 Gb-A (default)	Sends 3 Gb format A 1080p 50/60 to the Fiber1 output.
3 Gb-B	Sends 3 Gb format B 1080p 50/60 to the Fiber1 output.
1.5 Gb Dual Link	Sends dual-link 1.5 Gb 1080p 50/60 to the Fiber1 and Fiber2 outputs. As the term “dual-link” implies, the signals and outputs are tied together.

10.2 Fiber2 3G Config The *Fiber2 3G Config* parameter determines how 1080p50/60 signals are formatted for the Fiber 2 output. The two choices select either “Level A” or “Level B” as described in the SMPTE 425 standard. (If the Fiber1 selection is *Dual Link*, these Fiber2 settings are ignored because the Fiber 2 output is used for dual link.)

3 Gb-Level A (default)	Formats 3G SDI Output as Level A.
3 Gb-Level B	Formats 3G SDI Output as Level B.

VIDEO 1 and VIDEO 2 Menu Groups

The following descriptions explain the Video 1 and 2 Menu Groups. Because the selections for the video processors are identical, both are described here.

Video Input and Output

This parameter performs input video source selection for the selected Video Processor (1 or 2). Multiple input sources are available at the connectors on the FS2 rear panel, but the active input source routed to the selected Video Processor is the one you select here.

1 Video Input

SDI1 (<i>default</i>)	Select SDI1 as the input source.
SDI2	Select SDI2 as the input source.
SDI DualLink	Select SDI DualLink, linking both SDI inputs as the input source.
Fiber1	Select Fiber1 as the input source.
Fiber2	Select Fiber2 as the input source.
Fiber DualLink	Select Fiber DualLink, linking both Fiber inputs as the input sources.
HDMI	Select the HDMI input as the input source.
Composite	Select Composite as the input source.
Component	Select Component as the input source.

Source Memory Changing the Video Input selection automatically selects new values for Proc Amp parameters (11.1 through 11.4) and Color Corrector (RGB) parameters (12.0 through 12.9). Each video source remembers its own Proc Amp and Color Corrector settings. This is referred to as Source Memory.

Audio Source Memory If AUDIO 3 Audio Follow Video is set to On, changing the Video Input selection will also automatically select new values for all audio parameters associated with Audio Follow Video (see the list provided in the description of parameter AUDIO 3 Audio Follow Video). Audio Source Memory is enabled only when AUDIO 3 Audio Follow Video is set to On.

Dual Link Dual Link referred to here is 1080p50/59.94 on two 1.5 Gb HD-SDI connections. Selecting Dual Link as the Video Input for Video Processor 1 or 2 will allocate both SDI Inputs for Dual Link use. Both Processors can use the Dual Link Input, or if only one Processor is using it, the other Processor is free to select another input. The Fiber inputs operate the same way.

2 Output Format This parameter defines the output format of the Video Processor (1 or 2). Available choices depend on the frame rate selection. The frame rate is set by the *Frame Rates* parameter (*System* menu 9).

Follow INPUT (<i>default</i>)	Follow the format of the selected input.
Follow REF	Follow the format of the reference input (Ref).
525/625<frame rate>	Select 525/625 SD as the Video Processor output.
720p<frame rate>	Select 720p HD as the Video Processor output.
1080i<frame rate>	Select 1080i HD as the Video Processor output.
1080PsF<frame rate>	Select 1080PsF HD as the Video Processor output.
1080p<frame rate>	Select 1080p HD as the Video Processor output.
2K1080p<frame rate>	Select 2K1080p HD as the Video Processor output.

Output Format Selection Constraint Available frame rates depend on System 9 Frame Rates parameter setting.

Output Follow Ref Exception If the parameter 2 Output Format is set to Follow Ref, and the 8 Genlock Source is set to Input, and the 1 Video Input is set to select one of the analog inputs, the output format will follow the input format rather than the format of the signal on the Ref BNC as might be expected. (This combination of settings effectively disconnects the Ref BNC.)

Output Timing Memory Changing the Output Format selection automatically selects new values for H & V timing parameters (14.1 Output Timing H, 14.2 Output Timing V and 14.3 Analog Output Fine). Each Output Format mode remembers its own H and V timing settings.

Output Format Mapping The Output Format selection is remembered for each of the frame rates. If you change the frame rate selection, the Output Format associated with the newly selected frame rate is recalled.

2K1080p Audio The FS2 does not support embedded audio output for the following formats:

- 2K1080p 29.97 or 2K1080p 30
- 2K1080p 59.94 or 2K1080p 60 when 3G Config is set to 3 Gb Level B or 1.5 Gb DualLink.

3 Video Output Mode The parameter sets the final video output of the Video Processor to normal video or the test pattern generator. Alarms occur if conflicting video formats are selected.

Normal (default) Test Pattern	Normal video output from the processors. The output of the test pattern generator.
----------------------------------	---

Background Fill

This parameter selects the background source used to fill any part of the processor output raster not filled with video from the main input video. For the Video Processor 1 menu, the second selection is *Video 2*. For the Video Processor 2 menu, the second selection is *Video 1*. Using this feature, you can key *Video 2* into *Video 1* or vice versa

4 Background Fill

Black (default) Video 1/2 Matte	Selects black as the background fill video. Selects Vid1 or Vid2 as the background fill video. Selects matte as the background fill video.
---------------------------------------	--

Loss of Input

This parameter selects the automatic action that occurs if the video input is lost. The *Black* selection (default) cuts the video to black. The *Freeze* selection freezes video on the last available good frame.

5 Loss of Input

Black (default) Freeze	Switches to black if input video is lost. Freezes on the last available good video frame if input is lost.
---------------------------	---

Upconvert and Downconvert

These parameter select the type of Upconversion the Video Processor performs on the selected SD source input. They are in effect only when the input is SD (525i or 625i) and the selected output format is HD (720p, 1080i, or 1080p), or when the input is HD (720p, 1080i, or 1080p) and the output is 2K (2048 x 1080). When upconverting to 2K, the selections do not precisely describe the resulting picture. For example, 4x3 pillar is not precisely 4x3, and 14x9 is not precisely 14x9. However, picture scaling is such that the visual effect closely resembles an SD-to-HD upconvert.

6 Upconvert Mode

4x3 Pillar 14x9 Pillar (default) Full Screen LB to Full Wide Zoom	Results in 4x3 image at center screen with black sidebars. Results in 14x9 image, zoomed slightly to fill a 14x9 image with black sidebars. Anamorphic full screen display. Image is zoomed to fit the full screen (letterbox). Using a combination of zoom and stretch, the image is sized to fit a 16x9 screen (this can introduce a small aspect ratio change).
---	--

Upconvert Illustrations

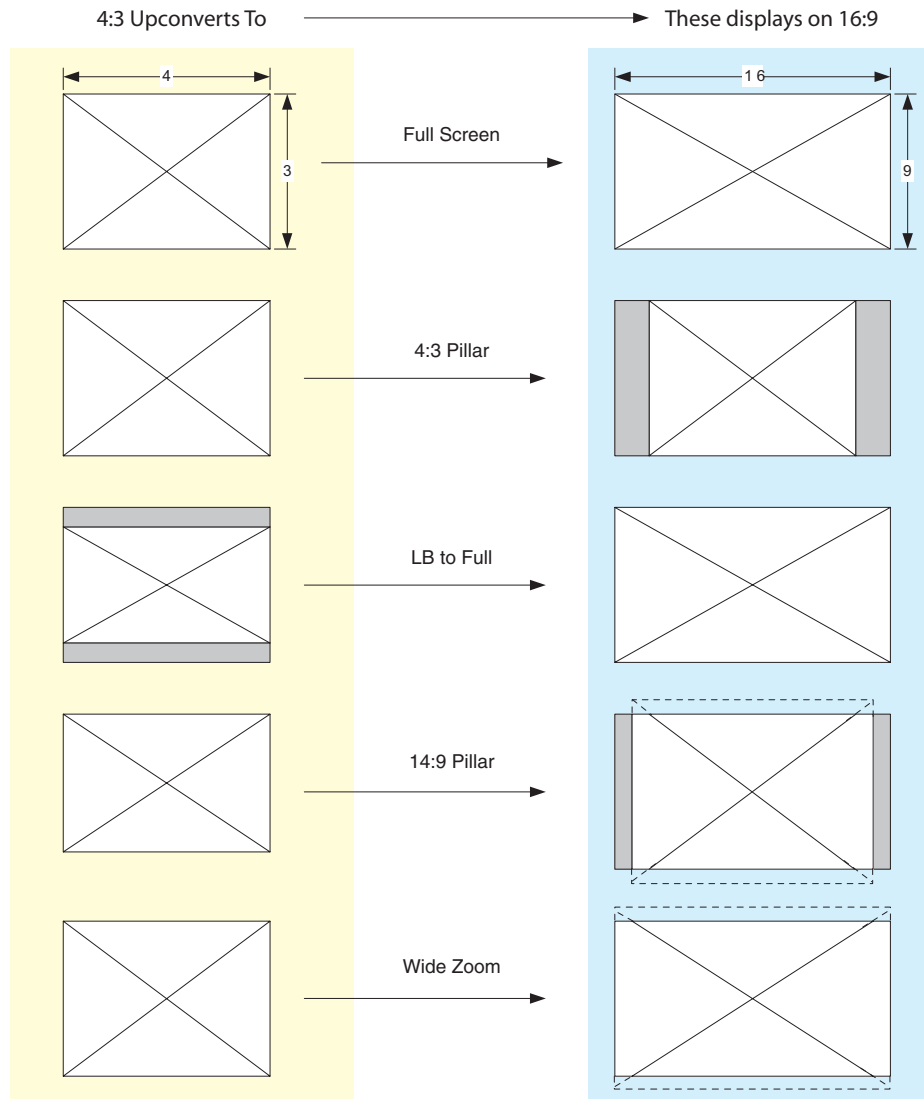

7 Downconvert Mode This parameter selects the type of Downconversion performed by the Video Processor on the selected HD source input. See the following Downconvert Illustrations for Downconversion examples. This parameter is in effect only when the input is HD (720p, 1080i, or 1080p) and the output format is SD (525i or 625i), or when the input is 2K (2048 x 1080) and the output is HD (720p, 1080i, or 1080p). When downconverting from 2K, the

selections do not precisely describe the resulting picture. For example, 14x9 is not precisely 14x9. However, picture scaling is such that the visual effect closely resembles an HD-to-SD downconvert.

Crop (<i>default</i>)	Image is cropped to fit new screen size.
Anamorphic	HD image is converted to full-screen SD with a 16x9 aspect ratio (anamorphic).
14:9	Image is reduced slightly with aspect ratio preserved. Black is added top and bottom, and the left and right sides are cropped.
Auto AFD	Automatically selects the best Downconvert mode based on the input video's Active Format Description (AFD) code. If the input video is not carrying an AFD VANC code, the Downconverter defaults to the mode specified in parameter menu 16.3 <i>Downconvert AFD Default</i> .
Letterbox	Image is reduced with black top and bottom added to image area, with the aspect ratio preserved.

Active Format Description (AFD) codes are carried in the vertical ancillary (VANC) portion of HD SDI video signals, specified in SMPTE 2016 as follows: "AFD information is intended to guide DTV receivers and/or intermediate professional video equipment regarding the display of video of one aspect ratio on a display of another aspect ratio."

In the FS2 Downconverter, the AFD code on the video input can be used to guide the Downconverter in choosing which mode to use to best display the important content of the input 16:9 HD video on the 4:3 SD output. For example, if the input AFD code is 10 (Full Frame), it means that the input video has important picture information throughout the full 16:9 frame, so the Downconverter should use Letterbox mode to be sure none of the content is cropped off. An AFD code of 9 (Pillarbox) says that the input video only has content within the center 4:3 area of the picture (usually because it originally came from an Upconverted SD signal) so the Downconverter Crop mode would be the best choice. There are 16 possible HD AFD codes, of which 8 are in common use. The FS2 does not process or use SD AFD codes.

FS2 AFD processing (passing, removing, and re-inserting) occurs based on the setting of parameters 7, 5.4, 16.1, and 16.2.

Auto AFD mode fully defines the size, position, and aspect ratio of the output raster. Thus, when in *Auto AFD* mode (Output Format set to an SD format, with an HD video input, and *Downconvert Mode* set to *Auto AFD*), any *Custom Size/Pos* settings are ignored, and those menus (13.0 - 13.8) are hidden. Likewise, when in *Auto AFD* mode, any *Region Of Interest* settings are ignored, and those menus (14.0 - 14.4) are hidden.

Downconvert Illustrations

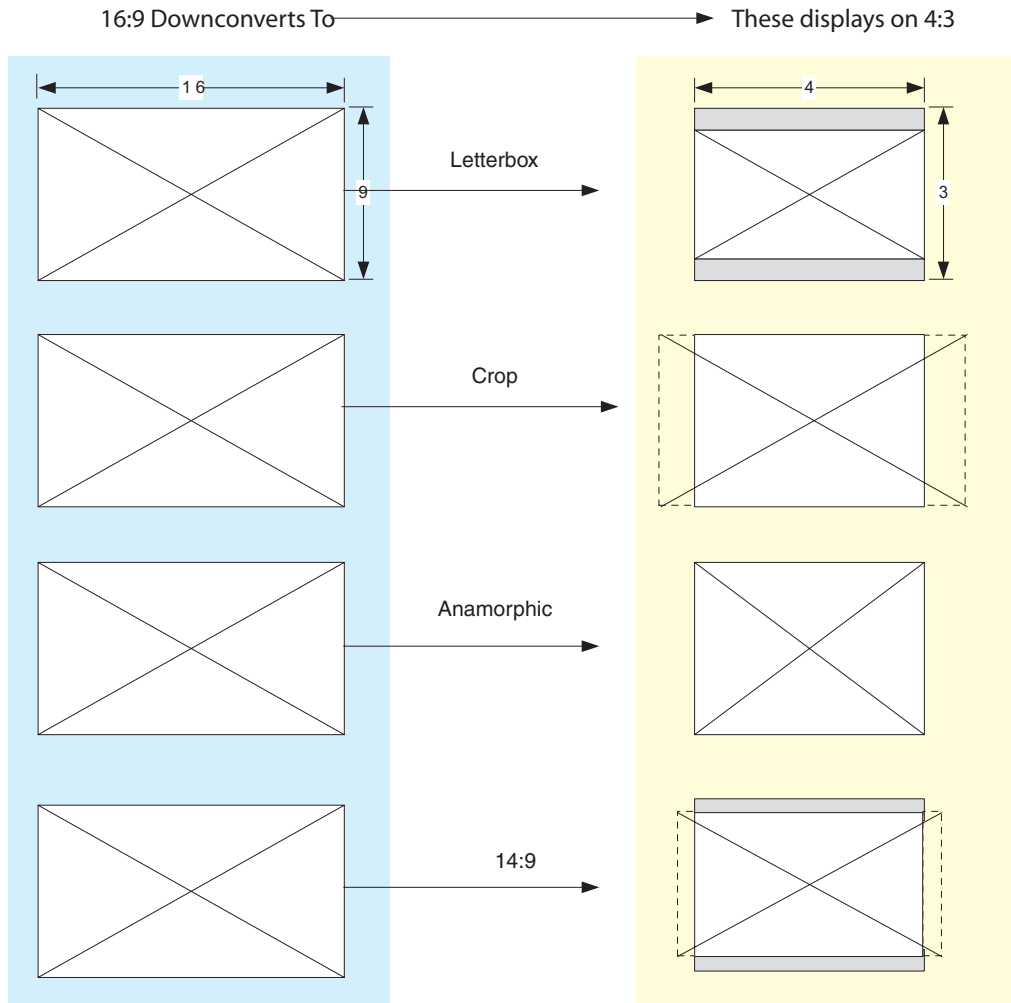

Aspect Ratio

This parameter selects the type of SD-to-SD Aspect Ratio Conversion (ARC) performed on an incoming selected SD source. This parameter is in effect only when the input and output are both SD (525i or 625i). (In Europe 16:9 anamorphic video is also known as “wide screen” video.)

8 SD Aspect Ratio Convert

Off (default)	Turns aspect ratio conversion <i>Off</i> .
Letterbox	Converts 16:9 Anamorphic video to Letterbox video.
H Crop	Converts 16:9 Anamorphic video to 4:3 Standard video (crops left and right edges of video).
Pillarbox	Converts 4:3 Standard video to 16:9 Anamorphic video.
V Crop	Converts Letterbox video to 16:9 Anamorphic video.
14:9	Converts 16:9 Anamorphic video to 14:9 Cropped video.

SD Aspect Ratio Conversion Illustrations

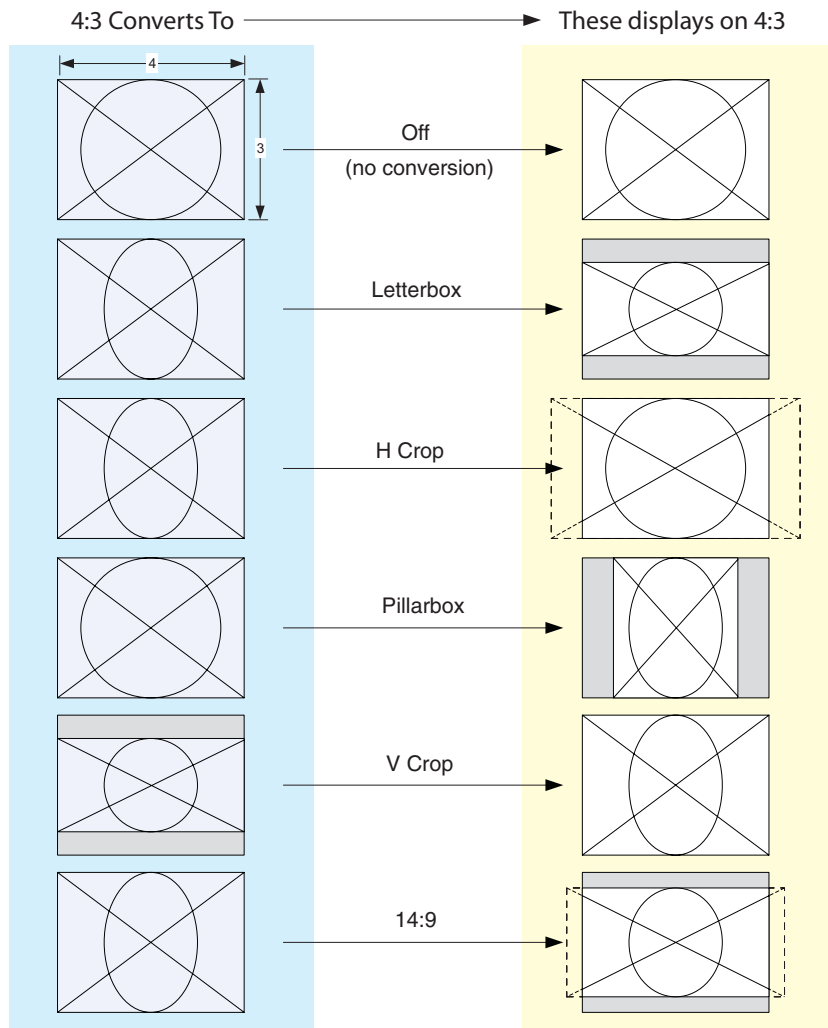

Sidebars

The parameter, which is hidden if *3 Video Output* is not set to *Sidebars*, adjusts the sidebar position where the center video meets the pillarbox background video on both sides. The underlying hardware feature is the same as *Custom Right Crop* and *Custom Left Crop*. This is effectively an extra handle on the *Left Crop* and *Right Crop* parameters.

The *Crop* and *Sidebar Edge* controls are additive; increasing *Sidebar Edge* (making the sidebars larger and the center-video smaller), equates to setting *Left* and *Right Crop* values to smaller percentages. The *Sidebar Edge* can be set to *0* through *+128*. A value of *0* produces a 4:3 center. Positive values produce wider sidebars (and a narrower center).

9 Sidebar Edge

<p>0 (default) 0 to +128 (Variable)</p>	<p>Defaults to 0. Select a width value from 0 through +128 to expand or shrink the sidebars, which are filled with Background video (4 Background Fill). Selecting a larger value causes the center picture to become narrower while the sidebars expand.</p>
---	---

Matte of Background Fill

10.1 Matte Luma This parameter determines the Matte Luma level of the background fill.

50% (<i>default</i>) 0–100% (Variable)	Sets the matte luminance level to the default 50% value. Sets the matte luminance level from 0–100%.
---	---

10.2 Matte Chroma This parameter determines the Matte Chroma level of the background fill.

50% (<i>default</i>) 0–100% (Variable)	Sets the matte chrominance level to the default 50% value. Sets the matte chrominance level from 0–100%.
---	---

10.3 Matte Hue This parameter determines the Matte Hue of the background fill.

0 degrees (<i>default</i>) 0–359 degrees (Variable)	Sets the matte hue to the default 0 degrees (red). Sets the matte hue to a value between 0 and 359 degrees.
--	--

NOTE: On the FS2 front panel, as you turn the Matte Hue ADJUST knob the values wrap from 359 back to 0 degrees.

Proc Amp Controls (YUV)

11.0 Proc Amp (YUV) This parameter turns the Proc Amp *On* and *Off* for signals composed of YUV components. When it is *On*, you can set additional parameters (11.1 to 11.4) to control video *Gain*, *Black Level*, *Hue*, and *Saturation*. Proc Amp parameter settings are independently kept for each separate input: *SDI 1*, *SDI 2*, *Fiber 1*, *Fiber 2*, *Composite*, *HDMI*, and *Component*.

Off (<i>default</i>) On	Sets the YUV Proc Amp to Off. Sets the YUV Proc Amp to On.
------------------------------	---

Source Memory Independent analog output timing values are kept for all available output formats.

11.1 Proc Amp Gain This parameter adjusts the video gain from 0 to 1.5 times luma in 0.01 steps

Variable	Adjusts Proc Amp Gain from zero to 1.5 in 0.01 steps. <i>Default (unity):</i> 1.0
----------	--

11.2 Proc Amp Black This parameter adjusts the video black level from -20 IRE to +20 IRE in 0.5 steps.

Variable	Adjusts Proc Amp Black level from -20 IRE to +20 IRE in 0.5 steps. <i>Default (unity):</i> 0 IRE
----------	---

11.3 Proc Amp Hue This parameter adjusts the video color hue through 360 degrees (color wheel) in 1 degree steps.

Variable	Adjusts Proc Amp Hue from -179 to +180 in steps of 1 degree. <i>Default (unity):</i> 0 degrees
----------	---

11.4 Proc Amp Sat This parameter adjusts the video color saturation from black and white to 1.5 times chroma in steps of 0.01.

Variable	Adjusts Proc Amp Saturation from 0 (black & white) to 1.5 (Chroma) in steps of 0.01. <i>Default: 1.0</i>
----------	---

Color Corrector (RGB)

12.0 Color Corrector (RGB) This parameter turns the RGB Color Corrector *On* and *Off*. When it is *On*, you can set additional parameters (12.1 to 12.9) to control RGB video *Gain*, *Black Level*, and *Gamma*. When set to *Off*, all RGB Color Corrector settings are programmed for unity (or bypass).

Off (default)	Sets the RGB Color Corrector to Off.
On	Sets the RGB Color Corrector to On, enabling parameters 12.1-12.9.

Source Memory RGB Color Corrector values are independently kept for each separate input: SDI 1, SDI 2, Fiber 1, Fiber 2, Composite, HDMI, and Component.

12.1 Color Red Gain This parameter adjusts the *RGB Red Gain*.

Variable	Adjusts Red Gain from zero to 1.5 in 0.01 steps. <i>Default (unity): 1.0</i>
----------	---

12.2 Color Red Black Level This parameter adjusts the *RGB Red Black* level.

Variable	Adjusts Red Black level from -20 IRE to +20 IRE in 0.5 steps. <i>Default (unity): 0 IRE</i>
----------	--

12.3 Color Red Gamma This parameter adjusts the *RGB Red Gamma*.

Variable	Adjusts Red Gamma level from -1.0 to +1.0 in 0.01 steps. <i>Default (unity): 0</i>
----------	---

12.4 -12.6 Color Green This set of parameters adjusts the Gain, Black Level, and Gamma for color Green, same as Color Red described above.

12.7-12.9 Color Blue This set of parameters adjusts the Gain, Black Level, and Gamma for color Red Blue, same as Color Red described above.

Custom Conversion Settings

The custom settings determine the image size and shape for Upconvert and Downconvert modes 6 and 7 if you choose the *Custom* selection for those modes.

Custom settings are stored separately for each Conversion Mode. Values for each of the Upconvert modes, Downconvert modes (excluding AFD), and SD Aspect Ratio modes (excluding OFF), plus no conversion (or HD CrossConvert), are independently stored (per Vid Proc).

NOTE: *If a Custom Setting parameter is not unity (100%) for the current mode, the front panel UFC LED lights.*

13.0 Custom Size/Pos This parameter turns custom image settings 13.1–13.8 *On* or *Off*.

On the front panel, when Hide Inactive is on, the *Custom* controls 13.1–13.8 are only displayed when *Custom Size/Pos* is *On*. When *Custom Size/Pos* is *Off*, parameters 13.1–13.8 are skipped in the menu system, and the UFC hardware is programmed for unity.

This menu is also not displayed when Active Format Description (AFD) is in control of the Conversion Mode. While downconverting, with Downconvert Mode set to Auto AFD, any values assigned for Custom Size/Pos parameters are ignored, and the menus are hidden.

Off (default) On	Sets this parameter and related custom size/pos parameters to off. Enables this parameter and related custom size/position parameters.
---------------------	---

13.1 Custom Size This parameter changes the H and V size of the output picture by the specified percentage (%) while maintaining the current aspect ratio.

100% (default) 10% to 200%	Maintains 100% picture size for the selected format. Enables changing the picture size.
-------------------------------	--

13.2 Custom Aspect This parameter changes the H/V aspect ratio of the output picture while maintaining the current V size (Aspect < 0) or H size (Aspect > 0).

0.000 (default) -0.500 to +0.500	Maintains the normal 100% aspect ratio for the selected format. Enables changing the aspect ratio.
-------------------------------------	---

13.3 Custom H Position This parameter changes the H position of the output picture.

0% (default) -100% to +100%	Maintains the normal horizontal position of the selected format. Enables changing the horizontal position.
--------------------------------	---

13.4 Custom V Position This parameter changes the V position of the output picture.

0% (default) -100% to +100%	Maintains the normal 100% vertical position of the selected format. Enables changing the vertical position.
--------------------------------	--

13.5 Custom Left Crop This parameter changes the Left picture crop position.

100% (default) +10.0% to +100.0%	Maintains the normal left side position of the selected format. Enables changing the left side position.
-------------------------------------	---

13.6 Custom Right Crop This parameter changes the Right picture crop position.

100% (default) +10.0% to +100.0%	Maintains the normal right side position of the selected format. Enables changing the right side position.
-------------------------------------	---

13.7 Custom Top Crop This parameter changes the Top picture crop position.

100% (default) +10.0% to +100.0%	Maintains the normal top position of the selected format. Enables changing the top position.
-------------------------------------	---

13.8 Custom Bottom Crop This parameter changes the bottom picture crop position.

100% (default) +10.0% to +100.0%	Maintains the normal bottom position of the selected format. Enables changing the bottom position.
-------------------------------------	---

Region of Interest (ROI)

The *Region of Interest* parameters (14.0–14.4) select a portion of the input picture that will be used for scaling and/or positioning. This feature can be useful for focusing in on computer video that is less than full screen, such as the contents of a movie player window. The selected area can then be scaled to a standard pillarbox or letterbox size and shape (*On Square*), or it can be set to a full screen input image (*On Full*).

NOTE: *On Full* may cause image distortion if it is used to expand an odd-shaped region of interest to full screen.

The *ROI Setup* mode allows you to preview the edges of your selected *Region Of Interest* as you set it up. After selecting the desired region using the Setup Cursor, you can take the region to air by setting *Region Of Interest* to *On Square* or *On Full*.

Note that the *Setup* mode is not required to operate the ROI feature. The edges of the Region Of Interest can also be adjusted while in *On Square* or *On Full* modes

14.0 Region of Interest This parameter turns the Region of Interest settings *On* or *Off*. When enabled, the *ROI Left*, *Right*, *Top*, and *Bottom* controls (14.1–14.4) define the rectangular shape and position of the ROI.

Off (<i>default</i>)	Turns off the ROI feature.
Setup	Enables ROI cursor.
On Square	Enables ROI and sets video to a pillarbox or letterbox shape.
On Full	Enables ROI, and expands the ROI area to full screen.

Interactions occur between ROI settings and other parameters:

- The *Region of Interest* menu is not displayed when *Active Format Description (AFD)* is in control of the Conversion Mode. While downconverting, with *Downconvert Mode* set to *Auto AFD*, any values assigned for *Custom Size/Pos* parameters are ignored, and the menus are hidden.
- *Custom Size and Position* settings work interactively with ROI, but *Custom Crop* settings are disabled. *Custom Size/Pos* is also temporarily disabled while in the *ROI Setup* mode.

14.1 ROI Left This parameter sets the left boundary of the ROI when parameter 14.0 is on.

Variable (<i>default=100%</i>)	Sets ROI left boundary to 10-100% of full screen in 0.1% increments. For 1% increments, hold down the Video button.
----------------------------------	---

14.2 ROI Right This parameter sets the right boundary of the ROI when parameter 14.0 is on.

Variable (<i>default=100%</i>)	Sets ROI right boundary to 10-100% of full screen in 0.1% increments. For 1% increments, hold down the Video button.
----------------------------------	--

14.3 ROI Top This parameter sets the top boundary of the ROI when parameter 14.0 is on.

Variable (<i>default=100%</i>)	Sets ROI top boundary to 10-100% of full screen in 0.1% increments. For 1% increments, hold down the Video button.
----------------------------------	--

14.4 ROI Bottom This parameter sets the bottom boundary of the ROI when parameter 14.0 is on.

Variable (<i>default=100%</i>)	Sets ROI bottom boundary to 10-100% of full screen in 0.1% increments. For 1% increments, hold down the Video button.
----------------------------------	---

Timing and Delay

These parameters adjust Video Processor horizontal and vertical output timing in reference to the genlock source already selected, and permits adding up to 6 full frames of output delay.

NOTE: Unlike most knob-adjustable parameters, on the front panel menu this parameter automatically wraps around from the maximum value to 0 (and vice versa).

Output Timing Memory Independent horizontal and vertical timing values are kept for all available output formats.

15.1 Output Timing H When adjusting the horizontal timing (H), this parameter specifies a number of pixels to offset, from zero to full line width. Adjustment range increments from 0 to the width of the line in pixels. The maximum value varies, depending on the format already chosen.

Variable	Adjustment range increments from 0 to the width of the line in pixels. The maximum varies, depending on the format chosen. <i>Default: 0</i>
----------	---

15.2 Output Timing V When adjusting the vertical timing (V), this parameter specifies a number of lines to offset, moving the screen up to a half a frame up or down.

Variable	Adjustment range increments from half a frame up to a half a frame down in single line increments. The maximum varies, depending on the format already chosen. <i>Default: 0</i>
----------	---

15.4 Extra Frame Delay This parameter adjusts Video Processor output timing.

Variable	Adjustment output timing from 0 to 6 frames down in one frame increments. <i>Default: 0</i>
----------	--

Video Legalizer

These parameters allow adjustment of signal levels to meet legal broadcast requirements.

16.0 Video Legalizer This parameter determines the Video Legalizer mode. When set to *Off*, the Video Legalizer is not enabled, and the following clip controls are not active. In *YUV* mode, the *White Clip*, *Black Clip*, and *Chroma Clip* controls are enabled and clip any luma/chroma that exceed the set limits. In *RGB* mode only the *White Clip* and *Black Clip* controls are active and limit the R, G, and B values to those settings. RGB mode requires the video to pass through the RGB Proc Amp to be converted to and from RGB.

Off (default)	Disables the Video Legalizer.
YUV	Enables the Video Legalizer to clip YUV to legal levels.
RGB	Enables the Video Legalizer to clip RGB to legal levels.

16.1 Legalizer White Clip When the Video Legalizer mode is *YUV* or *RGB*, this parameter limits the white level so that it does not exceed the adjusted limit. Limit can be set from +80 IRE to +120 IRE.

Variable	Adjusts white clip level from +80 IRE to +120 IRE in 0.5 steps. <i>Default (unity): 100 IRE</i>
----------	--

16.2 Legalizer Black Clip When the Video Legalizer mode is YUV or RGB, this parameter limits the black level to the adjusted limit. Limit can be set from -10 IRE to +20 IRE,.

Variable	Adjusts black level limit from -10 IRE to +20 IRE in 0.5 steps.
Default (unity): 0 IRE	

16.3 Legalizer Chroma Clip When the Video Legalizer mode is YUV, this parameter limits the maximum chroma level to the adjusted limit. The limit can be set from +60% to +140%,.

Variable	Adjusts chroma clip level from +60% to +140% in 0.5 steps.
Default (unity): 100 IRE	

AFD

These parameters determines if and where the Video Processor will insert a SMPTE 2016 Active Format Descriptor (AFD) packet into its output video. The inserted AFD code does not affect the Video Processor's up/down/cross conversion, but it may affect downstream video processing if the signal is Downconverted.

NOTE: AFD codes are only inserted into HD video outputs.

17.1 AFD Out SDI 1/2 These determines whether the Video Processor inserts an ADF packet into the output video.

OFF (default)	The FS2 does not insert an AFD code into the output. If the video input has a AFD code and the FS2 is not up/down/cross-converting it, the input AFD code will be passed through to the output.
Auto	If the FS2 is not Upconverting or Downconverting the input video, the input AFD code is passed through. If there is no AFD code on the input video, a "Full Frame" (8) code is inserted. If the FS2 is Upconverting, the appropriate AFD code will be chosen based on the Upconvert mode.
>16:9	The FS2 always inserts a "Box > 16:9 (center)" AFD code (4), which indicates that the HD image has an aspect ratio greater than 16:9 as a vertically centered letterbox within the 16:9 frame.
Full Frame	The FS2 always inserts a "Full Frame" AFD code (8), which indicates that the HD image is full frame, with an aspect ratio that is 16:9.
Pillarbox	The FS2 always inserts a "4:3 (center)" AFD code (9), which indicates that the HD image has a 4:3 aspect ratio as a horizontally center pillarbox image within the 16:9 frame.
Letterbox	The FS2 always inserts a "16:9 (with complete 16:9 image protected)" AFD code (10), which indicates that the HD image is full frame, with a 16:9 aspect ratio and all image areas are protected.
14:9	The FS2 always inserts a "14:9 (center)" AFD code (11), which indicates that the HD image has a 14:9 aspect ratio as a horizontally centered pillarbox within the 16:9 frame.
4:3 Alt 14:9	The FS2 always inserts a "4:3 (with alternate 14:9 center)" AFD code (13), which indicates that the HD image has a 4:3 aspect ratio and with an alternative 14:9 centered pillarbox image within the 16:9 frame.
16:9 Alt 14:9	The FS2 always inserts a "16:9 (with alternative 14:9 center)" AFD code (14), which indicates that the HD image has a 16:9 aspect ratio with an alternative 14:9 center within the 16:9 frame.
16:9 Alt 4:3	The FS2 always inserts a "16:9 (with alternative 4:3 center)" AFD code (15), which indicates that the HD image has a 16:9 aspect ratio with an alternative 4:3 center within the 16:9 frame.

17.2 AFD VANC Output Lines This parameter determines which video output lines have AFD VANC inserted (HD output only) on the Video Processor output.

10 (default) 9–42	Adds AFD VANC to line 10. Select which line other than 10 will have AFD VANC added.
----------------------	--

17.3 Downcvrt AFD Dflt This parameter selects how the Video Processor will operate when parameter 7 Downconvert Mode has been set to Auto AFD and no AFD codes are detected at the selected input source (that is, this menu selects the default Downconversion to use when AFD is absent). This parameter is in effect only when the input is HD (720p, 1080i, or 1080p) and the selected output format is SD (525i or 625i).

Hold Last (default)	Use the last detected AFD code and continue to use its aspect ratio until a new AFD code is detected again in the SDI metadata.
Crop	When AFD code is absent, switch the Downconverter mode to Crop.
Anamorphic	When AFD code is absent, switch the Downconverter mode to Anamorphic.
14:9	When AFD code is absent, switch the Downconverter mode to 14x9.
Letterbox	When AFD code is absent, switch the Downconverter mode to Letterbox.

Closed Captioning This parameter translates closed captioning from the SD CEA-608 format on line 21 to the HD CEA-708 format and inserts it into the HD output video stream.

NOTE: This parameter interacts with parameter 20 SD Line 21 Blanking; see the explanation for that parameter also.

18 Caption Xlator

On (Upconverter)	When set to On and using the Upconverter, the FS2 will automatically translate incoming line 21 captions to CEA-708 format and insert the VANC packets into the converted HD video stream. This is a complete translation from CEA-608 format to CEA-708 format (including the embedded SD captions).
On (Downconverter)	When set to On and using the Downconverters, the FS2 will automatically intercept and reformat the SD caption data in the incoming CEA-708 VANC packets, and output it on line 21 of the standard definition outputs.
Off (default)	When Off, caption translation is not performed.

In standard definition video (525i/59.94), closed captioning data is encoded and sent on line 21 of both fields, using a format defined by the Consumer Electronics Association standard, CEA-608. This is traditionally called “line 21”, “SD”, or “608” captioning, and is used for analog composite, analog component, and serial digital (SDI) video.

In high definition video, closed captioning is encoded and sent as Vertical Ancillary (VANC) packets in SDI video, using a format defined by the Consumer Electronics Association standard CEA-708 (there is no equivalent for analog HD video). This is

traditionally called "HD," "DTV," or "708" captioning. The data formatting and encoding for 708 captions is very different from the data contained in 608 (SD) captioning, reflecting the added features and capabilities available with the CEA-708 standard.

When the Caption Translator is on, the FS2 Upconverter automatically translates incoming line 21 captions to CEA-708 format and inserts the VANC packets into the converted HD video stream. This is a complete translation from CEA-608 format to CEA-708 format (including the embedded SD captions).

The FS2 Downconverters automatically intercept and reformat the SD caption data in the incoming CEA-708 VANC packets, and output it on line 21 of the standard definition outputs.

Input Scan and PSF

This parameter determines how the Deinterlacer handles interlaced vs. PsF inputs. Normally, this control will only be used to indicate that a 1080PsF25 input is PsF and not interlaced.

- Auto** When Auto is selected, the system will look for clues in the source's SMPTE 352 (Payload ID) data and respond accordingly. If there is no SMPTE 352 information, the system will assume that 23.98/24 fps sources are PsF, and 25/29.97/30 fps sources are interlaced.
- Progressive** When Progressive is selected, the system will assume that all sources are PsF (even if there is SMPTE 352 data to the contrary).
- Interlaced** When Interlaced is selected, the system will assume that all sources are interlaced (even if there is SMPTE 352 data to the contrary)

19 Input Scan Format .

Auto (default)	Deinterlacer detects input source payload ID data and sets the processing format accordingly.
Progressive	Assumes all input sources are progressive.
Interlaced	Assumes all input sources are interlaced.

SD Line 21 Closed Caption Blanking

This parameter determines whether the FS2 blanks line 21 closed captioning data prior to video processing of an SD 525i video input. (Line 21 normally occurs at the top of the raster in the overscan area of video, so the presence of captioning data or blanking does not interfere with the visible SD or Upconverted video.)

20 SD Line 21 Blanking

- Blank** In Blank mode, the FS2 copies and remembers the contents of SD line 21 and then blanks those lines before transformation to ensure captioning data does not get included in the transformed video. If the output video is SD 525i, the copied caption information gets reinserted on line 21 of the output. If the output video is Upconverted and parameter 18 Caption Xlator is On, the copied caption gets translated into an HD caption and inserted into the transformed output (and if the caption translator is Off, the HD output does not contain caption data). This is the setting to use if the SD input includes a caption and you want to retain it at the output (parameter 18 Caption Xlator must be On), or you want to blank it at the output (18 Caption Xlator must be Off).
- Pass** In Pass mode, the FS2 does not blank line 21 of the SD video input and passes the unaltered video to the Video Processor for transformation. This is the setting to use if there is no captioning data present on line 21 of a 525i video input.

Auto blank In Auto Blank mode, the FS2 automatically detects presence or absence of line 21 caption data on the SD input. If no line 21 caption is present, the FS2 passes the video unaltered. If line 21 data is detected, the FS2 copies the data, blanks line 21, and reinserts translated captioning on the transformed HD output if parameter 18 Caption Xlator is On. If the Caption Translator is Off, the HD output will not contain captioning. This is the setting to use if your SD input video sometimes contains captions and other times does not, or if you are uncertain which setting to use.

Blank (default)	In Upconvert or SD Aspect Ratio Convert modes, this setting copies caption data and blanks 525i input video Line 21 caption data before conversion, and may or may not include that data (see above).
Pass	Passes input video unaltered to the converter and to the outputs.
Auto blank	The FS2 automatically detects caption data on SD input, passing unaltered video if no line 21 caption is present, and reinserting caption data if 18 Caption Xlator is On.

Test Pattern

This parameter selects the video source for the Test Pattern Generator. The pattern generator is turned off and on using Output parameter 3 Video Output mode.

21 Test Pattern Video

75% Bars (default)	Sets the test pattern to 75% bars.
Ramp	Sets the test pattern to ramp.
Multiburst	Sets the test pattern to a multiburst.
Flat Field	Sets the test pattern to flat field chroma.
Black	Sets the test pattern to black.
100% Bars	Sets the test pattern to 100% bars.

Freeze

This parameter tells the FS2 to freeze the current video frame on all outputs. This may be useful either for testing or in case of loss of the input source.

22 Freeze Output

Off (default)	Normal operation. The FS2 outputs video from the input.
On	The FS2 captures and freezes the most current video frame and displays it on the outputs as long as this parameter is set to On.

The freeze feature can be controlled not only by the front-panel and web browser interface, but also by a GPI input. When a GPI input is causing the freeze condition, the EXT lamp will be lit on the front-panel.

AUDIO 1 and AUDIO 2 Menu Groups

The Audio Menus control the FS2's audio routing and signal processing. Because the selections for the video processors are identical, both are described here.

1.0 Audio Input

This parameter performs input audio source selection for Audio Processor 1. Multiple input sources may be present at all the connectors on the FS2 rear panel, but the active input source routed through the FS2 is the one selected here.

AES/EBU (default)	Selects the AES/EBU digital audio input (16-ch) as the input source.
Analog	Selects the Analog audio connector (DB25, 8-ch) as the input source. Input channels 9-16 are set to Mute.
Embed SDI1	Uses the embedded audio from the SDI 1 video input as the input source.
Embed SDI2	Uses the embedded audio from the SDI 2 video input as the input source.
Embed Fiber1	Uses the embedded audio from the optional Fiber 1 video input as the input source.
Embed Fiber2	Uses the embedded audio from the optional Fiber 2 video input as the input source.
HDMI	Uses the embedded audio from the HDMI video input (8-ch) as the input source. Input channels 9-16 are set to Mute.
Dolby Decode	Selects the Dolby Decoder output as the audio processor input.
Mute	Sets all input channels to Mute.
Channel Map	For the 16 channels of audio input, selects inputs according to Audio Map parameters 1.1 through 1.16. Any of the 16 embedded channels can be mapped to one of the 96 sources.
Stereo Map	For the 16 channels of audio input, selects stereo inputs according to Audio Map parameters 1.17 through 1.24. Any channel pair (8 pair total) can be mapped to 48 different choices.

NOTE: *If parameter 3 Audio Follow Video is set to On, the Audio Input selection is independently remembered for each video input. When Audio Follow Video is Off, audio for each video input is not remembered and you must manually select the audio source you want. If you have never manually selected the audio source, the factory default audio selection is used.*

1.1–1.16 Audio Map Ch1–16

When Channel Map is selected in parameter 1, these Map parameters for Audio Channels 1–16 map an audio source to each audio output channel. Available source selections for the audio output channels are listed in the following table. The default selections are AES Ch1–16 for Audio Output Channels 1–16, respectively.

Available Selections	AES Ch 1 (default)	SDI 1 Ch 1	Fiber 1 Ch1	HDMI Ch1
	AES Ch 2 (default)	SDI 1 Ch 2	Fiber 1 Ch2	HDMI Ch2
	AES Ch 3 (default)	SDI 1 Ch 3	Fiber 1 Ch3	HDMI Ch3
	AES Ch 4 (default)	SDI 1 Ch 4	Fiber 1 Ch4	HDMI Ch4
	AES Ch 5 (default)	SDI 1 Ch 5	Fiber 1 Ch5	HDMI Ch5
	AES Ch 6 (default)	SDI 1 Ch 6	Fiber 1 Ch6	HDMI Ch6
	AES Ch 7 (default)	SDI 1 Ch 7	Fiber 1 Ch7	HDMI Ch7
	AES Ch 8 (default)	SDI 1 Ch 8	Fiber 1 Ch8	HDMI Ch8
	AES Ch 9 (default)	SDI 1 Ch 9	Fiber 1 Ch9	Dolby Ch1
	AES Ch10 (default)	SDI 1 Ch10	Fiber 1 Ch10	Dolby Ch2
	AES Ch11 (default)	SDI 1 Ch11	Fiber 1 Ch11	Dolby Ch3
	AES Ch12 (default)	SDI 1 Ch12	Fiber 1 Ch12	Dolby Ch4
	AES Ch13 (default)	SDI 1 Ch13	Fiber 1 Ch13	Dolby Ch5
	AES Ch14 (default)	SDI 1 Ch14	Fiber 1 Ch14	Dolby Ch6
	AES Ch15 (default)	SDI 1 Ch15	Fiber 1 Ch15	Dolby Ch7
	AES Ch16 (default)	SDI 1 Ch16	Fiber 1 Ch16	Dolby Ch8
	Analog Ch 1	SDI 2 Ch 1	Fiber 2 Ch1	Dolby Aux1
	Analog Ch 2	SDI 2 Ch 2	Fiber 2 Ch2	Dolby Aux2
	Analog Ch 3	SDI 2 Ch 3	Fiber 2 Ch3	Mute
	Analog Ch 4	SDI 2 Ch 4	Fiber 2 Ch4	
	Analog Ch 5	SDI 2 Ch 5	Fiber 2 Ch5	
	Analog Ch 6	SDI 2 Ch 6	Fiber 2 Ch6	
	Analog Ch 7	SDI 2 Ch 7	Fiber 2 Ch7	
	Analog Ch 8	SDI 2 Ch 8	Fiber 2 Ch8	
		SDI 2 Ch 9	Fiber 2 Ch9	
		SDI 2 Ch 10	Fiber 2 Ch10	
		SDI 2 Ch 11	Fiber 2 Ch11	
		SDI 2 Ch 12	Fiber 2 Ch12	
		SDI 2 Ch 13	Fiber 2 Ch13	
		SDI 2 Ch 14	Fiber 2 Ch14	
		SDI 2 Ch 15	Fiber 2 Ch15	
		SDI 2 Ch 16	Fiber 2 Ch16	

1.17–1.24 Audio Map Ch 1/2–15/16

When Stereo Map is selected in parameter 1, these Map parameters for Audio Channels 1/2–15/16 map a pair of audio sources to each audio output channel pair. Available source pair selections for the audio output channel pairs are listed in the following table. The default selections are AES Ch1/2–AES 15/16 for Audio Output Channels 1/2–15/16, respectively.

Available Selections	AES Ch1/2 (default)	SDI 1 Ch1/2	Fiber 1 Ch1/2	HDMI Ch1/2
	AES Ch3/4 (default)	SDI 1 Ch3/4	Fiber 1 Ch3/4	HDMI Ch3/4
	AES Ch5/6 (default)	SDI 1 Ch5/6	Fiber 1 Ch5/6	HDMI Ch5/6
	AES Ch7/8 (default)	SDI 1 Ch7/8	Fiber 1 Ch7/8	HDMI Ch7/8
	AES Ch9/10 (default)	SDI 1 Ch9/10	Fiber 1 Ch9/10	Dolby Ch1/Ch2
	AES Ch11/12 (default)	SDI 1 Ch11/12	Fiber 1 Ch11/12	Dolby Ch3/Ch4
	AES Ch13/14 (default)	SDI 1 Ch13/14	Fiber 1 Ch13/14	Dolby Ch5/Ch6
	AES Ch15/16 (default)	SDI 1 Ch15/16	Fiber 1 Ch15/16	Dolby Ch7/Ch8
	Analog Ch1/2	SDI 2 Ch1/2	Fiber 2 Ch1/2	Dolby Aux
	Analog Ch3/4	SDI 2 Ch3/4	Fiber 2 Ch3/4	Mute
	Analog Ch5/6	SDI 2 Ch5/6	Fiber 2 Ch5/6	
	Analog Ch7/8	SDI 2 Ch7/8	Fiber 2 Ch7/8	
	Analog Ch1/2	SDI 2 Ch9/10	Fiber 2 Ch9/10	
	Analog Ch3/4	SDI 2 Ch11/12	Fiber 2 Ch11/12	
	Analog Ch5/6	SDI 2 Ch13/14	Fiber 2 Ch13/14	
	Analog Ch7/8	SDI 2 Ch15/16	Fiber 2 Ch15/16	

2 Embedded Audio Out

This parameter turns embedded audio in the Processor output video to On, Mute, or Off.

On (default)	Turn audio embedding On at the Processor output.
Mute	Embeds but mutes audio on the Processor output.
Off	Turns audio embedding Off at the Processor output

The FS2 does not support embedded audio output for the following formats:

- 2K1080p 29.97 or 2K1080p 30
- 2K1080p 59.94 or 2K1080p 60 when 3G Config is set to 3 Gb Level B or 1.5 Gb DualLink.

Embedded audio is available for 3 Gb Level A format.

3 Audio Follow Video

This parameter determines whether audio settings are remembered for each video input.

Off (default)	Normal operation. Audio settings must be made separately from any video settings; they are not associated automatically.
On	The FS2 remembers the saved audio settings associated with the currently selected video input.

When AFV is Off, you must manually select the audio you want for a selected video input, and that audio source remains selected until you change it. If the audio source has never been selected, the factory default audio source is used.

When AFV is On, the FS2 remembers the saved audio settings associated with the currently selected video input. Whenever a new video input is selected, the corresponding audio settings are recalled. This allows you to set up specific audio

settings for the different video inputs (i.e., perhaps the SDI 1 has a specific embedded audio channel mapping while the component video input might always use AES audio input).

Audio Follow Video applies to these parameters:

- 1 Audio Input
- 1.1—1.16 Audio Map
- 1.17—1.24 Audio Map (Stereo)
- 6.0 Audio Delay
- 7.0 Audio Output Levels
- 7.1—7.16 Audio Level Ch (n)
- 8.0 Audio Output Phase
- 8.1—8.16 Audio Phase Ch (n)

NOTE: Turning Audio Follow Video (AFV) On results in the loss of the above settings. When AFV is turned On, the source-memory settings are written over the current settings. Turning AFV Off again will not restore the original settings, but instead will result in the source memory settings remaining in effect until edited again.

4 Audio Signal Gen

This parameter determines the audio signal output from the FS2's internal test signal generator.

Off (default)	Turn audio test signal output OFF.
400 Hz	Output a standard 400 Hz test signal tone.
1 kHz	Output a standard 1 kHz test signal tone.

Audio Delay Controls

6.0 Audio Delay (mS) This parameter is available only when the audio input (parameter 1) is set to AES/EBU, Analog, Embedded, or HDMI. The parameter allows you to adjust the audio delay to compensate for video timing (delay/latency). The default is zero delay.

Variable	Adjustment range increments from -16 to +256 mS or -768 samples to +12288 samples. Default=0 (synchronized to video output).
----------	---

If parameter 3 Audio Follow Video is set to On, the Audio Delay selection is independently kept for each separate input. If Audio Follow Video is set to Off, a single Audio Delay value applies, regardless of the video input. (This value is independent of any of the values used in Audio-Follow-Video mode.)

NOTE: The Delay menu for a particular channel-pair may be hidden if that channel pair is controlled by the Dolby Framer (see 9.0 Dolby Framer Sync).

6.1-16 Audio Delay Ch1-16 (mS) These parameters apply only when the audio input (parameter 1) is set to Channel Map. The parameters allow you to adjust the audio delay to compensate for video timing (delay/latency). The default is zero delay).

Variable	Adjustment range increments from -16 to +256 mS or -768 samples to +12288 samples. Default=0 (synchronized to video output).
----------	---

If parameter 3 Audio Follow Video is set to On, the Audio Delay selection is independently kept for each video input. If Audio Follow Video is set to Off, a single Audio Delay value applies, regardless of the video input. (This value is independent of any of the values used in Audio-Follow-Video mode.)

NOTE: This menu is not displayed when Dolby Framer Sync is in control of the delay for a channel. While Dolby Framer Sync is enabled, and the Dolby Framer Input is assigned to channels x/y, any values assigned for Audio Delay Ch x or Audio Delay Ch y parameters are ignored, and those menus are hidden.

6.17-24 Audio Delay Ch1/2-15/16(mS) These parameters apply only when the audio input (parameter 1) is set to Stereo Map. The parameters allow you to adjust the stereo audio delay to compensate for video timing (delay/latency). The default is zero delay).

Variable	Adjustment range increments from -16 to +256 mS or -768 samples to +12288 samples. Default=0 (synchronized to video output).
----------	---

NOTE: This menu is not displayed when Dolby Framer Sync is in control of the delay for a channel-pair. While Dolby Framer Sync is enabled, and the Dolby Framer Input is assigned to channels x/y, any values assigned for the Audio Delay Ch x/y parameters are ignored, and those menus are hidden.

If parameter 3 Audio Follow Video is set to On, the Audio Delay selection is independently kept for each video input. If Audio Follow Video is set to Off, a single Audio Delay value applies, regardless of the video input. (This value is independent of any of the values used in Audio-Follow-Video mode.)

Audio Output Level Controls

7.0 Audio Out Levels This parameter enables or disables individual audio output level adjustment of the 16 audio output channels. When ADJUST is selected, parameters 7.1 through 7.16 set the output levels for each separate channel.d

Unity (default)	Disable audio output level adjustments and set levels to unity.
Adjust	Enable audio output level adjustments for the 16 audio channels.

If parameter 3 Audio Follow Video is set to On, the Audio Output Levels selection is independently kept for each video input. If Audio Follow Video is set to Off, a single Audio Output Levels value applies, regardless of the video input. (This value is independent of any of the values used in Audio-Follow-Video mode.)

7.1–7.16 Audio Level Ch1–16 These 16 parameters adjust the audio levels of the 16 audio channels ± 18dB dB.

Variable	Adjustment of audio level +/-18 dB range in steps of 0.5dB. Default: +0dB
----------	--

Audio Output Phase Controls

8.0 Audio Output Phase This parameter enables or disables individual audio phase adjustment of the 16 audio output channels. When Adjust is selected, parameters 8.1 through 8.16 are then used to adjust phase for the 16 channels.

Unity (default)	Disable audio phase adjustments and set phase to unity.
Adjust	Enable audio phase adjustments for the 16 audio channels.

If parameter 3 Audio Follow Video is set to On, the Audio Output Phase selection is independently kept for each video input. If Audio Follow Video is set to Off, a single Audio Delay value applies, regardless of the video input. (This value is independent of any of the values used in Audio-Follow-Video mode.)

8.1–8.16 Audio Phase Ch1–16 These parameters select whether audio phase is normal (same as passed from the input) or inverted on Channels 1–16. This may be useful to correct analog audio signals that are incorrectly wired, placing audio out of phase at input.

Normal (default)	Phase is unaltered as it passes from the input to the output.
Invert	Phase is inverted as it passes from the input to output.

If parameter 3 Audio Follow Video is set to On, then Audio Output Phase selection is independently kept for each video input. If Audio Follow Video is set to Off, then the last setting you made for Audio Output Phase is used.

Dolby Framer Controls

9.0 Dolby Framer Sync This parameter enables or disables automatic timing correction of the Dolby E signal.

Off (default)	No Dolby E timing synchronization with vertical blanking. Normal Audio Delay parameters are enabled
On	Dolby E timing is auto-corrected to the minimum delay possible to synchronize with the video blanking interval. Normal Audio Delay parameters for the corresponding Dolby Framer Input channel pair are disabled.
Offset	Dolby E timing is first auto-corrected to a nominal delay while synchronizing with the video blanking interval. Then the delay is further adjusted by the Offset specified in 9.2 Dolby Framer Offset (Frames) and 9.3 Dolby Framer Offset (Samples). Normal Audio Delay parameters for the corresponding Dolby Framer Input channel pair are disabled.

In ON and OFFSET modes, if 1.0 Audio Input is set to Channel Map or Stereo Map, the 6.x Audio Delay menus for that pair are hidden.

If the Dolby Framer cannot lock the audio signal to the video output, an alarm is triggered. (This may happen with non-Dolby E signals, or with Dolby E signals having an incompatible frame rate.)

The Dolby Framer is incompatible with audio Channel Map mode. It works only with Stereo Map or single-source audio inputs capable of carrying Dolby E pairs. If the Dolby Framer is enabled while the input source is set to Channel Map, Analog, HDMI, or Dolby Decoder, an alarm will result, and the Dolby Framer status will be shown as "Conflict". Also note that Dolby Decoder is not a valid Framer source, since the Dolby is already decoded into PCM audio by the time it reaches the audio processor.

Dolby Framer status is available on the front panel Dolby Framer status menu or the Status page of the web UI.

9.1 Dolby Framer Input This parameter is visible only if 9.0 Dolby Framer Sync is set to On or Offset; the parameter is hidden when 9.0 is set to Off.

The Dolby Framer Input can sync incoming Dolby E bit streams to the local reference so they can maintain A/V sync when recorded onto VTRs or servers or when passing through downstream facilities. You can set which pair of channels contains the Dolby E stream to output synchronized with the reference. The Dolby Framer Input feature only works with Dolby E inputs.

Dolby input pair	Ch 1/2, 3/4, 5/6, 7/8, 9/10, 11/12, 13/14, 15/16. Ch 1/2 is default
------------------	--

9.2 Dolby Framer Offset (Frames) This parameter is visible only if 9.0 Dolby Framer Sync is set to Offset; the parameter is hidden when 9.0 is set to Off or On. The parameter adjusts the audio delay in frames, providing a coarse timing adjustment.

Variable (frames)	Sets the delay of the Dolby E audio stream relative to the video frame. The minimum is 0 frames and maximum is +6 frames.
-------------------	---

9.3 Dolby Framer Offset (Samples) This parameter is visible only if 9.0 Dolby Framer Sync is set to Offset; the parameter is hidden when 9.0 is set to Off or On. The parameter adjusts the audio delay in samples, providing a fine timing adjustment.

Variable	Sets the delay of the Dolby E audio stream relative to the video frame. The minimum is -768 samples and maximum is +768 samples.
----------	--

Chapter 5: Browser Remote Control

Remote FS2 Control Via a Web Browser

The FS2 web interface consists of a built-in optimized web server that provides control via a web browser running on a network-attached computer. The FS2 browser screens are presented and described on the following pages, organized as they appear in the browser. The description tables list the parameter menu numbers in parentheses so you can quickly relate screens to front panel menus.

- Supported browsers**
- Chrome (all platforms)
 - Firefox (all platforms)
 - Safari (OSX, Mobile)

Other browsers are likely to work but are not guaranteed.

- Supported RJ45 Ethernet network connections**
- Closed local area network (LAN)
 - Straight computer-to-FS2 cable connection
 - Broadband wide area network (WAN) with the firewall opened for the FS2 (not recommended since anyone on the internet can then access the FS2)

Internally the FS2 senses and adapts to either a “straight-through” CAT 5 Ethernet cable or null-modem (crossover) cable using standard RJ45 connectors. No setup or strapping is needed to adapt to the cable.

Browser connection to FS2 For browser access, enter the FS2 IP address in the browser's address field.

By default, the FS2 is set to automatically connect to your network's DHCP server to get an IP address and other network configuration data. You will find the IP address in *CONFIG* Menu Group parameter 2.2 as follows:

1. Press the *CONFIG* button on the FS2 front panel.
2. Turn the *SELECT* knob until you reach parameter 2.2 *IP Address*.
3. Enter the IP address shown in 2.2 in the browser address field.

When the browser successfully connects to the FS2, the main *Status* screen shown on the next page is displayed. If the browser fails to connect, make sure *CONFIG* settings 2.1 through 2.4 (*IP, subnet, and gateway addressing*) match the network setup of the browser host. You can either make the computer match the FS2, or make the FS2 match your computer.

General Web Browser Screen Description

The main Status screen appears below. All FS2 screens have common elements:

- Menu** On the left of each screen is a navigational list of the available FS2 screens. Click any of these items to jump to that screen.
- Alarms** The lower left side of the screen shows alarms that alert you to possible problem conditions, such as disconnected or failed power supplies and video format incompatibilities.

Status and Menu Display In the center of each screen you'll find the main display showing the status and menu selections for the screen you are viewing. The content of FS2 web screens closely mirrors the parameter menus displayed on the front panel; if you hover the cursor over any parameter, the equivalent front panel parameter number is displayed.

Connection The right side of the screen lists FS2 system details, including system serial number, installed software version, and connection status. This information is useful if you ever have to call AJA Technical Support for help.

Network The right side of the screen lists systems on the network. If you right-click any FS2 system in the list, the ID LEDs on the unit light to identify it. Another way to identify systems is to notice which FS2 system's EXT front panel LED blinks when you change any setting from a remote control device, such as the web browser.

Figure 11. FS2 Web Interface, Main Status Screen



Controlling Multiple FS2s From any screen, you can see at-a-glance all of the FS2 devices present on the same local LAN as well as the current FS2 you are controlling. Clicking on any of the listed systems will bring up the *Status* screen of that FS2.

NOTE: *The FS2 you control may be running a different software version, so screens may look different. It's a good idea to have all your FS2 devices running the most current software and the same version. Also, if the Default Gateway (parameter 2.4) is not configured properly, other FS2s will not be visible. If the display shows No FS2's found, check the gateway setting.*

Resetting Values To Factory Settings FS2 web browser screens feature many user controls that can be reset to factory values by simply "right-clicking" on the parameter label. When you right-click, the browser displays a *Reset to Factory* message that will cause the parameter to be reset.

NOTE: *This reset procedure only works with computers that allow right-clicking. Some computers may not permit this operation.*

You can perform a global reset to factory values of all System, Video 1/2, Audio 1/2, and Output parameters (the same set of parameters acted on by a Preset Recall).

To perform a global reset:

1. Go to the *Presets* screen.
2. Click on the *Recall* button in the *Factory Preset* row.

User preferences, network settings, and existing Presets are not affected by recalling the Factory Preset.

Clicking on the down arrow next to each parameter displays a drop-down list of available selections.

Drop Down Parameter Operation

Most FS2 parameters available on the browser are selected from a drop-down list. The currently active parameter is displayed. Click on the down arrow symbol next to the parameter to display the list and select an alternative value. The FS2 will immediately operate with the new setting.

Slider Operation

Some screens contain slider controls for setting values. To set a value, you can click on a slider to select it and then use the mouse to drag the slider to the position you desire. For fine tuning, while the slider is selected (highlighted by a blue border), use the keyboard left and right arrow keys to change the value one unit at a time. After setting a slider's position, click on the page's background area (blue highlight turns off) to ensure the change is confirmed and saved.

Video Format Display

When displaying video format status, the following convention differentiates between SMPTE video formats (broadcast) and VESA formats (non-broadcast formats originating from a computer DVI signal). The SMPTE formats are shown as height (in lines), scan-format (progressive or interlaced), and frame-rate, such as *1080i59*, for example. the VESA formats are shown as a size only, with an x in the middle, such as *640x480*, for example.

Screen Descriptions

Now that you have had an introduction to how the FS2 browser works and how to navigate the screens, each screen and its settings are described in detail. The screens are described in the order listed on main screen (click to jump):

- [“Network Pane and Network Configuration Screen” on page 88](#)
- [“Alarm Configuration Screen” on page 90](#)
- [“Status Screen” on page 90](#)
- [“System Screen” on page 92](#)
- [“Config Screen” on page 93](#)
- [“Presets Screen” on page 95](#)
- [“Output Screen” on page 96](#)
- [“Video 1 & 2 Screens” on page 97](#)
- [“Audio 1 and 2 Screens” on page 98](#)
- [“Remote Screen” on page 99](#)
- [“Firmware Screen” on page 100](#)

Network Pane and Network Configuration Screen

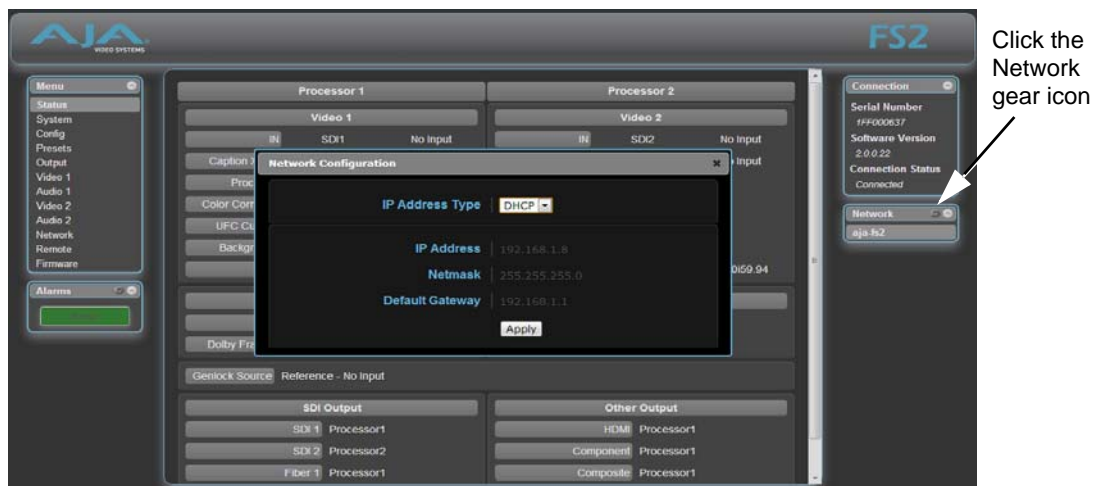

The *Network* pane on the right side of any screen lists the FS2 systems that appear on the network. This pane includes three additional controls:

- Hover the cursor over any system name to see its IP address.
- Right-click any system and select *Identify* to light the system *ID* LEDs.
- Click the gear-shaped icon in the *Network* pane (or select *Network* from the *Menu* list on the left side of the screen) to open the *Network Configuration* screen listing FS2 network settings.

The *Network Configuration* screen allows you to view and change your FS2's network settings and then click *Apply* to activate them.

See "[Networking](#)" on page 28 for detailed setup instructions for connecting the FS2 to a network. Consult your network administrator about how to configure network settings.

IP Address Type

IP Address Type determines the type of TCP/IP network configuration used by the FS2. *DHCP* enables the FS2 to connect to the network DHCP server, which assigns the *IP Address*, *Netmask*, and *Gateway* automatically. *Static* lets you set these parameters manually.

NOTE: *If the IP Address Type is DHCP, the IP Address, Netmask, and Default Gateway are gray, indicating they are set automatically and cannot be changed unless IP Address Type is first set to Static. Changes are saved and activated upon confirmation using the Apply button.*

DHCP (default)	Select automatic IP address assignment from the LAN DHCP server. If the FS2 cannot find a DHCP server, it fails over to the static IP address.
Static Addr	Assign a static IP address manually (using parameters 2.2, 2.3, and 2.4). The factory default static IP address: 192.168.0.2

IP Address

IP Address determines the static IP address used by the FS2 for TCP/IP networking. (Networking is discussed in *Chapter 3, Network Connection*.) Consult your network administrator about how to set this value.

Variable	If <i>IP Address Type</i> is set to <i>DHCP</i> , the IP address is set automatically by the network DHCP server and cannot be entered here. If <i>IP Address Type</i> is set to <i>Static</i> , enter an IP address compatible with your LAN here. Also enter a netmask and default gateway address in the following two parameters. Click <i>Apply</i> when you are ready to apply all three entries to change the FS2's network addressing. If <i>IP Address Type</i> is set to <i>DHCP</i> and there is a DHCP failure, the IP address is set to the static IP address. The default static IP address is 192.168.0.2
----------	--

Netmask

Netmask determines the subnet mask used by the FS2 for TCP/IP networking.

Variable	Enter a subnet mask compatible with your LAN. This is only needed for Static IP configurations. The factory default <i>Subnet Mask</i> is 255.255.255.0 If <i>IP Address Type</i> is set to <i>DHCP</i> , the Subnet Mask is set by the DHCP server and cannot be changed by the user.
----------	---

Default Gateway

Default Gateway determines the gateway or router used on your LAN for TCP/IP networking.

Without a properly configured default gateway (whether you have a router/gateway or not), the FS2 will be unable to see other FS2s on the network, although you may still be able to control this FS2 via a web browser. Also, without a proper gateway defined, the discovery feature "Available FS2s—Click to Refresh" on the *Network* web page will not work correctly and list other FS2s on the network.

Variable	Enter a default gateway or router address. This is only needed for Static IP configurations. The factory <i>Default Gateway</i> is 192.168.0.1. If <i>IP Address Type</i> is set to <i>DHCP</i> , the Default Gateway is set by the DHCP server and cannot be changed by the user.
----------	---

Alarm Configuration Screen

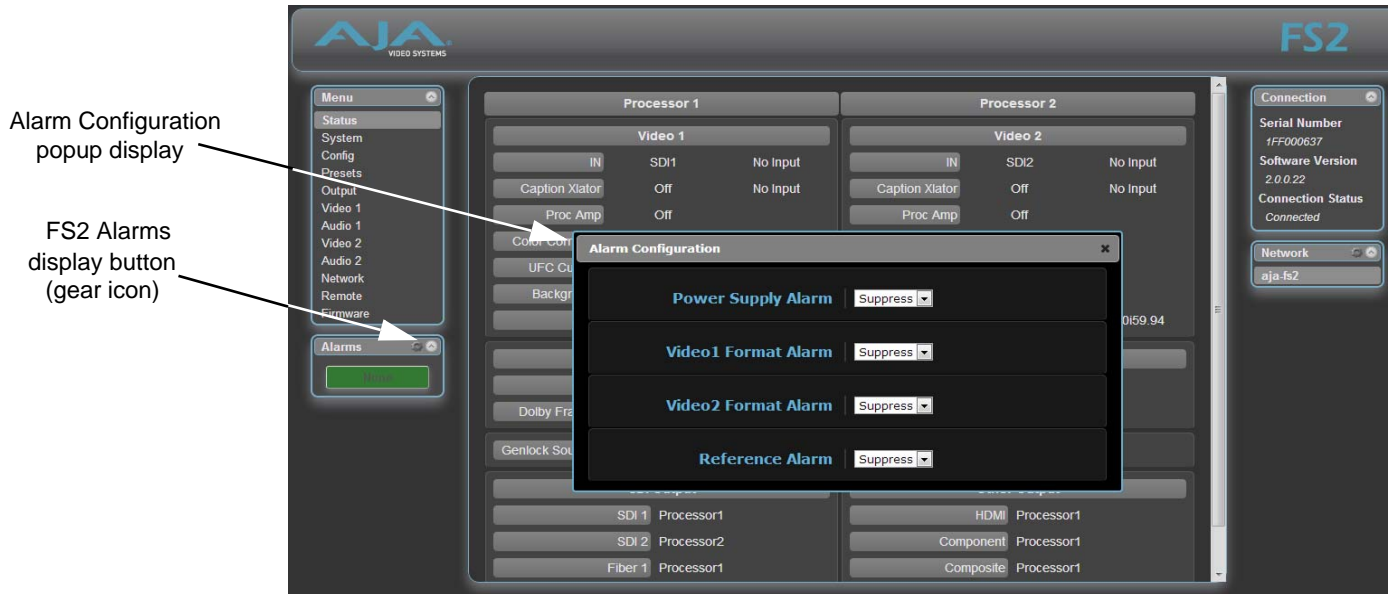

You can pop open the *Alarm Configuration* display at any time and on any screen by clicking the display button in the upper right corner of the *Alarms* panel.

To close the window, press the ESC key, or click the X in the upper right corner.

The *Alarm Configuration* display provides control over these alarm settings:

- Power Supply Alarm (see [“5 Power Supply Alarm” on page 51](#))
- Video 1 and Video 2 Format Alarm (see [“6.1 Vid1 Format Alarm” on page 51](#))
- Reference Alarm (see [“7 Reference Alarm” on page 51](#))

Status Screen



The Status screen displays overall FS2 operational status. You can right-click most values to change them, allowing you to edit many parameters in one place. Parameters with format incompatibilities or other alarms are highlighted in red.

Processor 1 Video 1	IN Captioning Proc Amp Color Corrector UFC Custom Background OUT	Shows the input source and format for Video Processor 1. Shows the caption selection and caption signal presence. Shows whether the Proc Amp is On or Off. Shows whether the Color Corrector (RGB) is On or Off. Shows whether Custom conversion, AFD, and ROI are On or Off. Shows the source and format of Background video. Shows the output video selection and format for Video Proc 1.
Processor 1 Audio 1	IN Dolby Framer	Shows the audio input feeding Audio Processor 1. Shows if Dolby E Framer is On and locked to video.
Processor 2 Video 2	IN Captioning Proc Amp Color Corrector UFC Custom Background OUT	Shows the input source and format for Video Processor 2. Shows the captioning selection and signal presence. Shows whether the Proc Amp is On or Off. Shows whether the Color Corrector (RGB) is On or Off. Shows whether Custom conversion, AFD, and ROI are On or Off. Shows the source and format of Background video. Shows the output video selection and format for Video Proc 2.
Processor 2 Audio 2	IN Dolby Framer	Shows the audio input feeding Audio Processor 2. Shows if Dolby E Framer is On and locked to video.
Genlock Source	Reference	Shows the input providing the genlock reference.
SDI Output	SDI 1 SDI 2 Fiber 1 Fiber 2	Shows the source of the SDI 1 output. Shows the source of the SDI 2 output. Shows the source of the Fiber 1 output. Shows the source of the Fiber 2 output.
Other Output	HDMI Component Composite	Shows the source of the HDMI output. Shows the source of the Component video output. Shows the source of the Composite video output.

System Screen

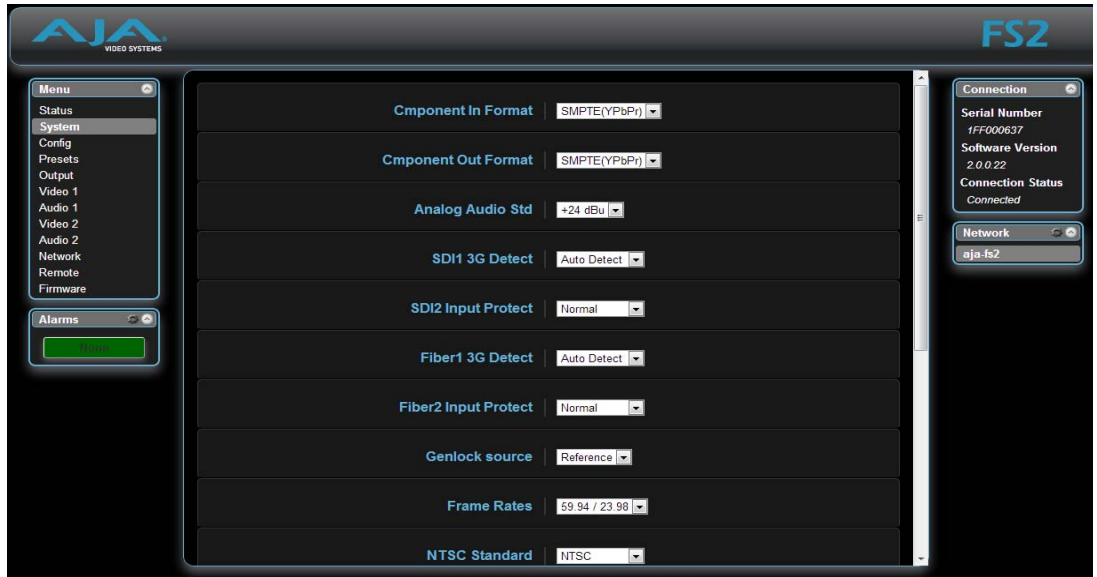

The *SYSTEM* web interface screen includes parameters for setting up various FS2 system related features (video formats, audio level standards, etc.).

The *System* screen parameters are identical to those available on the FS2 front panel. These include:

- Component In Format (see [“1 Component In Format” on page 53](#))
- Component Out Format (see [“2 Component Out Format” on page 54](#))
- Analog Audio Std (see [“3 Analog Audio Std” on page 54](#))
- SDI1 3G Detect (see [“4 SDI1 3G Detect” on page 54](#))
- SDI2 Input Protect (see [“5 SDI2 Input Protect” on page 55](#))
- Fiber1 3G Detect (see [“6 Fiber1 3G Detect” on page 56](#))
- Fiber2 Input Protect (see [“7 Fiber2 Input Protect” on page 56](#))
- Genlock Source (see [“8 Genlock Source” on page 56](#))
- Frame Rates (see [“9 Frame Rates” on page 56](#))
- NTSC Standard (see [“10 NTSC Standard” on page 57](#))
- Composite Downconv (see [“11 Composite Downconv” on page 57](#))
- HDMI RGB Range (see [“12 HDMI RGB Range” on page 57](#))
- AES/EBU SRC Mode (see [“14.0 AES/EBU SRC Mode” on page 57](#))
- AES/EBU SRC (see [“14.1–14.8 AES/EBU SRC” on page 58](#))
- Dolby Decoder Input (see [“15 Dolby Decoder Input” on page 59](#))
- Dolby Decoder Mode (see [“16 Dolby Decoder Mode” on page 59](#))
- Dolby Decoder Aux Out (see [“17 Dolby Decoder Aux Out” on page 59](#))
- Dolby Decoder Aux Mode (see [“18 Dolby Decoder Aux Mode” on page 60](#))

Config Screen

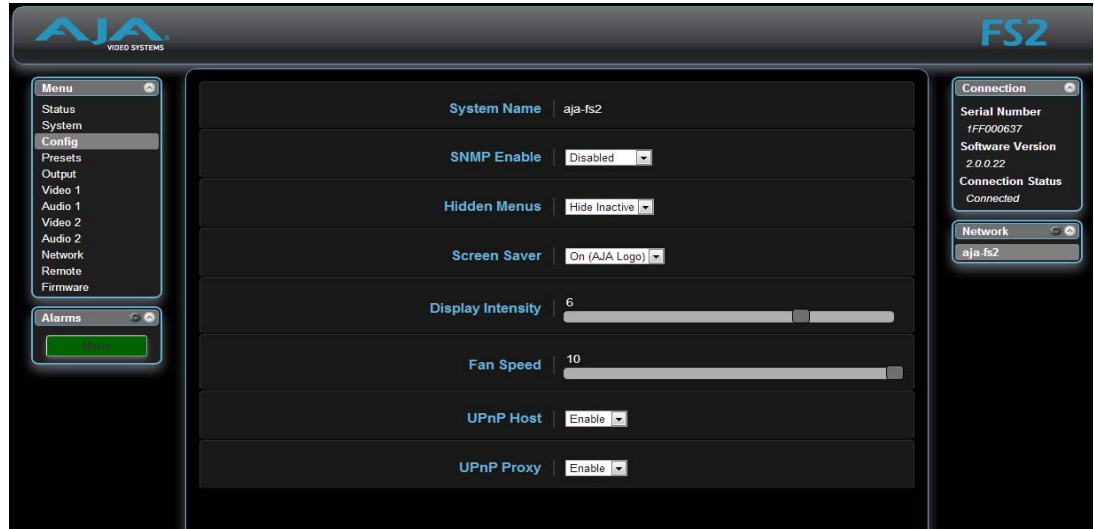

The *Config* screen includes functions to name the FS2, configure SNMP, hide or show unused menus, and change the front panel display brightness and FS2 fan speed, and configure UPnP.

System Name

The System Name parameter sets the name of the FS2 system. To change the System Name, click on and drag the cursor across the displayed name, and type in a new name.

Variable	Highlight the existing name and type in a new name, up to 20 characters. Allowed characters are A-Z, a-z, numerals, hyphen, and period.
----------	---

SNMP Parameters

The following parameters are used to setup the FS2 SNMP (Small Network Management Protocol) feature.

- SNMP Enable
- SNMP Trap Dest 1
- SNMP Trap Port 1
- SNMP Trap Dest 2
- SNMP Trap Port 2

In addition, the following alarms may affect SNMP messages:

- Power Supply Alarm
- Video1 Format Alarm
- Video 2 Format Alarm
- Reference Alarm

Refer to "[Chapter 6: SNMP on page 101](#)" for a description of SNMP and how the FS2 supports it.

Hidden Menus

This selection lets you choose whether to hide or show inactive menus.

Hide Inactive (default) Show All	Hides menus that are not in use. Shows all menus, even those that are not in use.
-------------------------------------	--

Display Intensity

Display Intensity determines alphanumeric display and front panel LED brightness.

Variable	Use the slider to dim or brighten the alphanumeric display and activity indicator LEDs in steps from 1 (dim) to 8 (brightest). Default is 6
----------	--

UPnP Host

UPnP Host enables the FS2 to be discovered by a Windows network.

Enable (default) Disable	Enables the FS2 to be discovered by a Windows network. Disables Windows network discovery of the FS2.
-----------------------------	--

When this parameter is enabled, you can view the FS2 on a Windows Network by clicking these selections in Windows 7: *Start > Computer > Network* (in left pane). Any FS2s on the network will be listed under *Other Devices* below *Computers* and *Media Devices*. If your system does not have network discovery enabled, you may need to enable it following the Windows help instructions to make network devices visible in the Windows Network window.

UPnP Proxy

UPnP Proxy enables the FS2 to serve as a proxy for other AJA devices, allowing them to be discovered on a Windows network through the FS2. When enabled, the FS2 acts as a proxy for all the AJA devices that it is able to connect to that have not already been discovered on the network. The devices will be listed in the FS2 Network window. Once the devices appear on the network, they can connect directly to other devices and computers without involving the FS2.

Enable (default) Disable	Enables the FS2 to connect other AJA devices to the network. Disables the FS2 from serving as a proxy for AJA devices.
-----------------------------	---

Presets Screen

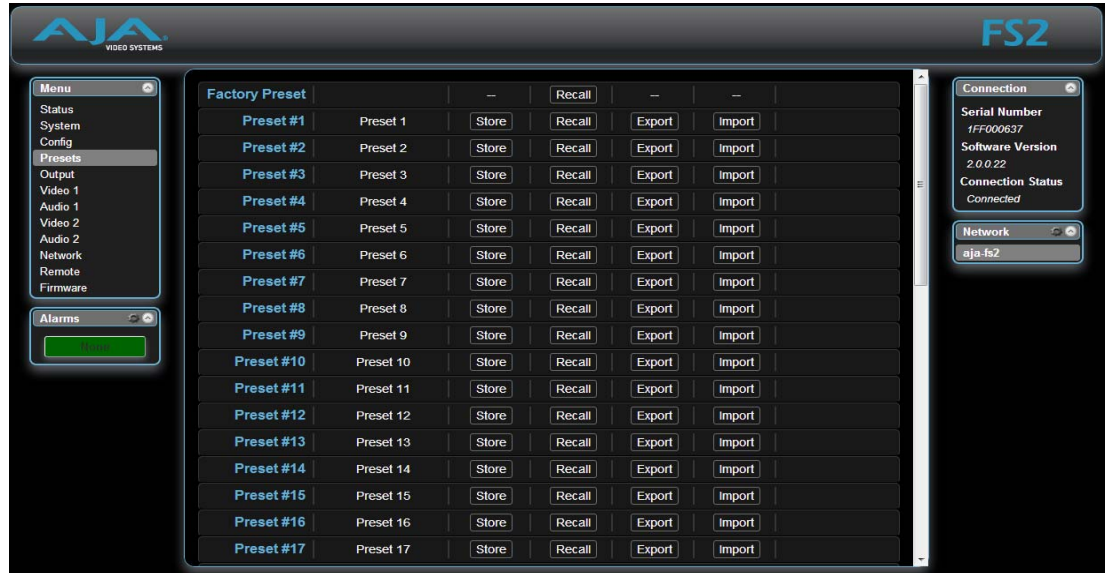

The *Presets* screen allows you to save FS2 Preset Configurations into 40 separate memory registers and recall the presets whenever needed. This screen also includes Export and Import functions that allow exporting one or all FS2 presets to your computer as files and importing exported preset files from your computer. A displayed message indicates successful or failed saves, recalls, exports, and imports.

Presets Screen Controls

Factory Preset *Factory Preset* recalls all editable video and audio parameters to their factory default settings. Individual presets, user preferences, and Network settings, such as the IP Address, are not affected.

Recall The *Recall* buttons recall saved FS2 preset configurations.

	<p>Caution!</p> <p>When you recall a Preset Configuration, the recalled preset immediately replaces the system's existing configuration. All previous settings are lost unless you have previously stored them in another preset configuration or an exported file.</p>
---	--

Store The *Store* buttons let you save the current FS2 configuration into the preset register with the associated name and number. A preset is a set of all System, Video, Audio, and Output parameters as they were set at the time the preset was stored. Only editable parameters are saved in the presets. Non-editable parameters are **not** saved.

To change a preset name, click in the name's text field and type a new name.

Export The *Export* buttons save the associated preset contents to a file on your computer. The file gets exported to the default download location specified in your browser options. The file name is the same as the preset name with the suffix *.presets*. If you export multiple files for the same preset, a number gets appended to ensure a unique file name. The file size is small, usually less than 100 kilobytes.

Import The *Import* buttons let you browse for and import a preset file on your computer into the preset register associated with the selected button. A dialog box warns you that the operation will overwrite the current preset contents with the file contents.

Export Presets 1–40 (All) *Export All* lets you save the contents of all presets to a file on your computer. The file gets exported to the default download location specified in your browser options with the name *all.presets*. If you export multiple files, a number gets appended to ensure a unique file name.

Import Presets 1–40 (All) *Import All* lets you browse for and import a previously exported *all.presets* file from your computer. A dialog box warns you that the operation will overwrite all 40 current preset contents with the contents stored in the file.

Interaction of Presets and GPIs

Triggering presets using GPI inputs offers considerable power but also requires some care to avoid unexpected results. If you plan to trigger presets using GPIs, please see the information about the [“Interaction of Presets and GPIs” on page 48](#).

Output Screen

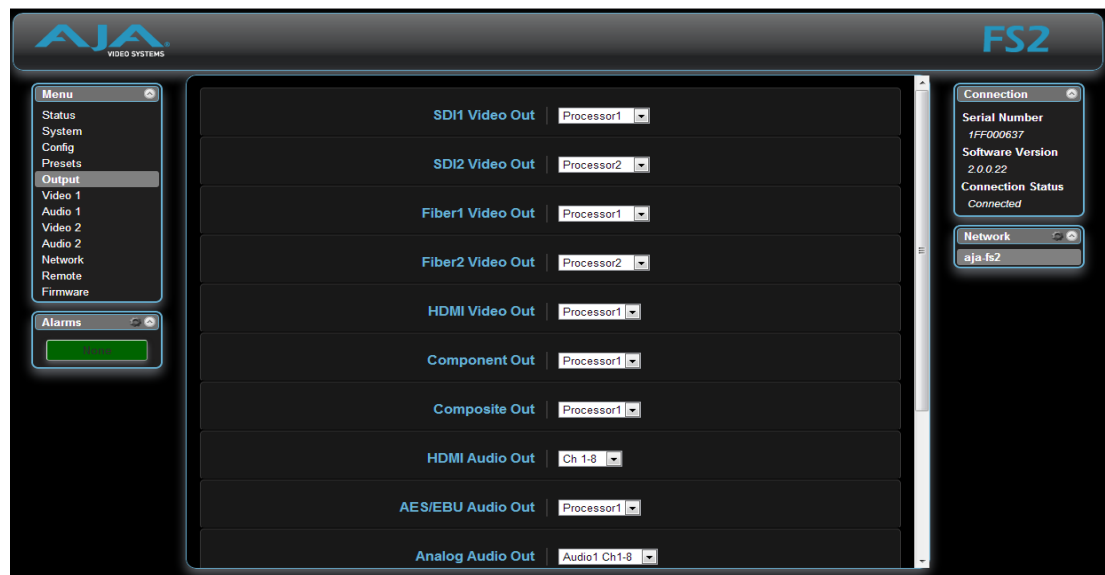

The Output screen selects the video and audio outputs that are routed to the FS2 rear panel.

The parameters available on the Output browser screen are identical to the front panel display menus. Complete descriptions of these parameters are accessible using the following cross references:

- SDI1 Video Output (see [“1.1 SDI1 Video Out” on page 60](#))
- SDI2 Video Out (see [“1.2 SDI2 Video Out” on page 60](#))
- Fiber1 Video Out (see [“2.1 Fiber1 Video Out” on page 61](#))
- Fiber2 Video Out (see [“2.2 Fiber2 Video Out” on page 61](#))
- HDMI Video Out (see [“3 HDMI Video Out” on page 61](#))
- Component Out (see [“4 Component Out” on page 61](#))
- Composite Out (see [“5 Composite Out” on page 61](#))
- HDMI Audio Out4 (see [“6 HDMI Audio Out” on page 61](#))
- AES/EBU Audio Out (see [“7 AES/EBU Audio Out” on page 61](#))
- Analog Audio Out (see [“8 Analog Audio Out” on page 62](#))
- SDI1 3G Config (see [“9.1 SDI1 3G Config” on page 62](#))
- SDI2 3G Config (see [“9.2 SDI2 3G Config” on page 62](#))
- Fiber1 3G Config (see [“10.1 Fiber1 3G Config” on page 62](#))
- Fiber2 3G Config (see [“10.2 Fiber2 3G Config” on page 62](#))

Video 1 & 2 Screens

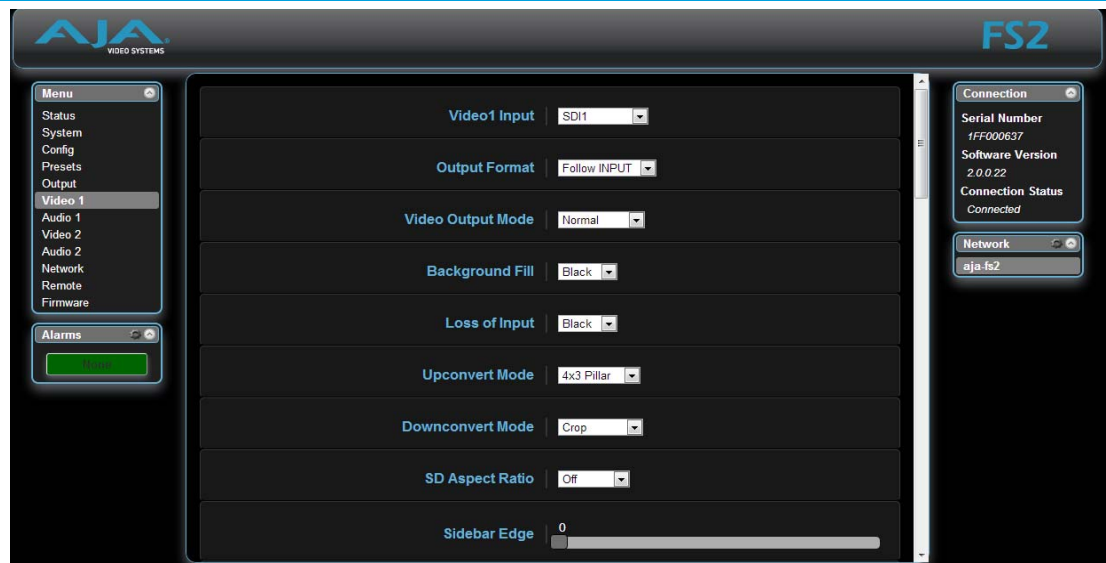

The Video 1 and 2 screens select the video and audio outputs that are routed to the FS2 rear panel, and controls the FS2's video signal processing.

The parameters available on the Video 1 and 2 browser screens are identical to the front panel display menus. Complete descriptions of these parameters are accessible using the following cross references:

- Video Input (see [“1 Video Input” on page 63](#))
- Output Format (see [“2 Output Format” on page 63](#))
- Video Output Mode (see [“3 Video Output Mode” on page 64](#))
- Background Fill (see [“4 Background Fill” on page 64](#))

- Loss of Input (see [“5 Loss of Input” on page 64](#))
- Upconvert Mode [“6 Upconvert Mode” on page 64](#))
- Downconvert Mode (see [“7 Downconvert Mode” on page 65](#))
- SD Aspect Ratio (see [“8 SD Aspect Ratio Convert” on page 67](#))
- Sidebar Edge (see [“9 Sidebar Edge” on page 68](#))
- Matte Luma, Chroma, and Hue controls (see [“Matte of Background Fill” on page 69](#))
- Proc Amp controls (see [“Proc Amp Controls \(YUV\)” on page 69](#))
- Color Corrector controls (see [“Color Corrector \(RGB\)” on page 70](#))
- Custom Size/Pos controls (see [“Custom Conversion Settings” on page 70](#))
- Region of Interest controls (see [“Region of Interest \(ROI\)” on page 72](#))
- Output Timing and Extra Frame Delay controls (see [“Timing and Delay” on page 73](#))
- Video Legalizer controls (see [“Video Legalizer” on page 73](#))
- AFD controls (see [“AFD” on page 74](#))
- Caption Xlator (see [“18 Caption Xlator” on page 75](#))
- Input Scan Format (see [“19 Input Scan Format” on page 76](#))
- SD Line 21 Blanking (see [“20 SD Line 21 Blanking” on page 76](#))
- Test Pattern Video (see [“21 Test Pattern Video” on page 77](#))
- Freeze Output (see [“22 Freeze Output” on page 77](#))

Audio 1 and 2 Screens

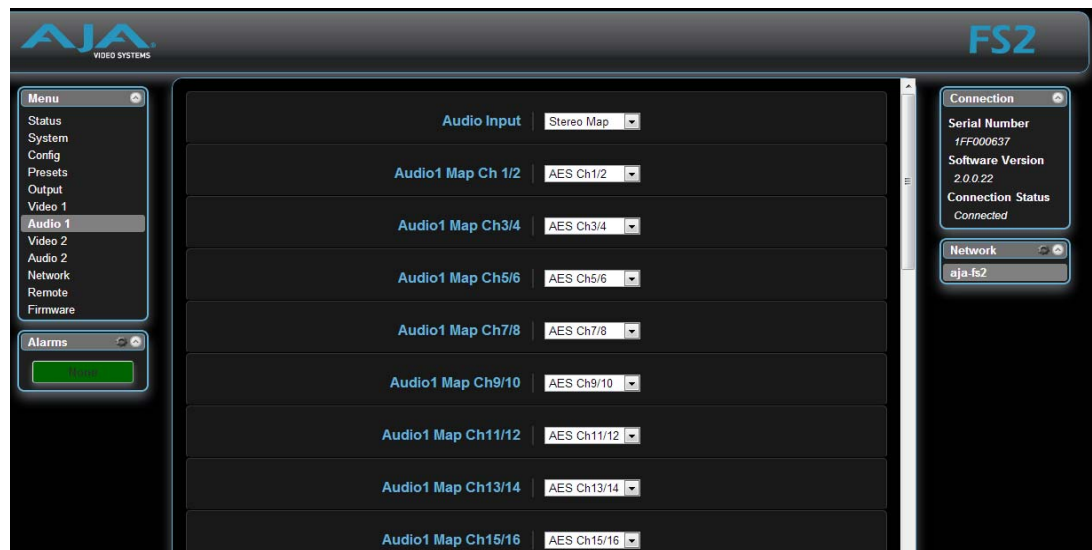

The *Audio 1* and *Audio 2* browser screens display the audio control selections for the audio inputs and outputs, for control of the FS2's audio routing and signal processing.

The parameters available on the Audio 1 and 2 browser screens are identical to the front panel display menus. Complete descriptions of these parameters are accessible using the following cross references:

- Audio Input (see [“1.0 Audio Input” on page 78](#))
- Audio Map Ch1–16 (see [“1.1–1.16 Audio Map Ch1–16” on page 79](#))
- Audio Map Ch 1/2–15/16 (see [“1.17–1.24 Audio Map Ch 1/2–15/16” on page 80](#))

- Embedded Audio Out (see [“2 Embedded Audio Out” on page 80](#))
- Audio Follow Video (see [“3 Audio Follow Video” on page 80](#))
- Audio Signal Gen (see [“4 Audio Signal Gen” on page 81](#))
- Audio Delay (mS) (see [“Audio Delay Controls” on page 81](#))
- Audio Out Levels (see [“Audio Output Level Controls” on page 82](#))
- Audio Out Phase (see [“Audio Output Phase Controls” on page 83](#))
- Dolby Framer (see [“Dolby Framer Controls” on page 83](#))

Remote Screen

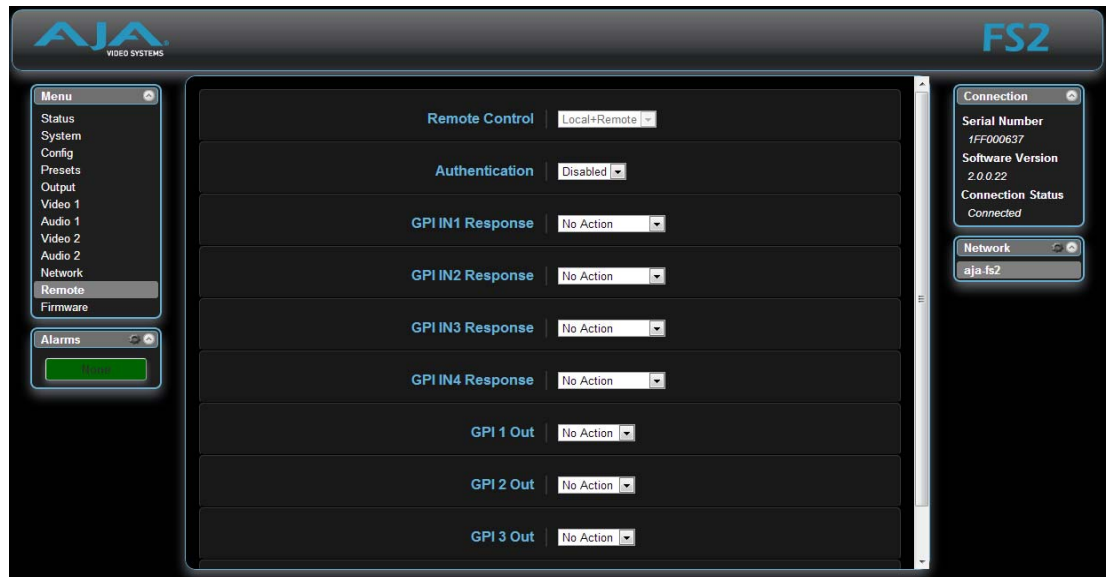

The *REMOTE* screen contains parameters that affect how the FS2 is controlled. Control options include the front panel, a remote computer running a browser, and GPI inputs and outputs.

NOTE: *The Remote Menu Group parameters available on the front panel interact with the browser parameters available on an attached computer, and vice versa. For example, the Remote Control parameter can only be changed from the front panel, and when set to Local Only will deactivate all browser remote control parameters.*

See [“REMOTE Menu Group” on page 46](#) for detailed information about FS2 remote control options.

Firmware Screen

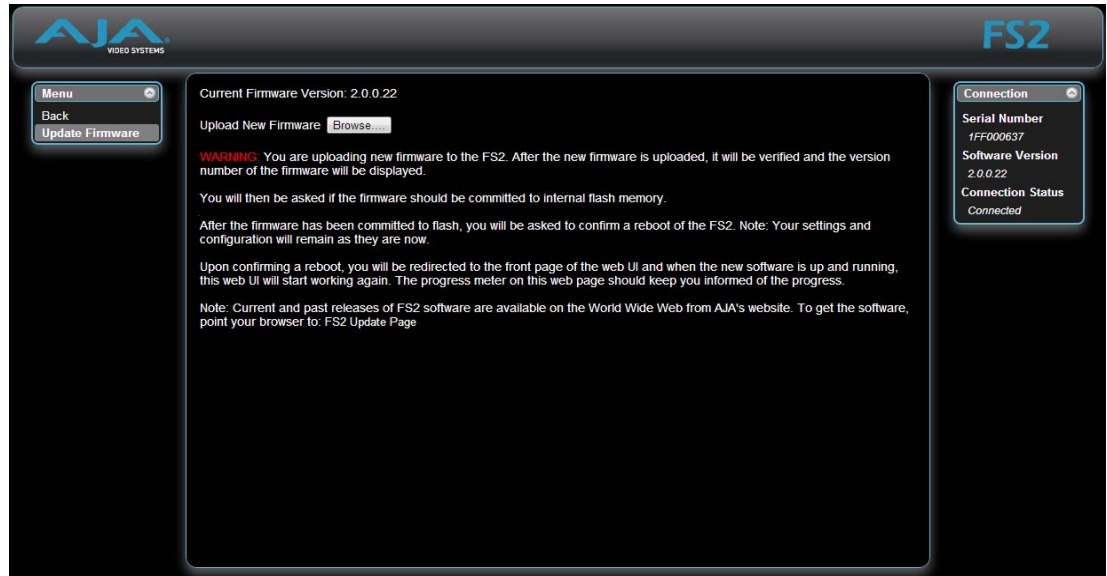

The *Update Firmware* screen allows you to download and install a firmware update from AJA.

First visit the AJA website (aja.com) to locate and download the updated software. The following page provides FS2 support information and will include links to locations where you can download updates:

<http://www.aja.com/en/products/fs2/#support>

After downloading the software update to your local drive, use the *Browse* button shown below to locate the local software copy. Follow the prompts to load the new firmware into the FS2. See "[Software Update Installation](#)" on page 33 for more information.

Chapter 6: SNMP

FS2 Simple Network Management Protocol

SNMP is defined as a “simple network management protocol” and was specified as a component of the internet protocol suite by the Internet Engineering Task Force (IETF). The FS2 can act as a *network element* that issues SNMP trap messages signaling a detected alarm condition or other system condition. A device’s trap messages are defined in an MIB (Management Information Base) file. The trap messages are sent to a server-based external NMS destination. For example, the FS2 could send a trap message if one of its redundant power supplies becomes unplugged. A client software agent that communicates with the NMS might then get a message telling the operator what has happened.

The FS2 must be configured for SNMP messaging. By default SNMP is disabled on the FS2. Besides activating SNMP, trap destinations must also be defined with fixed IP addresses.

When SNMP is enabled, one or more of these alarms may be sent by the FS2 to the client network management system (NMS) as a trap message:

- fs2PowerSupplyAlarm (PS1 Alarm)
- fs2 PowerSupply2Alarm (PS2 Alarm)
- fs2ReferenceAlarm (Ref Video Alarm)
- fs2Vid1ReferenceAlarm (Vid1 Ref Video Alarm)
- fs2Vid2ReferenceAlarm (Vid2 Ref Video Alarm)
- fs2Vid1FormatAlarm (Vid1 Format Alarm)
- fs2Vid1BackgroundAlarm (Vid1 Background Format Alarm)
- fs2Vid2FormatAlarm (Vid2 Format Alarm)
- fs2Vid2BackgroundAlarm (Vid2 Background Format Alarm)
- fs2OverTemperatureAlarm (FS2 Over Temperature Alarm)

SNMP Configuration

FS2 SNMP configuration can be accomplished using the front panel or with the web browser computer interface (if Remote Control is enabled).

Front Panel Screens

The FS2 front panel screens for SNMP are accessible through the CONFIG button. The direct SNMP configuration screens are:

- 4.0 SNMP Enable
- 4.1 SNMP Trap Destination 1
- 4.2 SNMP Trap Port 1
- 4.3 SNMP Trap Destination 2
- 4.4 SNMP Trap Port 2

These SNMP direct configuration parameters are described later in this chapter.

In addition, the following front panel CONFIG screens can affect SNMP alarm messaging:

- 5.0 Power Supply Alarm (see [page 51](#)).
- 6.1 & 6.2 Video Format Alarm (see [page 51](#)).
- 7 Reference Alarm (see [page 51](#)).

Front Panel Octet Value Entry Procedure

Set the octets (numbers between periods) values as follows:

1. Push *ADJUST* momentarily to enter edit mode.
2. Turn *SELECT* to select the octet you want to edit, indicated by blinking.
3. Turn *ADJUST* to enter the new value.
 - If you need to revert to the previous setting (undo changes), push *SELECT*.
4. Push *ADJUST* momentarily to save and activate the new setting.
 - If you want to revert to the default value, hold down *ADJUST* for 4 seconds.

Web Browser

SNMP direct configuration settings are available on the Config screen of the web browser interface.

Figure 12. Web Browser Config Screen SNMP Parameters

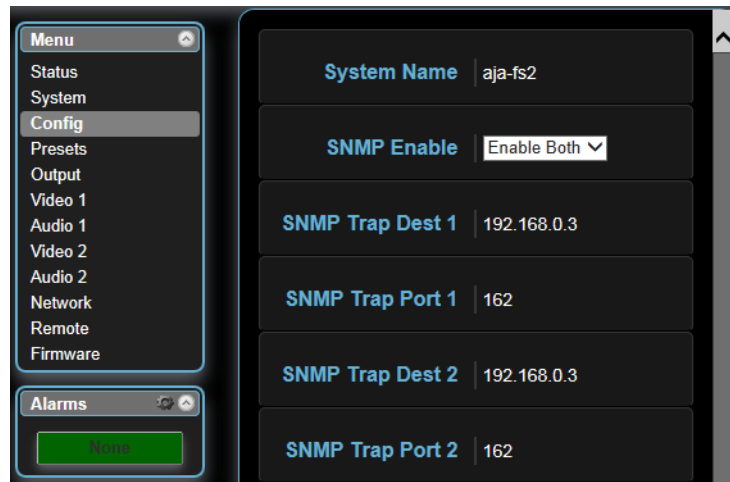

Clicking on the Alarms gear icon opens a window that permits setting alarm messaging.

Figure 13. Web Browser Alarm Configuration Window

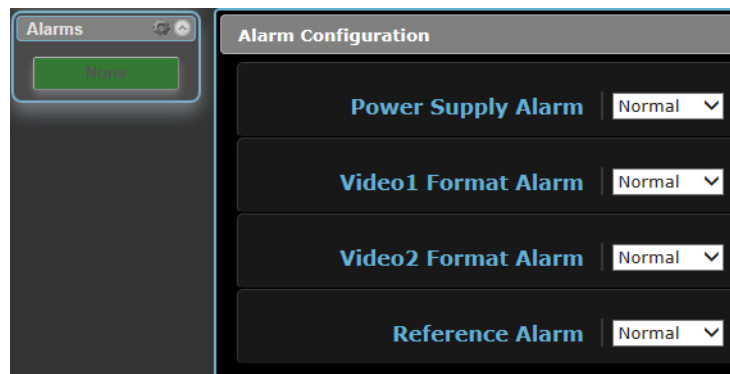

SNMP Configuration Parameters

4.0 SNMP Enable

The *SNMP Enable* parameter turns ON and OFF all SNMP messaging between the FS2 and an external client.

Disable (<i>default</i>)	When set to <i>Disable</i> , the FS2 will not issue SNMP trap messages.
Enable 1	When set to <i>Enable 1</i> , the FS2 issues SNMP trap messages to Trap Destination 1 (parameter 4.1) and as defined in the MIB.
Enable Both	When set to <i>Enable Both</i> , the FS2 issues SNMP trap messages to Trap Destination 1 and 2 (parameters 4.1 and 4.3) and as defined in the MIB.

4.1 SNMP Trap Destination 1

This parameter determines the *SNMP Trap Destination* IP address where trap messages issued by the FS2 will be sent. This parameter is available only if parameter 4.0 *SNMP Enable* is set to *On*.

IP Address	Set the desired IP address where traps will be sent (usually a client on your LAN). <i>Default: 192.168.0.3</i>
------------	---

4.2 SNMP Trap Port 1

This parameter determines the *SNMP Trap Port 1* used for sending destination #1 trap messages. UDP Port 162 is the default used for SNMP trap messages. However, if this port is being used by another protocol or service, you can change the setting by modifying this parameter. This parameter is available only if parameter 4.0 *SNMP Enable* is set to *On*.

Variable	Select a UDP port for sending FS2 trap messages. <i>Default: 162</i>
----------	--

NOTE: The *SNMP Trap Port* number does not blink when changed (as does the *Trap Destination IP address*); if you change the port number and exit the parameter, the port changes immediately to the new value.

4.3 SNMP Trap Destination 2

This parameter determines the secondary *SNMP Trap Destination* IP address where trap messages issued by the FS2 will be sent (if desired). This parameter is similar to 4.1 *Trap Destination 1* above. Default is 192.168.0.3

4.4 SNMP Trap Port 2

This parameter determines the *SNMP Trap Port* used for sending destination #2 trap messages, similar to 4.2 *SNMP Trap Port 1* above. Default is 162.

If you need to revert to the previous setting (undo changes), push *SELECT*. If you want to revert to the default value, hold down *ADJUST* for 4 seconds.

Appendix A: Specifications

Video Format Conversion

The FS2 can convert almost any input format to nearly any output format, as long as the frame rates are of the same family. The three families are:

- 59.94/29.97/23.98
- 50/25
- 60/30/24

Available input and output formats are listed later in this appendix.

Conversion Exceptions

- The following frame rates are not supported for input or output:
 - 720p23.98/24/25/29.97/30.
- The FS2 cannot convert a 29.97 or 59.97 input to 23.98 Hz.
- The FS2 cannot convert a 30 Hz or 60 Hz input to 24 Hz.
- Outputs of 23.98 or 24 Hz can be derived only from 23.98 or 24 Hz inputs.
- Component I/O does not support 1080p.
- The FS2 does not support reverse 3:2 pulldown.
- The FS2 does not accept or produce 4:4:4 YCbCr, RGB, or XYZ inputs or outputs.
- The FS2 does not accept or produce YCbCr 4:2:2 12-bit inputs or outputs.
- The FS2 does not support embedded audio output for the following formats:
 - 2K1080p 29.97 or 2K1080p 30
 - 2K1080p 59.94 or 2K1080p 60 when 3G Config is set to 3 Gb Level B or 1.5 Gb DualLink.
- The FS2 does not convert NTSC to PAL-M, or vice versa.

Video Format Alarms

When incompatible I/O formats are detected, an alarm can be triggered with these results:

- Lights the relevant alarm LED on the front panel (FMT ERROR, 1 or 2).
- Displays an alarm in the browser user interface.
- Influences selection of the first-displayed status screen.
- Generates an SNMP trap (if configured).
- Triggers a GPI Output (if configured).

Video Input/Output Formats

SDI and Fiber

The FS2 has two standard SDI video inputs and outputs, and two optional Fiber video inputs and outputs.

All SDI video inputs and outputs, including Fiber, are YCbCr 4:2:2 pixel format.

SD-SDI, 270Mb (SMPTE 259)

- 525i/59.94
- 625i/50

- HD-SDI, 1.4835Gb (SMPTE 292)**
 - 720p/59.94
 - 1080i/59.94
 - 1080PsF/23.98, 1080PsF/29.97
 - 1080p/23.98, 1080p/29.97
 - 2Kx1080p/23.98, 2Kx1080p/29.97

- HD-SDI, 1.485 Gb (SMPTE 292)**
 - 720p/50, 720p/60
 - 1080i/60
 - 1080PsF/24, 1080PsF/25, 1080PsF/30
 - 1080p/24, 1080p/25, 1080p/30
 - 2Kx1080p/24, 2Kx1080p/25, 2Kx1080p/30

- Dual-link HD-SDI, 2x 1.4835Gb (SMPTE 372)**
 - 1080p/59.94
 - 2Kx1080p/59.94

- Dual-link HD-SDI, 2x 1.485Gb (SMPTE 372)**
 - 1080p/50, 1080p/60
 - 2Kx1080p/50, 2Kx1080p/60

- 3G HD-SDI, 2.967Gb (SMPTE 425)**
 - 1080p/59.94 (Level A or B)
 - 2Kx1080p/59.94 (Level A or B)
 - Dual Stream (2 streams 1.4835Gb HD-SDI)

- 3G HD-SDI, 2.97Gb (SMPTE 425)**
 - 1080p/50, 1080p/60 (Level A or B)
 - 2Kx1080p/50, 2Kx1080p/60 (Level A or B)
 - Dual Stream (2 streams 1.485Gb HD-SDI)

HDMI

The HDMI input automatically accepts RGB 4:2:2 or YCbCr 4:2:2. HDMI outputs are configurable between RGB and YUV. HDCP copy protected video is not supported.

- 525i/59.94
- 625i/50
- 720p/50, 720p/59.94, 720p/60
- 1080i/59.94, 1080i/50
- 1080p/23.98, 1080p/29.97, 1080p/59.94, 1080p/24, 1080p/25, 1080p/30, 1080p/50, 1080p/60

Component Analog

The Component Analog Input accepts YUV, configurable to SMPTE or Betacam levels. The Component Analog Output is configurable to YUV (Betacam or SMPTE), or RGB.

- 525i/59.94
- 625i/50
- 720p/50, 720p/59.94, 720p/60
- 1080i/59.94
- 1080PsF/23.98, 1080PsF/29.97
- 1080p/23.98, 1080p/29.97
- 1080PsF/24, 1080PsF/25, 1080PsF/30 (SMPTE 274)
- Output only: 1080p/24, 1080p/25, 1080p/30 (SMPTE 274)

Composite Analog

- The FS2 composite analog video input/output formats are:
- 525i/59.94 (switchable NTSC 7.5 IRE, NTSC 0 IRE, or PAL-M)
 - 625i/50

Reference

- 525i/59.94 analog composite
- 625i/50 analog composite
- Tri-level sync

Computer (VESA) Formats

- The FS2 accepts these computer (VESA) video formats:
- 640x480 (VGA) - 60 Hz
 - 800x600 (SVGA) - 60 Hz
 - 1024x768 (XGA) - 60 Hz
 - 1152x864 - 75 Hz
 - 1280x768 (WXGA) - 60 Hz
 - 1280x960 - 60 Hz
 - 1280x1024 (SXGA) - 60 Hz
 - 1600x1200 (UXGA) - 60 Hz
 - 1680x1050 (WSXGA+) - 60 Hz
 - 1920x1200 (WUXGA) - 60 Hz

Video A/D, D/A Converters

- 12 bits
- 2x oversampled (HD)
- 4x oversampled (SD)

Audio

- Inputs and Outputs**
- 8-channel balanced analog I/O, DB-25F 25-pin connector (Tascam pinout)
 - 16-channel AES/EBU I/O (BNC), DB-25F 25-pin connector
 - 16-channel SDI/HD-SDI embedded

- Audio Levels** Audio levels can be set to:
- +12dBu, +15dBu, +18dBu, +24dBu, (Full Scale Digital)

Interfaces

- LAN**
- 10/100/1000 automatic configuration
 - Automatic cable crossover (auto MDI-X)
 - Embedded web server
 - SNMP
 - VTECS™ protocol for Remote Control Panel

RS-422 • DB-15F: Reserved for future use.

GPI • DB-15F: single connector provides four inputs and four outputs. See Appendix B for a connector pinout and GPI specifications.

Physical

Dimensions

- Width: 17.5 inches (44.45cm); 19 inches (48.26 cm) including rack ears
- Depth: 16 inches (40.65 cm), including knobs and connectors that extend beyond the frame
- Height: 1RU, 1.75 inches (4.44cm)

Weight • 7.85 pounds, 3.56 kilograms

Temperature

- Operating temperature range: 0–40 degrees C
- Cooled via two internal fans and side vents.

Power

- Voltage: 100-240 VAC
- Power Consumption: 55W (80W maximum)
- Two independent power supplies, fully redundant, diode isolated.

Appendix B: FS2 Pinouts

GPI Pinouts

Figure 14. GPI DE-15F Connector Pinout

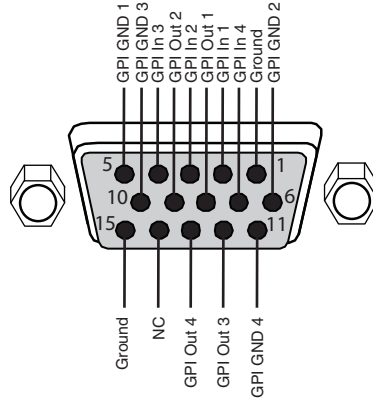

Pin	Function	Pin	Function
1	Ground	9	GPI Out 2
2	GPI In 1	10	GPI GND 3
3	GPI In 2	11	GPI GND 4
4	GPI In 3	12	GPI Out 3
5	GPI GND 1	13	GPI Out 4
6	GPI GND 2	14	NC
7	GPI In 4	15	Ground
8	GPI Out 1		

The GPI inputs and outputs are electrically isolated from power and ground on the FS2 frame. There are four inputs and four outputs. Electrical isolation is provided for up to four pieces of external equipment.

The following guidelines apply to the four GPI inputs and outputs:

- GPI In 1 and GPI Out 1 share a common isolated ground on pin 5 (GPI GND 1),
- GPI In 2 and GPI Out 2 share a common isolated ground on pin 6(GPI GND 2).
- GPI In 3 and GPI Out 3 share a common isolated ground on pin 10(GPI GND 3).
- GPI In 4 and GPI Out 4 share a common isolated ground on pin 11 (GPI GND 4).
- Pins 1 and 15, local chassis ground, may only be used as references when isolation is not required.
- All four GPI inputs are internally pulled high through a 10K ohm resistor to an isolated +5V supply, so that a relay contact closure or any device sinking at least 0.4 mA to ground will register a logic low.
- All four GPI outputs are +5V TTL compatible, sourcing up to 6mA and sinking up to 4mA each.
- GPI Inputs light the front panel EXT LED when triggered.

The following illustration shows typical external wiring to the GPI connector. The GPI inputs require some kind of contact closure between the input pin and the input ground pin to register the logic low that triggers the GPI input.

You can connect the outputs to TTL buffers that communicate the GPI output logic levels to other devices. For example, you could use an opto-isolator controlling a relay to activate other equipment as shown below.

Figure 15. Typical GPI Input and Output Connections

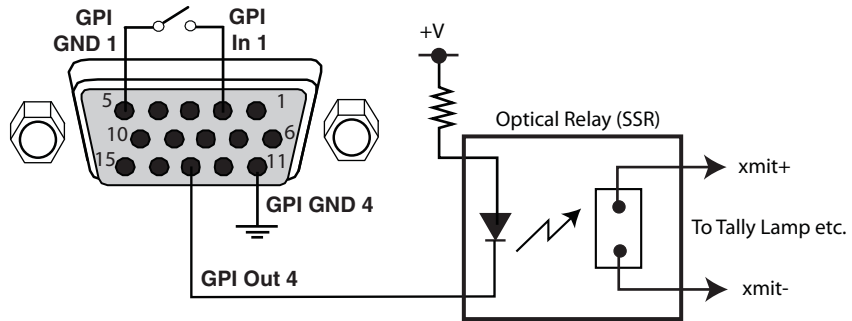

Audio Connection Pinouts

Analog Audio

Figure 16. Audio Connector Pinout

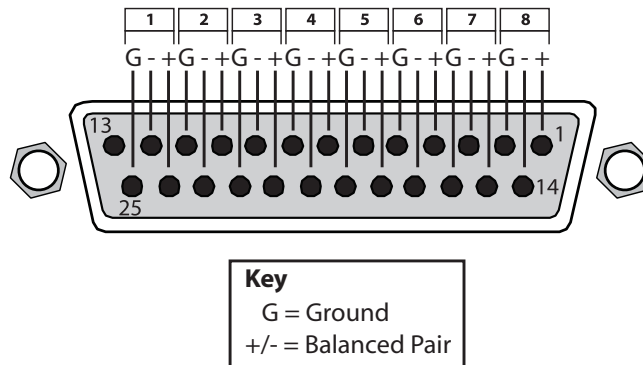

The two DB25 connectors on the FS2 rear panel support a TASCAM-style cable snake for balanced 8-channel analog audio. The pinout is the same for both input and output connectors, each following the TASCAM DB-25 standard shown in the drawing above. The top connector is for analog audio inputs 1-8, and the bottom connector is for analog audio outputs 1-8

Digital Audio

The same pinout scheme as above is used for the AES/EBU digital audio connections, except each channel handles a pair of digital audio signals (16 total per connector). The top connector is for digital audio input channels 1-16, and the bottom connector is for digital audio output channels 1-16.

Appendix C: Safety & Compliance

Federal Communications Commission (FCC) Compliance Notices

Class B Interference Statement

This equipment has been tested and found to comply with the limits for a Class B digital device, pursuant to Part 15, Subpart B of the FCC Rules. These limits are designed to provide reasonable protection against harmful interference in a residential installation. This equipment generates, uses, and can radiate radio frequency energy and, if not installed and used in accordance with the instructions, may cause harmful interference to radio communications. However, there is no guarantee that interference will not occur in a particular installation. If this equipment does cause harmful interference to radio or television reception, which can be determined by turning the equipment off and on, the user is encouraged to try to correct the interference by one or more of the following measures:

- Reorient or relocate the receiving antenna.
- Increase the separation between the equipment and receiver.
- Connect the equipment into an outlet on a circuit different from that to which the receiver is connected.
- Consult the dealer or an experienced radio/TV technician for help.

FCC Caution

This device complies with Part 15 of the FCC Rules. Operation is subject to the following two conditions: (1) This device may not cause harmful interference, and (2) this device must accept any interference received, including interference that may cause undesired operation.

Canadian ICES Statement

Canadian Department of Communications Radio Interference Regulations

This digital apparatus does not exceed the Class B limits for radio-noise emissions from a digital apparatus as set out in the Radio Interference Regulations of the Canadian Department of Communications. This Class B digital apparatus complies with Canadian ICES-003.

Règlement sur le brouillage radioélectrique du ministère des Communications

Cet appareil numérique respecte les limites de bruits radioélectriques visant les appareils numériques de classe B prescrites dans le Règlement sur le brouillage radioélectrique du ministère des Communications du Canada. Cet appareil numérique de la Classe B est conforme à la norme NMB-003 du Canada.

European Union and European Free Trade Association (EFTA) Regulatory Compliance

This equipment may be operated in the countries that comprise the member countries of the European Union and the European Free Trade Association. These countries, listed in the following paragraph, are referred to as The European Community throughout this document:

AUSTRIA, BELGIUM, BULGARIA, CYPRUS, CZECH REPUBLIC, DENMARK, ESTONIA, FINLAND, FRANCE, GERMANY, GREECE, HUNGARY, IRELAND, ITALY, LATVIA, LITHUANIA, LUXEMBOURG, MALTA, NETHERLANDS, POLAND, PORTUGAL, ROMANIA, SLOVAKIA, SLOVENIA, SPAIN, SWEDEN, UNITED KINGDOM, ICELAND, LICHTENSTEIN, NORWAY, SWITZERLAND

Declaration of Conformity

Marking by this symbol indicates compliance with the Essential Requirements of the EMC Directive of the European Union 2004/108/EC.



This equipment meets the following conformance standards:

Safety:

CB- IEC 60065:2001 + A1:2005

NRTL - UL 60065:2003 R11.06, CSA C22.2 NO. 60065:2003 + A1:06

GS - EN 60065:2002 + A1

Additional licenses issued for specific countries available on request.

Emissions:

EN 55103-1: 1996

EN61000-3-2:2006, EN61000-3-3:1995 +A1:2001 +A2:2005

Immunity:

EN 55103-2: 1996

EN61000-4-2:1995 + A1:1999 + A2:2001, EN61000-4-3:2006, EN61000-4-4:2004,

EN 61000-4-5: 2005, EN 61000-4-6:2007, EN61000-4-11:2004

The product is also licensed for additional country specific standards as required for the International Marketplace.



Warning!

This is a Class B product. In a domestic environment, this product may cause radio interference, in which case, the user may be required to take appropriate measures.

Achtung! Dieses ist ein Gerät der Funkstörgrenzwertklasse B. In Wohnbereichen können bei Betrieb dieses Gerätes Rundfunkstörungen auftreten, in welchen Fällen der Benutzer für entsprechende Gegenmaßnahmen verantwortlich ist.

Attention! Ceci est un produit de Classe B. Dans un environnement domestique, ce produit risque de créer des interférences radioélectriques, il appartiendra alors à l'utilisateur de prendre les mesures spécifiques appropriées.

Korea KCC Compliance Statement

A급 기기 (업무용 방송통신기자재)	이 기기는 업무용(A급) 전자파적합기기로서 판매자 또는 사용자는 이 점을 주의하시기 바라며, 가정외의 지역에서 사용하는 것을 목적으로 합니다.
Class A (Broadcasting Communication Equipment for Office Use)	As an electromagnetic wave equipment for office use (Class A), this equipment is intended to use in other than home area. Sellers or users need to take note of this.

Taiwan Compliance Statement

警告使用者：
這是甲類的資訊產品，在居住的環境中使用時，可能會造成射頻干擾，在這種情況下，使用者會被要求採取某些適當的對策。

This is a Class A product based on the standard of the Bureau of Standards, Metrology and Inspection (BSMI) CNS 13438, Class A.

Chinese Compliance Statement

This product has been tested to the following Chinese standards:

GB13837-2003, GB8898-2001, and GB17625.1-2003

This product meets the requirements of implementation rules for compulsory certification

(REF NO. CNCA-01C-17:2010) under certificate number 2012010805543191.

Translated Warning and Caution Messages

The following caution statements, warning conventions, and warning messages apply to this product and manual.



Warning Symbol





Hazard Warning



Caution Symbol

Before Operation Please Read These Instructions

	<p>Warning! Read and follow all warning notices and instructions marked on the product or included in the documentation.</p> <p>Avertissement ! Lisez et conformez-vous à tous les avis et instructions d'avertissement indiqués sur le produit ou dans la documentation.</p> <p>Warnung! Lesen und befolgen Sie die Warnhinweise und Anweisungen, die auf dem Produkt angebracht oder in der Dokumentation enthalten sind.</p> <p>¡Advertencia! Lea y siga todas las instrucciones y advertencias marcadas en el producto o incluidas en la documentación.</p> <p>Aviso! Leia e siga todos os avisos e instruções assinalados no produto ou incluídos na documentação.</p> <p>Avviso! Leggere e seguire tutti gli avvisi e le istruzioni presenti sul prodotto o inclusi nella documentazione.</p>
	<p>Warning! Do not use this device near water and clean only with a dry cloth.</p> <p>Avertissement! N'utilisez pas cet appareil près de l'eau et nettoyez-le seulement avec un tissu sec..</p> <p>Warnung! Das Gerät nicht in der Nähe von Wasser verwenden und nur mit einem trockenen Tuch säubern.</p> <p>¡Advertencia! No utilice este dispositivo cerca del agua y límpielo solamente con un paño seco.</p> <p>Aviso! Não utilize este dispositivo perto da água e limpe-o somente com um pano seco.</p> <p>Avviso! Non utilizzare questo dispositivo vicino all'acqua e pulirlo soltanto con un panno asciutto.</p>
	<p>Warning! Do not block any ventilation openings. Install in accordance with the manufacturer's instructions.</p> <p>Avertissement ! Ne bloquez aucune ouverture de ventilation. Suivez les instructions du fabricant lors de l'installation.</p> <p>Warnung! Die Lüftungsöffnungen dürfen nicht blockiert werden. Nur gemäß den Anweisungen des Herstellers installieren.</p> <p>¡Advertencia! No bloquee ninguna de las aberturas de la ventilación. Instale de acuerdo con las instrucciones del fabricante.</p> <p>Aviso! Não obstrua nenhuma das aberturas de ventilação. Instale de acordo com as instruções do fabricante.</p> <p>Avviso! Non ostruire le aperture di ventilazione. Installare in conformità con le istruzioni del fornitore.</p>

**Warning!**

Do not install near any heat sources such as radiators, heat registers, stoves, or other apparatus (including amplifiers) that produce heat.

Avertissement ! N'installez pas l'appareil près d'une source de chaleur telle que des radiateurs, des bouches d'air de chauffage, des fourneaux ou d'autres appareils (amplificateurs compris) qui produisent de la chaleur.

Warnung! Nicht in der Nähe von Wärmequellen wie Heizkörpern, Heizregistern, Öfen oder anderen Wärme erzeugenden Geräten (einschließlich Verstärkern) aufstellen.

¡Advertencia! No instale cerca de fuentes de calor tales como radiadores, registros de calor, estufas u otros aparatos (incluidos amplificadores) que generan calor.

Aviso! Não instale perto de nenhuma fonte de calor tal como radiadores, saídas de calor, fogões ou outros aparelhos (incluindo amplificadores) que produzam calor.

Avviso! Non installare vicino a fonti di calore come termosifoni, diffusori di aria calda, stufe o altri apparecchi (amplificatori compresi) che emettono calore.

**Warning!**

Refer all servicing to qualified service personnel. Servicing is required when the device has been damaged in any way, such as power-supply cord or plug is damaged, liquid has been spilled or objects have fallen into the device, the device has been exposed to rain or moisture, does not operate normally, or has been dropped.



Avertissement ! Référez-vous au personnel de service qualifié pour tout entretien. L'entretien est exigé quand l'appareil a été endommagé de quelque manière que ce soit, par exemple lorsque le cordon d'alimentation ou la prise sont endommagés, que du liquide a été versé ou des objets sont tombés dans l'appareil, que l'appareil a été exposé à la pluie ou à l'humidité, ne fonctionne pas normalement ou est tombé.

Warnung! Das Gerät sollte nur von qualifizierten Fachkräften gewartet werden. Eine Wartung ist fällig, wenn das Gerät in irgendeiner Weise beschädigt wurde, wie bei beschädigtem Netzkabel oder Netzstecker, falls Flüssigkeiten oder Objekte in das Gerät gelangen, das Gerät Regen oder Feuchtigkeit ausgesetzt wurde, nicht ordnungsgemäß funktioniert oder fallen gelassen wurde.

¡Advertencia! Consulte al personal calificado por cuestiones de reparación. El servicio de reparación se requiere cuando el dispositivo ha recibido cualquier tipo de daño, por ejemplo cable o espigas dañadas, se ha derramado líquido o se han caído objetos dentro del dispositivo, el dispositivo ha sido expuesto a la lluvia o humedad, o no funciona de modo normal, o se ha caído.

Aviso! Remeta todos os serviços de manutenção para o pessoal de assistência qualificado. A prestação de serviços de manutenção é exigida quando o dispositivo foi danificado mediante qualquer forma, como um cabo de alimentação ou ficha que se encontra danificado/a, quando foi derramado líquido ou caíram objectos sobre o dispositivo, quando o dispositivo foi exposto à chuva ou à humidade, quando não funciona normalmente ou quando foi deixado cair.

Avviso! Fare riferimento al personale qualificato per tutti gli interventi di assistenza. L'assistenza è necessaria quando il dispositivo è stato danneggiato in qualche modo, ad esempio se il cavo di alimentazione o la spina sono danneggiati, è stato rovesciato del liquido è stato rovesciato o qualche oggetto è caduto nel dispositivo, il dispositivo è stato esposto a pioggia o umidità, non funziona correttamente o è caduto.

	<p>Warning! Disconnect the external AC power supply line cord(s) from the mains power before moving the unit.</p> <p>Avertissement! Retirez le ou les cordons d'alimentation en CA de la source d'alimentation principale lorsque vous déplacez l'appareil.</p> <p>Warnung! Trennen Sie die Wechselstrom-Versorgungskabel vom Netzstrom, bevor Sie das Gerät verschieben.</p> <p>¡Advertencia! Cuando mueva la unidad desenchufe de la red eléctrica el/los cable(s) de la fuente de alimentación CA tipo brick.</p> <p>Advertência! Remova os cabos CA de alimentação brick da rede elétrica ao mover a unidade.</p> <p>Avvertenza! Scollegare il cavo dell'alimentatore quando si sposta l'unità.</p>
	<p>Hazard Warning! High Voltage. This situation or condition can cause injury due to electric shock.</p> <p>Avertissement! Tension élevée. Cette situation ou condition peut causer des blessures dues à un choc électrique.</p> <p>Warnung! Hochspannung. Diese Situation oder Bedingung kann zu Verletzungen durch Stromschlag führen.</p> <p>¡Advertencia! Alto voltaje . Esta situación o condición puede causar lesiones debidas a una descarga eléctrica.</p> <p>Aviso! Alta Tensão . Esta situação ou condição pode causar danos devido a choques elétricos.</p> <p>Avviso! Alta tensione. Questa situazione o condizione può causare lesioni a causa di scosse elettriche.</p>
	<p>Warning! Only use attachments and accessories specified and/or sold by the manufacturer.</p> <p>Avertissement! Utilisez seulement les attaches et accessoires spécifiés et/ou vendus par le fabricant.</p> <p>Warnung! Verwenden Sie nur Zusatzgeräte und Zubehör angegeben und / oder verkauft wurde durch den Hersteller.</p> <p>¡Advertencia! Utilice solamente los accesorios y conexiones especificados y/o vendidos por el fabricante.</p> <p>Aviso! Utilize apenas equipamentos/acessórios especificados e/ou vendidos pelo fabricante.</p> <p>Avviso! Utilizzare soltanto i collegamenti e gli accessori specificati e/o venduti dal produttore.</p>

**Warning!**

Do not defeat the safety purpose of the polarized or grounding-type plug. A polarized plug has two blades with one wider than the other. A grounding type plug has two blades and a third grounding prong. The wide blade or the third prong are provided for your safety. If the provided plug does not fit into your outlet, consult an electrician for replacement of the obsolete outlet.

Avertissement! La sécurité de la prise polarisée ou de la prise de type mise à la terre ne doit en aucun cas être empêchée de fonctionner. Une prise polarisée a deux broches, l'une étant plus large que l'autre. Une prise de type mise à la terre a deux broches et une troisième broche pour la mise à la terre. La broche large ou la troisième broche sont fournies pour votre sécurité. Si la prise fournie ne s'insère pas dans votre prise femelle, consultez un électricien pour le remplacement de la prise femelle obsolète.

Warnung! Der Sicherheitszweck des gepolten bzw. Schukosteckers ist zu berücksichtigen. Ein gepolter Stecker verfügt über zwei Pole, von denen einer breiter als der andere ist. Ein Schukostecker verfügt neben den zwei Polen noch über einen dritten Pol zur Erdung. Der breite Pol bzw. der Erdungspol dienen der Sicherheit. Wenn der zur Verfügung gestellte Stecker nicht in Ihren Anschluss passt, konsultieren Sie einen Elektriker, um den veralteten Anschluss zu ersetzen.

¡Advertencia! No eche por tierra la finalidad del tipo de enchufe polarizado con conexión a tierra. Un enchufe polarizado tiene dos espigas, una más ancha que la otra. Un enchufe con conexión a tierra tiene dos espigas iguales y una tercera espiga que sirve para la conexión a tierra. La espiga ancha, o la tercera espiga, sirven para su seguridad. Si el enchufe suministrado no encaja en el tomacorriente, consulte con un electricista para reemplazar el tomacorriente obsoleto.

Aviso! Não anule a finalidade da segurança da ficha polarizada ou do tipo ligação terra. Uma ficha polarizada tem duas lâminas sendo uma mais larga do que a outra. Uma ficha do tipo de ligação à terra tem duas lâminas e um terceiro terminal de ligação à terra. A lâmina larga ou o terceiro terminal são fornecidos para sua segurança. Se a ficha fornecida não couber na sua tomada, consulte um electricista para a substituição da tomada obsoleta.

Avviso! Non compromettere la sicurezza della spina polarizzata o con messa a terra. Una spina polarizzata ha due spinotti, di cui uno più largo. Una spina con messa a terra ha due spinotti e un terzo polo per la messa a terra. Lo spinotto largo o il terzo polo sono forniti per motivi di sicurezza. Se la spina fornita non si inserisce nella presa di corrente, contattare un elettricista per la sostituzione della presa obsoleta.

**Warning!**

Since the Mains plug is used as the disconnection for the device, it must remain readily accessible and operable.

Avertissement! Puisque la prise principale est utilisée pour débrancher l'appareil, elle doit rester aisément accessible et fonctionnelle.

Warnung! Da der Netzstecker als Trennvorrichtung dient, muss er stets zugänglich und funktionsfähig sein.

¡Advertencia! Puesto que el enchufe de la red eléctrica se utiliza como dispositivo de desconexión, debe seguir siendo fácilmente accesible y operable.

Aviso! Dado que a ficha principal é utilizada como a desconexão para o dispositivo, esta deve manter-se prontamente acessível e funcional.

Avviso! Poiché il cavo di alimentazione viene usato come dispositivo di sconnessione, deve rimanere prontamente accessibile e operabile.

**Warning!**

Protect the power cord from being walked on or pinched particularly at plugs, convenience receptacles, and the point where they exit from the device.

Avertissement! Protégez le cordon d'alimentation pour que l'on ne marche pas dessus ou qu'on le pince, en particulier au niveau des prises mâles, des réceptacles de convenance, et à l'endroit où il sort de l'appareil.

Warnung! Vermeiden Sie, dass auf das Netzkabel getreten oder das Kabel geknickt wird, insbesondere an den Steckern, den Steckdosen und am Kabelausgang am Gerät.

¡Advertencia! Proteja el cable de energía para que no se le pise ni apriete, en especial cerca del enchufe, los receptáculos de conveniencia y el punto del que salen del equipo.

Aviso! Proteja o cabo de alimentação de ser pisado ou de ser comprimido particularmente nas fichas, em tomadas de parede de conveniência e no ponto de onde sai do dispositivo.

Avviso! Proteggere il cavo di alimentazione in modo che nessuno ci cammini sopra e che non venga schiacciato soprattutto in corrispondenza delle spine e del punto in cui esce dal dispositivo.

**Warning!**

Unplug this device during lightning storms or when unused for long periods of time.

Avertissement! Débranchez cet appareil pendant les orages avec éclairs ou s'il est inutilisé pendant de longues périodes.

Warnung! Das Gerät ist bei Gewitterstürmen oder wenn es über lange Zeiträume ungenutzt bleibt vom Netz zu trennen.

¡Advertencia! Desenchufe este dispositivo durante tormentas eléctricas o cuando no se lo utilice por largos periodos del tiempo.

Aviso! Desconecte este dispositivo da tomada durante trovoadas ou quando não é utilizado durante longos períodos de tempo.

Avviso! Utilizzare soltanto i collegamenti e gli accessori specificati e/o venduti dal produttore, quali il treppiedi e l'esoscheletro.

**Warning!**

Do not open the chassis. There are no user-serviceable parts inside. Opening the chassis will void the warranty unless performed by an AJA service center or licensed facility.

Avertissement! Ne pas ouvrir le châssis. Aucun élément à l'intérieur du châssis ne peut être réparé par l'utilisateur. La garantie sera annulée si le châssis est ouvert par toute autre personne qu'un technicien d'un centre de service ou d'un établissement agréé AJA.

Warnung! Öffnen Sie das Gehäuse nicht. Keine der Geräteteile können vom Benutzer gewartet werden. Durch das Öffnen des Gehäuses wird die Garantie hinfällig, es sei denn, solche Wartungsarbeiten werden in einem AJA-Service-Center oder einem lizenzierten Betrieb vorgenommen.

¡Advertencia! No abra el chasis. El interior no contiene piezas reparables por el usuario. El abrir el chasis anulará la garantía a menos que se lo haga en un centro de servicio AJA o en un local autorizado.

Advertência! Não abra o chassi. Não há internamente nenhuma peça que permita manutenção pelo usuário. Abrir o chassi anula a garantia, a menos que a abertura seja realizada por uma central de serviços da AJA ou por um local autorizado.

Avvertenza! Non aprire lo chassis. All'interno non ci sono parti riparabili dall'utente. L'apertura dello chassis invaliderà la garanzia se non viene effettuata da un centro ufficiale o autorizzato AJA.

**Warning!**

To meet safety regulations for leakage current, connect the dual power supplies to separate branch circuits.

¡Advertencia! Para cumplir con las normas de seguridad para la corriente de fuga, conecte las dos fuentes de alimentación para circuitos derivados diferentes.

Attention! Pour répondre aux mesures de sécurité concernant le courant de fuite, raccorder les sources d'alimentation doubles à des circuits de dérivation distincts.

Warnung! Zur Erfüllung der Sicherheitsbestimmungen bezüglich Reststrom schließen Sie bitte die zwei Netzteile an unterschiedlichen Abzweigungen an.

Cuidado! Para atender aos regulamentos de segurança para correntes de fuga, conecte as fontes duplas a circuitos elétricos separados.

Attenzione! Per soddisfare le norme di sicurezza sulla corrente di perdita, collegare i doppi alimentatori a circuiti derivati separati.

Index

Numerics

- 10/100/1000 Base-TX Ethernet Connector 28
- 3G Video
 - Fiber1 3G Detect Menu 56
 - Fiber2 Input Protect Menu 56
 - SDI1 3G Detect Menu 54

A

- AC Power
 - Connection 15
 - Specifications 107
 - Voltage 28
 - Warnings 28
- Address, IP 43
- Adjust and Select Knobs 18, 40
- AES/EBU Audio
 - AES/EBU Audio Out Menu 61
 - AES/EBU SRC Bypass 57
- AFD
 - AFD Out SDI2 Menu 74
 - AFD VANC Output Lines Menu 75
- AJA Technical Support 86
- ALARM LED 20
- Alarms
 - Configuration Screen 90
 - Power Supply 51
 - Reference 51
 - Vid1 Format 51
 - Vid2 Format 51
 - Video Format 104
 - Video Incompatibility 21
- Alphanumeric Display 16
- Analog Audio
 - Analog Audio Out Menu 62
 - Analog Audio Std Menu 54
 - Connections (pinout) 109
- Applications, Typical 11
- Audio
 - Audio 1 Button 18
 - Audio 1 Menu Group 18
 - Audio Delay (mS) Menu 81, 82
 - Audio Follow Video Menu 80
 - Audio Input Menu 78
 - Audio Level Ch1–16 Menu 83
 - Audio Map Ch 1/2 through Ch15/16 Menu 80
 - Audio Map Ch1–16 Menu 79
 - Audio Output Levels Menu 82
 - Audio Output Phase Menu 83

- Audio Phase Ch1–16 Menu 83
- Audio Proc 1 and Audio Proc 2 Menu Groups 98
- Audio Processor Block Diagram 13
- Audio SG Menu 81
- Dolby Framer Input Menu 84
- Dolby Framer Offset (Frames) Menu 84
- Dolby Framer Offset (Samples) Menu 84
- Dolby Framer Sync Menu 83
- Embedded Audio Out Menu 80
- Features 11
- Input/Output Connections 35
- Inputs and Outputs, Specifications 106
- Level Choices 35
- Levels, Specifications 106
- Audio 1 & 2 browser screens 98
- Authentication 47

B

- Background Fill Menu 64
- Block Diagram, FS2 System 13
- Box
 - Contents, Shipping 26
- Browser
 - Connecting to FS2 85
 - Supported 85
- Browser Control 33, 85
 - via Ethernet 12
- Browser Screens
 - Audio 1 & 2 98
 - Config 93
 - Network 88, 92
 - Output 96
 - Presets 95
 - Status 85, 90
 - Update Firmware 100
 - Video 1 & 2 97
- Buttons 15, 16
 - Audio 1 18
 - Config 17, 49
 - Menu Group 16
 - Output 17
 - Preset 17, 52
 - Remote 17, 46
 - Status 17, 44
 - System 17
 - Video 1 17
 - Video Proc 1 and Video Proc 2 62

C

- Cable Connections 35
- Caption Status 45
- Chassis, Mounting 28
- Closed Captioning Translator Menu 75
- Color Corrector (RGB) 70
- Color Red Gain 70
- Compliance Statements 110
- Component Video
 - Component In Format Menu 53
 - Component Out Format Menu 54
 - Component Out Menu 61
 - Component Video Input Specifications 105
- Composite Video
 - Composite Analog Video Input Specifications 106
 - Composite Downconv Crop Menu 57
 - Composite Out Menu 61
- Computer Formats 36
 - Browser Video Format Display 87
 - Connection 36
 - Genlock Source Menu 56
 - Genlocking 37
 - Menu Setup 37
 - Scaling 37
 - Specifications, Format List 106
 - Status Menu 44
- Config browser screen 93
 - Display Intensity 94
- Config Button 17
- Config Menu Group 17, 49
- Connection Status 86
- Connection, Computer Video 36
- Connectors 21
 - GPI Inputs/Outputs 22
 - GPI pinouts 108
 - Summary Descriptions 21
- Contents, Shipping Box 26
- Control
 - Browser 12, 33, 85
 - Features 11
 - Multiple FS2s 86
 - Overview 12
 - SNMP 12
- Control Buttons, Knobs, and Display 15
- Controls and Indicators Descriptions 15
- Conversion Exceptions 104
- Conversions, Disallowed List 20
- Cooling Requirements 28
- Custom
 - Custom Aspect Menu 71
 - Custom Bottom Crop Menu 71

- Custom H Position Menu 71
- Custom Left Crop Menu 71
- Custom Right Crop Menu 71
- Custom Size Menu 71
- Custom Size/Pos Menu 71
- Custom V Position Menu 71

D

- Default Gateway
 - Menu 50
- Depth 28
- Description, Technical 13
- Dimensions, Chassis 28
- Display 16
 - Description 15
 - Display Intensity 94
 - Display Intensity Menu 52
 - Menus 39
- Dolby
 - Dolby Decoder Aux Mode Menu 60
 - Dolby Decoder Aux Out Menu 59
 - Dolby Decoder Input Menu 59
 - Dolby Decoder Mode Menu 59
- Dolby Decoder Installation 28
- Downconversion
 - Downconvert AFD Default Menu 75
 - Downconvert Mode Menu 65
- DVI Formats (see Computer Formats) 36

E

- Equipment, Mounting 28
- Ethernet Connections
 - Supported 85
- Ethernet Connector 28
- Ethernet Specifications 106
- Export 96
- Export All 96
- EXT LED 20

F

- Factory Preset Menu 53
- Factory Settings, Resetting To 86
- Fan Speed Setting 52
- Features
 - Audio 11
 - Control 11
 - Video 10
- Fiber
 - Fiber I/O Installation 27
 - Fiber1 1080p50/60 Config Menu 62
 - Fiber1 Video Out Menu 61
 - Fiber2 1080p Config Menu 62
 - Fiber2 Video Out Menu 61
- Formats

- Component Video Inputs *105*
- FMT ERR 1/2 LEDs *19*
- HDMI Input *105*
- Incompatible Video List *20*
- Video *104*
- Video Inputs *104*
- Frame Rate Menu *56*
- Frame, Mounting *28*
- Freeze Output Menu *77*
- Front Panel *15*
- Front Panel Description *15*
- G**
- Gateway Address
 - Default *29*
- Genlock
 - Genlock Source Menu *56*
- Genlocking Computer Formats *37*
- GPIs
 - GPI 1–4 OUT Menu *48*
 - GPI Connections *35*
 - GPI Connections (pinout) *108*
 - GPI I/O Specifications *107*
 - GPI IN 1–4 Response Menu *47*
 - GPI Inputs/Outputs Connectors *22*
 - GPI Typical Connections *108*
- H**
- HDMI
 - HDMI Audio Out Menu *61*
 - HDMI RGB Range *57*
 - HDMI Video Input Specifications *105*
 - HDMI Video Out Menu *61*
- Height *28*
- Hidden Menus *52, 94*
- Host, UPnP *94*
- I**
- I/O Status *44*
- ID LED *20*
- Import *96*
- Import All *96*
- Incompatible Video Formats *20*
- Inputs and Outputs, Selection and Format *22*
- Installation
 - Dolby Decoder *28*
 - Fiber I/O Options *27*
 - Option Cards *27*
 - Overview *24*
 - Summary *25*
 - Unpacking *26*
- IP
 - IP Address *85*
 - IP Address Menu *50*
 - IP Address, Static Default *30*
 - IP Config Menu *49*
- IP Address *43, 89*
- Default *29*
- IP Config *88*
- K**
- Knobs *15*
- L**
- LAN *28*
- LAN Connection Diagram *28*
- LAN LED *20*
- LAN Specifications *106*
- LED Indicators *19*
- Legalizer White Clip Menu *73*
- Loss of Input Menu *64*
- M**
- MAC Address Menu *50*
- Manual, Contents Summary *14*
- Matte Chroma Menu *69*
- Matte Hue Menu *69*
- Matte Luma Menu *69*
- Menu Group Buttons *16, 40*
- Menu Groups
 - Audio *1 18*
 - Audio Proc 1 and Audio Proc 2 *98*
 - Config *17, 49*
 - Output *17, 60*
 - Preset *17, 52*
 - Remote *17, 46*
 - Status *17, 44*
 - System *17*
 - Video *1 17*
 - Video Proc 1 and Video Proc 2 Menu Groups *62*
- Menu Operation Examples *41*
- Menus
 - AES/EBU Audio Out *61*
 - AES/EBU SRC Bypass *57*
 - AFD Out SDI2 *74*
 - AFD VANC Output Lines *75*
 - Analog Audio Out *62*
 - Analog Audio Std *54*
 - Audio Delay (mS) *81, 82*
 - Audio Follow Video *80*
 - Audio Input *78*
 - Audio Level Ch1–16 *83*
 - Audio Map Ch 1/2 through Ch15/16 *80*
 - Audio Map Ch1–16 *79*
 - Audio Output Levels *82*
 - Audio Output Phase *83*
 - Audio Phase Ch1–16 *83*

Audio SG 87
 Background Fill 64
 Caption Status 45
 Closed Captioning Translator 75
 Color Corrector (RGB) 70
 Color Green Gain 70
 Color Red Black Level 70
 Color Red Gamma 70
 Component In Format 53
 Component Out 61
 Component Out Format 54
 Composite Downconv Crop 57
 Composite Out 61
 Custom Aspect 71
 Custom Bottom Crop 71
 Custom H Position 71
 Custom Left Crop 71
 Custom Right Crop 71
 Custom Size 71
 Custom Size/Pos 71
 Custom V Position 71
 Default Gateway 50, 89
 Display Intensity 52
 Dolby Decoder Aux Mode 60
 Dolby Decoder Aux Out 59
 Dolby Decoder Input 59
 Dolby Decoder Mode 59
 Dolby Framer Input 84
 Dolby Framer Offset (Frames) 84
 Dolby Framer Offset (Samples) 84
 Dolby Framer Sync 83
 Downconvert AFD Default 75
 Downconvert Mode 65
 Embedded Audio Out 80
 Factory Preset 53
 Fiber1 1080p50/60 Config 62
 Fiber1 Video Out 61
 Fiber1-3G Detect 56
 Fiber2 1080p Config 62
 Fiber2 Input Protect 56
 Fiber2 Video Out 61
 Frame Rate 56
 Freeze Output 77
 Genlock Source 56
 GPI IN 1–4 Response 47
 GPI OUT 1–4 48
 HDMI Audio Out 61
 HDMI RGB Range 57
 HDMI Video Out 61
 Hidden 52, 94
 I/O Status 44
 IP Address 50
 IP Config 49
 Legalizer White Clip 73
 Loss of Input 64
 MAC Address 50
 Matte Chroma 69
 Matte Hue 69
 Matte Luma 69
 NTSC Standard 57
 Output Format 63
 Output Status 45
 Output Timing H 73
 Output Timing V 73
 Power Supply Alarm 51
 Power/Temp Alarm Status 45
 Presets 1–40 53
 Proc Amp (YUV) 69
 Proc Amp Black 69
 Proc Amp Gain 69
 Proc Amp Hue 69
 Proc Amp Sat 70
 Reboot 52
 Reference Alarm 51
 Remote Control 46
 Scan Format 76
 Screen Saver 52
 SD Aspect Ratio Convert 67
 SDI1 1080p Config 62
 SDI1 Video Output 60
 SDI1-3G Detect 54
 SDI2 1080p Config 62
 SDI2 Video Out 60
 Serial Number 52
 Sidebar Edge 68
 SNMP Enable 103
 SNMP Trap Destination 1 103
 SNMP Trap Destination 2 103
 SNMP Trap Port 1 103
 SNMP Trap Port 2 103
 Software Version 52
 Subnet Mask 50
 System Name 46, 49
 Test Pattern Video 77
 Upconvert Line 21 76
 Upconvert Mode 64
 Vid 1 Format Alarm Status 44
 Vid 2 Format Alarm Status 45
 Vid 2 Format Status 45
 Vid1 Format Alarm 51
 Vid1 Format Status 44
 Vid2 Format Alarm 51
 Video Input 63
 Video Legalizer 73
 Video Output Mode 64
 Menus, Parameter 39

- Multilevel Menus
 - Vid1 ProcAmp 42
- Multiple Field Parameter Menus
 - IP Address 43
- Multiple FS2s, Controlling 86
- N**
- Network
 - Connection Diagram 28
 - Default Gateway 89
 - Default Gateway Address 29
 - Default IP Address 29
 - Default Subnet Mask 29
 - IP Address 89
 - IP Config 88
 - Ping Test 32
 - Screen 88
 - Subnet Mask 89
 - UPnP Host 94
 - UPnP Proxy 94
- Network screen 92
- NTSC 22, 57
 - NTSC Standard Menu 57
- NTSC Japan 57
- O**
- Operation Examples 41
- Operational Summary 16
- Option Card Installation 27
- Output
 - Output Button 17
 - Output Format Menu 63
 - Output Menu Group 17, 60
 - Output Status 45
 - Output Timing H Menu 73
 - Output Timing V Menu 73
 - Outputs and Inputs, Selection and Format 22
- Output browser screen 96
- Overview 10
- Overview, Installation 24
- Overview, System Block 13
- P**
- PAL 22
- PAL-M 57
- Panel
 - Description, Front 15
 - illustrations 15
 - Rear, Description 21
- Parameter Menus 39
- Physical Specifications 107
- Ping Test, Network 32
- Power
 - Connection 15
 - Power Supply Alarm Menu 51
 - PWR 1/2 LEDs 20
 - Requirements and Warnings 28
 - Specifications 107
- Power/Temp Alarm Status 45
- Preset Button 17
- Preset Menu Group 17, 52
- Presets
 - Presets 1–40 Menu 53
- Presets browser screen 95
- Proc Amp
 - PROC AMP 1/2 LEDs 19
 - Proc Amp Black Menu 69
 - Proc Amp Gain Menu 69
 - Proc Amp Hue Menu 69
 - Proc Amp Menu (YUV) 69
 - Proc Amp Sat Menu 70
- Processor 1 & Processor 2 13
- Proxy, UPnP 94
- Pst # 95
- Pushbuttons 16
- PWR 1/2 LEDs 20
- R**
- Rear Panel Description 21
- Reboot Menu 52
- Recall (91.1) 95
- Redundant Power Supplies 15
- Reference
 - Ref Connector 20
 - Ref LED 19
 - Reference Alarm Menu 51
 - Video Reference Specifications 106
- Region of Interest 72
- Remote Button 17
- Remote Control Menu 46
- Remote LED 19
- Remote Menu Group 17, 46
- Resetting to Factory Setting 86
- RGB
 - Color Green Gain Menu 70
 - Color Red Black Level Menu 70
 - Color Red Gamma Menu 70
 - RGB 22
 - RGB Color Corrector Menu 70
- RS-422 specifications 107
- S**
- Safety Statements 110
- Save (92.1) 95
- Scaling, Computer Video 37
- Scan Format Menu 76

- Screen Description (Browser), General 85
- Screen Saver Menu 52
- SD Aspect Ratio Convert Menu 67
- SDI
 - SDI video 22
 - SDI1 1080p Config Menu 62
 - SDI1 Video Output Menu 60
 - SDI2 1080p Config Menu 62
 - SDI2 Video Out Menu 60
- Select and Adjust Knobs 18, 40
- Serial Number 86
- Serial Number Menu 52
- Shipping Box Contents 26
- Sidebar Edge Menu 68
- Simple Menus (Config Format Alarm Filters) 41
- SNMP
 - SNMP Alarm Traps 101
 - SNMP Enable Menu 103
 - SNMP Interface 12
 - SNMP Trap Dest 1 & Dest 2 101
 - SNMP Trap Destination 1 Menu 103
 - SNMP Trap Destination 2 Menu 103
 - SNMP Trap Port 1 Menu 103
 - SNMP Trap Port 2 Menu 103
 - SNMP, FS2 Implementation 101
- Software Update Procedure 33
- Software Version 86
- Software Version Menu 52
- Specifications
 - Appendix A 104
 - Audio I/O 106
 - Audio levels 106
 - Component Analog I/O 105
 - Composite Analog I/O 106
 - Conversion Exceptions 104
 - HDMI I/O 105
 - Physical 107
 - Power 107
 - Reference video 106
 - Video Formats 104
 - Video Input/Output 104
- Status
 - Caption Status 45
 - Dolby Framer Status 46
 - I/O 44
 - Output Status 45
 - Power/Temp Alarm Status 45
 - Status Button 17, 44
 - Status Menu Group 17, 44
 - STATUS Menus 41
 - Status Screen 85
 - System Name 46
 - Vid 1 Format Alarm Status 44
 - Vid 2 Format Alarm Status 45
 - Vid 2 Format Status 45
 - Vid1 Format 44
- Status browser screen 90
- Subnet Mask 89
 - Default 29
- Subnet Mask Menu 50
- Summary, Installation 25
- Support, AJA Technical 86
- S-Video 22
- System
 - System Block Diagram 13
 - System Button 17
 - System Menu Group 17
 - System Name Menu 49
- System Name 46

T

- TASCAM-style Connector Pinout 109
- Technical Description 13
- Technical Support, AJA 86
- Test Pattern Video Menu 77
- Typical Applications 11

U

- UFC 1/2 LEDs 19
- Unpacking 26
- Upconvert Line 21 Menu 76
- Upconvert Mode Menu 64
- Update Firmware screen 100
- Update the Software 33
- UPnP Host 94
- UPnP Proxy 94

V

- VESA Formats (see Computer Formats) 36
- Vid1 Format Alarm Status 44
- Vid1 Format Status 44
- Vid2 Format Alarm Status 45
- Vid2 Format Status 45
- Video
 - A/D, D/A Specifications 106
 - Component Input Specifications 105
 - Composite Input Specifications 106
 - Features 10
 - HDMI Input Specifications 105
 - VID IN 1/2 LEDs 19
 - Vid1 Format Alarm Menu 51
 - Vid2 Format Alarm Menu 51
 - Video 1 Button 17
 - Video 1 Menu Group 17
 - Video and Audio I/O Connections 35
 - Video Format Specifications 104
 - Video Incompatibility Alarms 21

- Video Input Format Specifications *104*
- Video Input Menu *63*
- Video Legalizer Menu *73*
- Video Output Mode Menu *64*
- Video Proc 1 and Video Proc 2 Menu
Groups *62*
- Video Processor Block Diagram *13*
- Video 1 & 2 browser screens *97*
 - Color Red Gain *70*
- Video Format Alarms *104*
- Voltage, AC *28*

W

- Warnings
 - AC Leakage Current *15*
 - AC Power *28*
 - Installation *24*
 - Safety *110*
- Web Browser Control *33, 85*
- Width *28*