



User Manual

L7

Arnold & Richter Cine Technik GmbH & Co. Betriebs KG
D-83071 Stephanskirchen
Germany

Kontaktinformationen unter / For contact information visit
www.arri.com

Table of Contents

1.	General	4
1.1	Important Notes and Safety Instructions	4
1.1.1	General Notes	4
1.1.2	Important Safety Instructions	4
1.2	Description and Features of your Lamphead	5
1.2.1	Properties	5
1.2.2	Product features	5
2.	General Lamphead Overview	6
3.	Setting up and Securing the Fixture	7
4.	Basic Functions	8
5.	Setting Options	8
5.1	Possible Settings via On-board Control	9
5.1.1	Overview of on-board control	9
5.1.2	Menu levels of the on-board control	10
5.1.3	Setting the operating modes	11
5.1.4	Setting the color temperature (CCT mode)	11
5.1.5	Setting the color (HSI mode)	11
5.1.6	Setting intensity	11
5.1.7	Setting the fan function	11
5.1.8	Setting the DMX address	11
5.1.9	Signal lost behavior	12
5.1.10	Selecting the DMX profile	12
5.1.11	Turning lights on/off and status request of on-board control	12
5.1.12	Status request	12
	a) Operating hours	12
	b) DMX version	12
	c) Software version	12
	d) Operating temperature	12
	e) Availability	12
5.1.13	Error messages	13
5.1.14	Error messages	13-14

5.2	Possible Settings via DMX	14
5.2.1	DMX profiles	14
5.2.2	DMX In / Pin allocation	14
5.2.3	DMX Implementation table	15 - 22
5.2.4	Conversion CCT value to DMX %	22
5.2.5	RDM functions	23 - 25
5.3	LSeries Manager	25
6	Technical Data	26 - 27
7	EC Declaration of Conformity, Service	28

© 2012-2013 Arnold & Richter Cine Technik GmbH & Co. KG Betriebs KG (ARRI). All rights reserved. ARRI assumes no responsibility for the accuracy and completeness of the information. Information are subject to change without notice. ARRI and affiliated companies disclaim liability for any damage, direct or indirect loss, economic loss or any other loss occasioned by the use of, inability to use or reliance on the information contained in this document. The ARRI logo, the ARRI name and all other trademarks in this document pertaining to services or products by ARRI or its affiliates and subsidiaries are trademarks owned or licensed by ARRI or its affiliates or subsidiaries.

1. General

1.1 Important Notes and Safety Instructions

1.1.1 General Notes

- ARRI L Series fixtures are intended for professional use in the studio and on location and may only be operated by qualified persons.
- Read these instructions carefully before using the device for the first time. The following text contains important information for safe handling.
- Observe the safety instructions and warnings for your own personal safety.
- All components comply with the following European standards and directives:
 - Low voltage directive
 - EMC directive
 - RoHS directive
- Keep these instructions for possible subsequent owners.
- Help protecting our environment by disposing the packing material at your local recycling center.
- Use only original ARRI spare parts and accessories (more information at www.arri.com).

1.1.2. Important Safety Instructions

- **DANGER OF LIFE - MAINS VOLTAGE!**
Disconnect the device from the mains voltage before replacing a damaged fuse!
 Never bridge a fuse!
- **CAUTION ! Risk of burns !**
 The housing and the cooling fins can reach high temperatures.
 Keep a safety distance of 20" (0,5 m) to adjacent surfaces on all sides.
 Keep the cables away from the fixtures.
 Do not cover ventilations slots and cooling fins.
- **CAUTION ! High Beam Intensity !**
 Do not look into the light emission aperture of the fixture.
- Safety devices may only be removed for service purposes by qualified personnel !
- Do not lift or suspend the fixture at the mains cable !
- Note the technical data on page 29 and 30.
- Do not use the fixture or accessories if they display any visible damage on any component.
 In case of damage the respective parts must be exchanged or you have to contact an ARRI Service station (see www.arri.com).
- L7 fixtures must not be connected to dimmer systems or dimmer channels in Non-Dim mode.
 Doing so will damage the electronic system of the fixture.
- Check the fixture for the following possible damage before every use:



<i>part</i>	<i>possible damage</i>
housing, lens	fissures, cracks, deformed
cables	deformed, cut, scorched
plug	deformed, broken, scorched
plug connections	damaged
inner thread	overwound



Also read and follow the additional safety leaflet "Operating your ARRI Lampheads safely" L5.70731.E

1.2 Description and features of your Lamphed

The L7 range lampheds are equipped with an electronically controlled LED light source. You can use them like a conventional tungsten Fresnel fixture but with far higher energy efficiency. The newly developed optical system offers a continuous focus range of 15-50° half peak angle and real 'Fresnel' characteristics: an extremely uniform light field and clean shadow rendition. The various types of L-series produce white or colored light with adjustable color temperature and green / magenta saturation. For more information, see "Specifications" on page 26. The light spectrum has been specifically designed for excellent color rendition. All fixtures can be controlled over USB interface, DMX 512 / RDM protocol or on-board control panel (if equipped).

1.2.1 Properties

- **Focus**
Versatility is the key element in traditional Fresnels, especially the ability to spot and flood the beam as needed. Whether it's a flood field for a pullback shot or a tight spot for a bright highlight, the continuous focusability of the L7 performs just as expected.
- **Versatile beam characteristics**
The L7 provides the same ability as conventional Fresnel lenses to cut set elements and shape the light field with barndoors and flags.
- **Even light field**
Clear, defined shadows have traditionally been a trait only of single source tungsten and daylight fixtures. ARRI L7 Fresnels provide the same single shadow properties designers expect, delivering natural results.
- **Vibrant colors, full-spectrum lighting**
True-to-life color rendition is an outstanding feature of the L range, comparable to a full-spectrum tungsten source. The fully tuneable White light of the L7 C can be adjusted for different skin tones, camera sensors and mixed-light environments. Full gamut color mixing enables the rendition of all color shades, making color filters dispensable.
- **Cool light beam**
Like all LED light sources the L7 does not emit infrared or UV radiation and thus no forward heat, making talent feel comfortable in the light beam.

The ARRI L range combines all advantages of LED technology and the traditional Fresnel lens. It integrates seamlessly into established working practices, so that designers can stick with their creative techniques and studios will have no need to change their operating procedures.

1.2.2 Product features

- **Focus knob**
True Blue-style focus knobs provide precise adjustment and rapid flood-to-spot with only three turns. Knobs on both sides of the fixture ensure easy access from all positions.
- **Sliding stirrup**
The sliding stirrup design enables precise compensation for front-end accessories.
- **Yoke**
With an extremely slim profile, the extruded aluminum yoke provides high strength without added weight. An optional pole-operated yoke allows full operation of pan and tilt from the floor and is therefore a popular choice for many studios.
- **Tilt lock**
The high strength tilt lock provides extremely secure locking, eliminating movement and slippage and ensuring that the fixtures will stay where you put them.
- **DMX control**
All functions of the L7 are controllable through DMX. The L7 is also fully RDM compatible and is equipped with a feedback channel for reporting all set parameters including system status and hours on the light engine.
- **On-board control**
For location applications the L7 is equipped with an on-board control for manual adjustment of intensity, color temperature and plus/minus Green as well as hue and saturation (functions available depending on type).

2. Lamphead overview

- 1 Power switch (optional)
- 2 Power cable
- 3 Fuse holder
- 4 USB port (Mini USB)
- 5 DMX input
- 6 DMX through
- 7 Handle
- 8 Spigot
- 9 Stirrup
- 10 Tilt lock
- 11 Top latch
- 12 Safety catch
- 13 Focus knob or P.O. gear
- 14 Control and indicator panel (not at all versions)
- 15 Stirrup bracket
- 16 Lens holder
- 17 Tilt lock lever

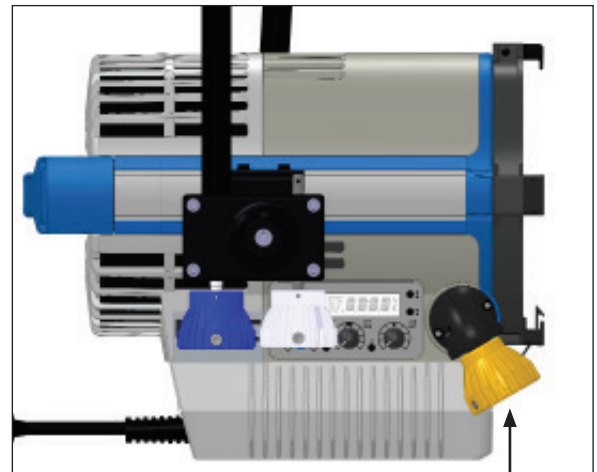
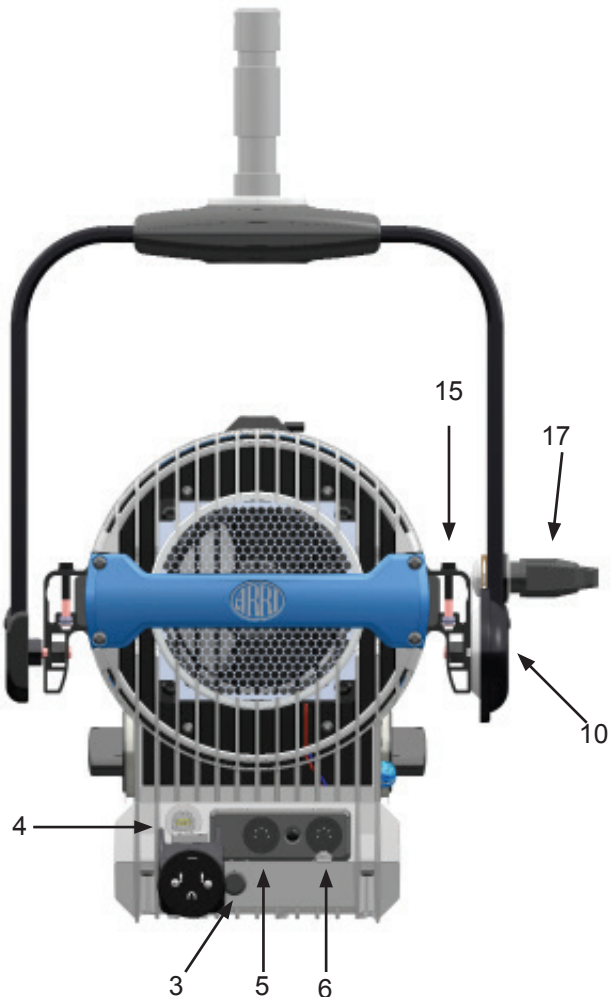
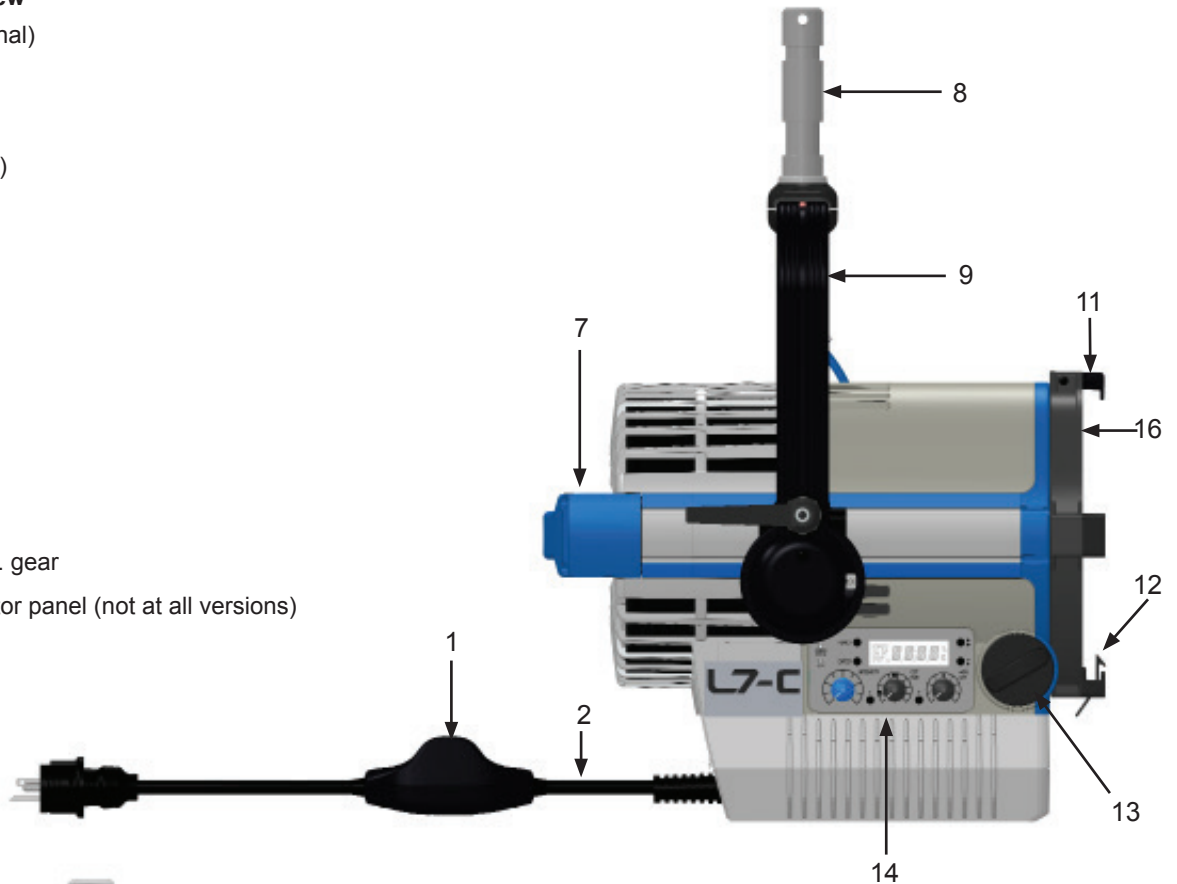

P.O. - Version

3. Setting up and securing the fixture

- Tools needed
Torx screwdriver no. 20
Torque wrench / Allen key no. 10 (50 Nm)
- Adjusting the stirrup
On delivery the stirrup (9) is in the basic position, which means it is tilted to the back.
Use the Torx screwdriver no. 20 to slightly loosen the screws on both sides of the stirrup bracket (15) and pull the stirrup bracket towards the rear of the lamphead. The lever of the tilt lock (10) has to be loosened, so that you can tilt the stirrup (9) upwards.
In order to position the stirrup at the ideal balance point move it to a position halfway in-between the front and rear of the lamphead housing. Then tighten the screws at the stirrup bracket (15) again. Now tilt the stirrup to the desired angle and tighten the tilt lock lever. For better leverage, press the knob on the tilt lock lever (17) and turn the lever to the desired position.
- Mounting the spigot
Place the spigot (8) and the spacer onto the boring in the stirrup (9), insert the screw with washer and spring washer from below and fasten it with the torque wrench to 50 Nm = 37 lbf ft (pound force feet).
- Installation of the PC software
Download the latest LSeries Manager version from the internet (download center: <http://www.arri.com/l-series/downloads>). Be aware that the installation can only be performed, if you have administrative rights. If your user profile does not grant administrative rights you have to let the installation file (.exe) run as follows:
Right-click on the file „start as administrator“.
Start the program by double-clicking on the generated shortcut.
After the installation is completed you can connect your lamphead via USB cable to your computer. The LSeries Manager automatically detects the connected lampheads. Make sure that no other DMX program is communicating with the lamphead. You can operate one lamphead with any one USB port.

Tip: After the installation is complete, we recommend connecting the lamphead before you start the LSeries Manager for the first time. Doing this will complete the driver installation and prevent a possible connection time-out.

Note: Wait with connecting your lamphead to the computer until the installation of the LSeries Manager is complete. The LSeries Manager allows you to operate several L7 lampheads and also update them simultaneously.

Securing the lamphead and the accessories

- When mounting the fixture in a hanging position, additionally secure the fixture with a safety cable from the mounting pipe or truss through the fixture stirrup. The safety cable must be properly dimensioned for the fixture and application and must be kept short.
- The carrying capacity of the safety rope must be rated at a minimum of 10 times the weight of the lamphead system including accessories.
- Be aware of the maximum allowed tilt angle of 90° up and 90° down.
- When the lamphead is operated in a hanging position, ensure that the accessories are installed correctly: top latch (11) locked, optional barndoor safety catch (12) snapped in.
- Stands must be set up in a stable position and capable of carrying the load of the lamphead including accessories and cables! Also refer to our safety leaflet "Operating Your ARRI Lampheads Safely"; L5.40731.E.

CAUTION! Lateral load can cause deformation or breaking of the spigot (8) or the stirrup (9)!

4. Basic functions

- **Securing the fixture**
The lamphead must be fastened at its stirrup (9) in a standing or hanging position. The spigot (8) must be inserted into the husk of a matching stand or a matching holding device and must be clamped in and secured there.
- **Rotation and tilt**
The lamphead can be rotated after the screw at the stand or holding device has been loosened. In order to change the tilt, loosen the tilt lock (10). After rotating or tilting the lamphead, the screws or lock levers must be tightened again.
- **Adjusting the beam angle**
The beam angle can be continuously adjusted by turning the focus knob (13). When you do this the entire lens unit is moved out of or into the lamphead housing.
This mechanism protects the fixture in two ways:
 - A predetermined breaking point prevents damage at the lamphead if the focus knob is turned with too much torque.
 - A self-impeding gear prevents that the position of the lens unit changes while the lamphead is operated in a tilted position.
- **Using accessories for light design**
Accessories for light design, such as a barndoor or filter holders, can be inserted into the holding brackets on the front of the lamphead. To do this proceed as follows:
 - Firmly press the button at the side of the top latch; the top latch flips upwards.
 - Insert the accessory from the upside into the holding brackets, until the safety catch (12) engages. Slightly tilt the safety catch with your finger for support.
 - Close the top latch (11) and make sure that the hook of the top latch engages in the holding ring of the accessory.
- **DMX interface**
The lamphead is equipped with an RDM/DMX interface with a waterproof input socket. The not waterproof DMX distributor box which is mounted at this socket has one DMX in and out and has the purpose of looping the DMX line through to the next lamphead. It can be removed after loosening the fixing screw.
- **USB interface**
The lamphead is also equipped with a USB interface with a mini USB slot, which can be used for updating the fixture's internal firmware, for adjusting operating parameters and for service purposes. The service tool "LSeries Manager" allows you to configure your lamphead via this interface, you can download the LSeries Manager from the ARRI homepage free of charge. (Download center: <http://www.arri.com/l-series/downloads>)
- **Turning on and operation**
After you have turned on the power switch (or after connecting to mains power for lampheads without a power switch) the lamphead will need a short start-up time before it lights up. The lamphead will operate with the previously used setting. It can now be controlled via the DMX interface or the on-board control.

CAUTION! High beam intensity ! Do not look into the light emission aperture of the lamphead.

5. Setting Options

You have four options to configure or control your lamphead:

Type	control	configuration
on-board control	yes	yes
USB - LS Manager	no	yes
DMX - mixing console or computer	yes	no
RDM - USB on RDM Box with PC software	yes	yes

5.1 Possible settings via on-board control

5.1.1 Overview of on-board control

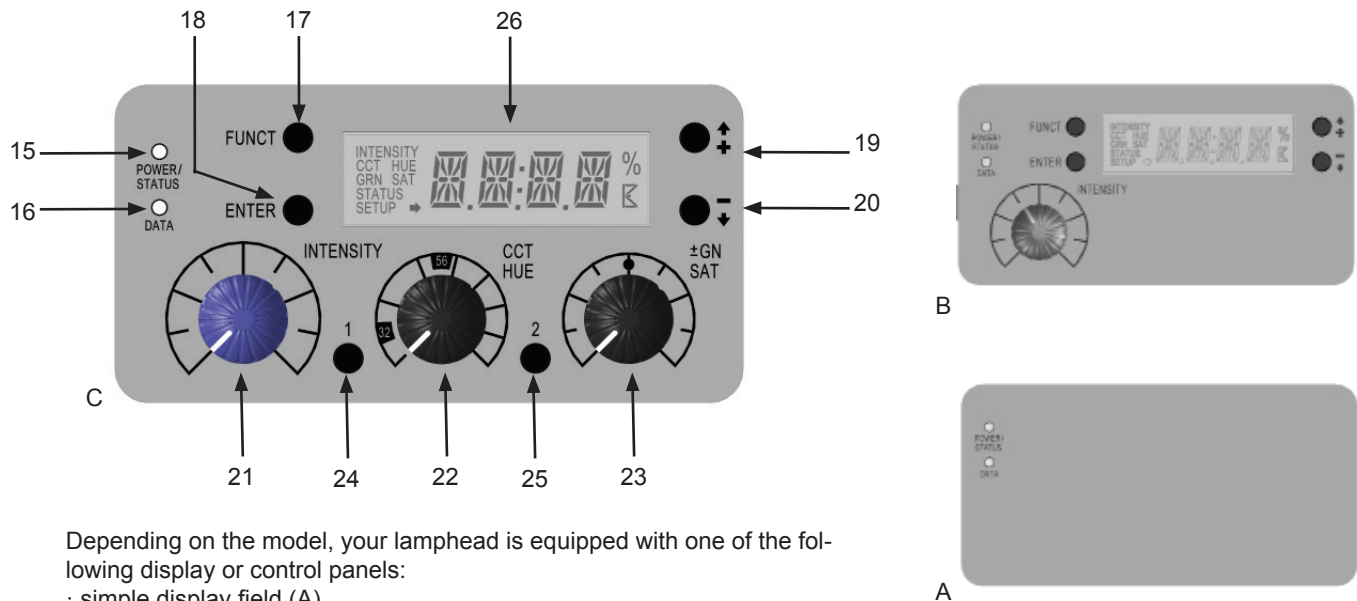

Depending on the model, your lamphed is equipped with one of the following display or control panels:

- simple display field (A)
- on-board control with LC display and intensity control (B)
- on-board control with LC display, intensity and color control (C)

no.	name	short description
15	POWER-/STATUS-LED display	lights up yellow when the lamphed is on.
16	DATA display	lights up blue when a valid DMX signal has been detected
17	FUNCT - button	1. function: changes between CCT & HSI mode 2. function: jump one menu level UP
18	ENTER - button	1. function: jump one menu level DOWN 2. function: confirm settings 3. function: „flash“ arrow for activating quick selection (calling memory 1 oder memory 2)
19	+ / UP / step up value	navigate within a menu level or step up values (keep button pressed for stepping up rapidly)
20	- / DOWN / step down value	navigate within a menu level or step down values (keep button pressed for stepping down)
21	rotary knob INTENSITY	set intensity
22	rotary knob CCT / HUE	set color temperature or hue
23	rotary knob GN / SAT	set green-magenta correction or saturation
24	memory button 1	safe or retrieve settings
25	memory button 2	safe or retrieve settings
26	display	

Status LEDs at on-board control:

green LED lights up	status OK / lamphed active
blue LED lights up	receiving DMX or RDM data
red LED flashes at 500ms rhythm *	lamphed will shortly reach over temperature
red LED lights up permanently *	over temperature reached
red LED goes out and Green LED lights up *	lamphed has cooled down and can be turned on again
red LED flashes rapidly at 250ms rhythm *	calibration data could not be loaded
* display lights up red when LED is lit	

5.1.2 Menu levels of the on-board control

During the operation of the lamphead the selected operating mode with the current value is displayed. On the first menu level the values for INTENSITY, CCT/HUE and GN/SAT can be retrieved via the + / - buttons. The menu point STATUS, confirmed with ENTER, takes you to the next level which displays information on faultless operation and the temperature. To retrieve values for operating hours, DMX version and software version, press ENTER to jump to the third level. The FUNCT key takes you back to the previous menu level.

Note: The horizontal arrow in the display symbolizes the possibility to jump to the next menu level by pressing ENTER.

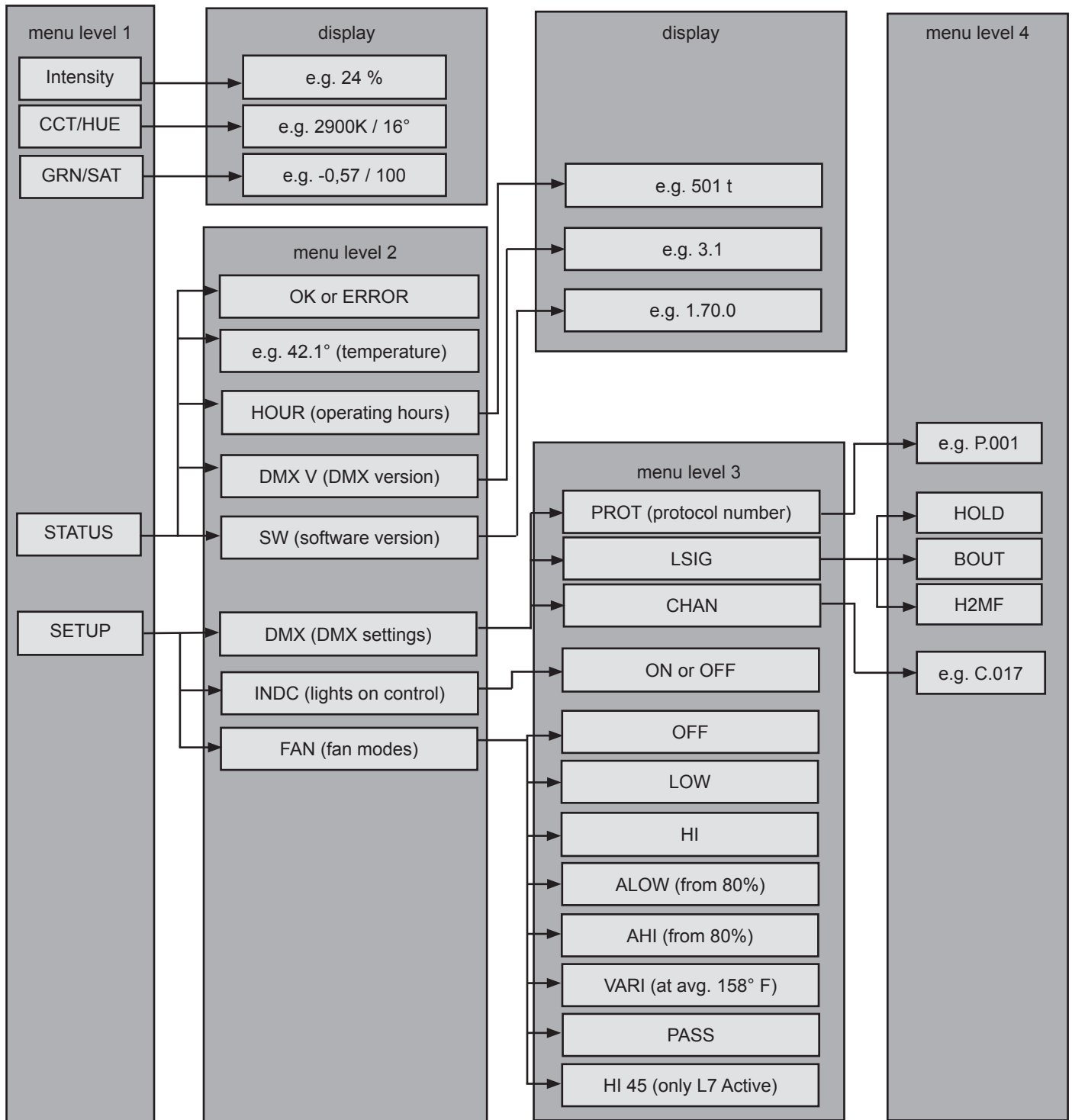

Note: In setup or status mode the settings option remains active until another function is executed. In all other modes the display will go back to the respective mode after 2 seconds.

5.1.3 Setting the operating modes

Press the FUNCT key (17) briefly to switch from CCT mode to HSI mode or vice versa.

In CCT mode the lamphead generates White light with optimized color rendition CRI > 95.

In HSI mode the lamphead generates colored light. If saturation is set very low, the lamphead will generate White light, but with optimized color rendition.

5.1.4 Setting the color temperature and Green-magenta adjustment in CCT mode

With the rotary knob CCT/HUE (22) the color temperature can be adjusted continuously.

The rotary knob GN/SAT (23) serves for continuous green-magenta adjustment.

You can retrieve the currently set value for Green-magenta adjustment by pressing the keys + (19) or - (20) repeatedly until GRN is displayed on the left side of the display (e.g. +0.23). The setting for color temperature is always displayed (e.g. 4150K).

5.1.5 Setting the color in HSI mode (only L7-C)

With the rotary knob CCT/HUE (22) you can adjust the value for hue continuously.

Use the rotary knob GN/SAT (23) for continuous adjustment of saturation.

You can retrieve the currently set value for saturation by pressing the keys + (19) or - (20) repeatedly until SAT is displayed on the left side of the display (e.g. 45). The setting for hue is always displayed (e.g. 4118°).

5.1.6 Setting intensity in both operating modes

With the rotary knob INTENSITY (21) you can continuously adjust intensity in both operating modes. You can retrieve the currently set value for intensity by pressing the keys + (19) or - (20) repeatedly until INTENSITY is displayed on the left side of the display (e.g. 24%).

5.1.7 Setting the fan functions

You can set the different fan functions via the on-board control from menu level 3.

Proceed as follows:

Press the keys + (19) or - (20) repeatedly until SETUP is displayed in the left lower corner of the display (27).

Confirm with the ENTER key (18). Press the key + (19) or - (20) repeatedly until FAN is shown in the display (27). Confirm with ENTER (18) again. The currently used fan mode is displayed.

By pressing the keys + (19) or - (20) you can select the desired fan mode (see table below). Confirm your selection with the ENTER key (18). The fan will now work in the desired mode. Press the FUNCT key (17) twice to leave this menu level.

Fan mode	L7 Hybrid	L7 Active	Description of mode
OFF	x		Fan is turned off, it may occur that the lamphead turns itself off due to overheating. Once the lamphead has cooled down it can be turned on and used again.
LOW	x	x	Fan operates constantly at low speed (silent)
HI	x		Fan operates constantly at maximum speed
A-LOW	x		Fan operates from 80% intensity with 1050 rev/min
A-HI	x		Fan operates from 80% intensity with maximum speed
VARI	x	x	Fan is controlled via the light-engine temperature, fan starts at approx. 70°C / 158° F, steps speed up or down automatically
PASS	x		No fan, light output is reduced by 20%
HI 45		x	Optimized for an ambient temperature of 45°C / 113° F, fan operates at max. speed, light output is reduced by approx 15%

5.1.8 Setting the DMX address

Go to menu level 4 to set the DMX start address via the on-board control.

Proceed as follows:

Press the keys + (19) or - (20) repeatedly until SETUP is displayed in the left lower corner of the display (27).

Confirm with the ENTER key (18). Press the key + (19) or - (20) repeatedly until DMX is shown in the display (27). Confirm with ENTER (18) again. Press the key + (19) or - (20) repeatedly until CHAN is shown in the display (27). When you press the ENTER key now the currently used DMX start address is displayed and flashes three times. Use the keys + (19) or - (20) to select a value from C.001 to C.506 and confirm your selection with the ENTER key (18). The DMX start address is now set. Press the FUNCT key (17) three times to leave this menu level.

5.1.9 Signal lost behavior

3 signal lost options are available:

- HOLD: DMX hold function, latest DMX values are reminded forever.
Re power the device clears the hold function or sending new DMX-Values.
- BOUT: BOUT means black out, after a DMX signal lost, the LedSpot dim immediately to zero.
- H2MF: Same as HOLD, but after 2 minutes the LedSpot dim to zero.

5.1.10 Selecting the DMX profile

In order to select one of the 15 available DMX profiles via the on-board control you have to navigate to menu level 4. To get there, proceed as follows:

Press the keys + (19) or - (20) repeatedly until SETUP is displayed in the left lower corner of the display (27).

Confirm with the ENTER key (18). Press the key + (19) or - (20) repeatedly until DMX is shown in the display (27). Confirm with ENTER (18) again. Press the key + (19) or - (20) repeatedly until PROT is shown in the display (27). When you press the ENTER key the currently used DMX profile is displayed. Use the keys + (19) or - (20) to select a value from P.001 to P.015 and confirm your selection with the ENTER key (18). The DMX profile is now selected and flashes three times.

Press the FUNCT key (17) three times to leave this menu level.

5.1.11 Turning on-board control lights on/off

In order to turn the lights at the on-board control on or off you have to navigate to menu level 3. To get there, proceed as follows:

Press the keys + (19) or - (20) repeatedly until SETUP is displayed in the left lower corner of the display (27).

Confirm with the ENTER key (18). Press the key + (19) or - (20) repeatedly until INDC is shown in the display (27). When you press the ENTER key, the current settings are displayed. Use the + (19) or - (20) keys to select either ON or OFF and confirm with ENTER (18). The light on the display (26) and LED signals (15 and 16) are now turned on or off. Press the FUNCT key (17) twice to leave this menu level.

5.1.12 Status request

In order to request the status via the on-board control proceed as follows:

a) Read operating hours

Press the keys + (19) or - (20) repeatedly until SETUP is displayed in the left lower corner of the display (27).

Confirm with the ENTER key (18). Press the key + (19) or - (20) repeatedly until HOUR is shown in the display (27). When you press the ENTER key the operating hours are displayed (e.g. 501 t). Press the FUNCT key (17) three times to leave this menu level.

b) Read DMX version

Press the keys + (19) or - (20) repeatedly until SETUP is displayed in the left lower corner of the display (27).

Confirm with the ENTER key (18). Press the key + (19) or - (20) repeatedly until DMXV is shown in the display (27). When you press the ENTER key the version is displayed (e.g. 3.1). Press the FUNCT key (17) three times to leave this menu level.

c) Read software version

Press the keys + (19) or - (20) repeatedly until SETUP is displayed in the left lower corner of the display (27).

Confirm with the ENTER key (18). Press the key + (19) or - (20) repeatedly until SW is shown in the display (27). When you press the ENTER key the version is displayed (e.g. 1.70.0). Press the FUNCT key (17) three times to leave this menu level.

d) Read operating temperature

Press the keys + (19) or - (20) repeatedly until SETUP is displayed in the left lower corner of the display (27).

Confirm with the ENTER key (18). Press the key + (19) or - (20) repeatedly until the temperature (e.g. 42.1°) is shown in the display (27). Press the FUNCT key (17) twice to leave this menu level.

e) Read availability

Press the keys + (19) or - (20) repeatedly until SETUP is displayed in the left lower corner of the display (27).

Confirm with the ENTER key (18). In the display (27) you can see OK or an error code (e.g. E.004 / see table with error messages on next page). Press the FUNCT key (17) twice to leave this menu level

5.1.13 Error messages

Code	Error	Solution
E.003	Controller over temperature	Let the lamphead cool down. After that the status LED should light up Green again. The lamphead is available for operation. Set the fader to 0 and then set the desired value.
E.004	Light Engine over temperature	See solution for E.003
E.005	Power supply over temperature	See solution for E.003
E.006	Calibration data faulty or read error of light engine memory	NOTICE: Loss of calibration data can only be solved in the factory. (You might have to exchange the light engine and carry out calibration again.)
E.007	Invalid PWM value calculation	This merely serves as a notification that a fault has occurred during calculation.
E.008	Invalid values during calculating step 1	See solution for E.007
E.009	Invalid values during calculating step 2	See solution for E.007
E.010	Fan error. Exceeding deviation from pre-set speed or fan outage. This error can only be detected in fans with speed indicator (3 wire fan).	CAUTION: Only a trained service person is allowed to fix this error! Set the fan to LOW or HI and see if it starts rotating, in order to determine if there is an electrical malfunction. All mechanical tests or repairs may only be carried out by a trained service technician.
From SW version 1.72.0		
E.011	On-board control could not be detected, or on-board control ID has not been programmed at the lamphead.	If the on-board control is working, error E.011 can be ignored. However, if the on-board control remains dark (no LED lights up) we recommend contacting a service partner. They can then carry out detailed analyses.
E.012	Temperature sensor(s) are defective or deviation within NTC values too high.	One or more temperature sensors are defective or the deviation within the individual NTCs or BNTCs exceeds the variation tolerance of 54° F. Check the error log (L-Series Manager) to see which temperature sensors are affected. Ask your service partner to fix this error.

5.1.14 Short-Cuts

From firmware version 1.74.1 the demo mode, setting the DMX address and the DMX protocol may be called up using short-cuts. To activate a short-cut:

- Press and hold ENTER, until JUMP appears in the display (from every menu).
- Press and hold FUNCT to activate the demo mode, pressing FUNCT again deactivates the demo mode.
- Press PLUS: Setting the DMX address.
- Press MINUS: Setting the DMX protocol.

JUMP disappears after 3 s without pressing a button or after pressing ENTER again.

Demo mode:

In demo mode the fixture calls up a loop:

- L7-T: Dimmer sequence. Choose the speed with the dimmer knob from slow (60 s per loop) to fast (1 s per loop).
- L7-TT and DT: Color temperature chase from warm to cold and back. The dimmer knob controls the brightness, the CCT knob controls the speed (60s – 1s per loop).
- L7-C: Color chase and color temperature chase. The dimmer knob controls the brightness. The CCT knob controls the speed (60s – 1s per loop). The GN knob is used to control the saturation of the colors or to switch to color temperature chase. With GN at "0" the color temperature chase is active. Turning the knob clockwise increases the saturation up to 100%.

Pressing JUMP and FUNCT or FUNCT alone deactivates the demo mode. The demo mode can be activated and deactivated using the menu Setup -> DEMO either.

Shift key:

This short-cut is only available in the main menu. Press ENTER, until a small arrow starts blinking in the display. Memory 1 or memory 2 calls up one of two factory settings.

All short-cuts are only available on fixtures with onboard control.

5.2 Settings options via DMX

5.2.1 DMX profile

The ARRI L7 range offers 15 DMX profiles, which can be pre-configured by the user. The 8-bit modes should be used with basic DMX control consoles (dimming consoles). The most common modes for operation are mode 01 and mode 02. ARRI recommends the use of the 16-bit mode in combination with a DMX control console, which supports functions up to 16-bit resolution in order to obtain premium results. The increased resolution over the 8-bit mode provides even smoother dimming and continuous color adjustment. Additionally there is a „Coarse/fine“ mode which allows you to perform a coarse and fine adjustment with two individual DMX channels. The Coarse / Fine modes utilize two DMX channels for most parameters and provide increased resolution over the 8-bit modes for users without 16-bit compatible control consoles. In case of a failure of the DMX signal the last valid DMX value will be retained. The setting can be changed at any time with the rotary knobs at the on-board control.

White and RGBW:

This is the most common mode of operation. It provides control over intensity, color temperature, +/- Green, and individual Red, Green, Blue, and White color channels.

White:

Simplified White-only mode for use when the number of available channels on a DMX control board is limited. It provides control over intensity, color temperature, and +/- Green.

White & HSI:

Provides control over intensity, color temperature, +/- Green, color hue, and color saturation. HSI = Hue, Saturation, Intensity. The advantage of HSI compared with RGBW is, that colors and intensity are exactly the same in each lamphead due to the applied color algorithms.

RGBW:

Simplified White-only mode for use when the number of available DMX channels is limited. It provides control over intensity and individual Red, Green, Blue, and White color channels.

HSI:

Simplified Hue, Saturation and Intensity mode for use when the number of available channels on a DMX control board is limited.

Note: For DMX Implementation Table see page 15 to 20 or <http://www.arri.com/l-series/downloads>

Note: Depending on the selected DMX profile the channels required for each lamphead should be allocated, if necessary up to 16 channels (required for DMX protokoll mode 6) right away.

5.2.2 DMX In / Pin allocation

5-pin-XLR (female connector)

pin 1 : ground (screen)

pin 2 : signal (-)

pin 3 : signal (+)

pin 4 : not used

pin 5 : not used

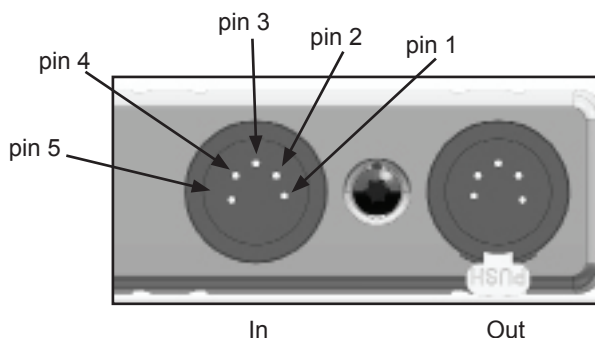

5.2.3 DMX IMPLEMENTATION TABLE V3.3
Available DMX Modes

fixture type	8 Bit Modes	16 Bit Modes	Coarse / Fine Modes
	1 DMX channel per function required	2 DMX channels per function required	1-2 DMX channels per function required
L7-T	01 - Dimm 8 *	02 - Dimm 16	03 - Dimm C/F (Coarse/Fine)
L7-DT	01 - White 8 Bit	02 - White 16 Bit	03 - White C/F
L7-TT	01 - White 8 Bit	02 - White 16 Bit	03 - White C/F
L7-C	01 - White & RGBW 8 Bit *	06 - White & RGBW 16 Bit	11 - White & RGBW C/F
	02 - White 8 Bit	07 - White 16 Bit	12 - White C/F
	03 - White & HSI 8 Bit	08 - White & HSI 16 Bit	13 - White & HSI C/F
	04 - RGBW 8 Bit	09 - RGBW 16 Bit	14 - RGBW C/F
	05 - HSI 8 Bit	10 - HSI 16 Bit	15 - HSI C/F
* standard modes (factory settings)			

L7-T Mode 01 - DIMM 8 BIT

channel no.	function	DMX value	output value	steps per bit	unit	notes
1	intensity	000 ... 255	0 ... 100	0,3922	%	

L7-T Mode 02 - DIMM 16 BIT

channel no.	function	DMX value	output value	steps per bit	unit	notes
1	intensity	00000 ... 65535	0 ... 100	0,0015	%	
2						

L7-T Mode 03 - DIMM C/F

channel no.	function	DMX value	output value	steps per bit	unit	notes
1	intensity	000 ... 255	0 ... 100	0,3922	%	
2	intensity (fine)	000 ... 255	0 ... 10	0,0392	%	

L7-DT Mode 01 - White 8 BIT

channel no.	function	DMX value	output value	steps per bit	unit	notes
1	intensity	000 ... 255	0 ... 100	0,3922	%	
2	color temperature	000 ... 255	5.000 ... 6.500	5,88	K	
3	green / magenta value	000 ... 010	neutral / no effect	-		
		011 ... 020	full minusgreen	-		
		021 ... 119	-99 ... -1	1	% GN	(1)
		120 ... 145	neutral / no effect	-		
		146 ... 244	1 ... 99	1	% GN	(1)
245 ... 255	full plusgreen	-				

L7-DT Mode 02 - White 16 BIT

channel no.	function		DMX value	output value	steps per bit	unit	notes
1	intensity	HI	00000 ... 65535	0 ... 100	0,0015	%	
2		LO					
3	color temperature	HI	00000 ... 65535	5.000 ... 6.500	0,0229	K	
4		LO					
5	green / magenta value	HI	00000 ... 05000	neutral / no effect	-	% GN	(1)
			05001 ... 10000	full minusgreen	-		
			10001 ... 29999	-99.995 ... -0.005	0.005		
6		LO	30000 ... 40000	neutral / no effect	-		
			40001 ... 59999	0.005 ... 99.995	0.005		
			60000 ... 65535	full plusgreen	-		

L7-DT Mode 03 - White C/F

channel no.	function		DMX value	output value	steps per bit	unit	notes
1	intensity		000 ... 255	0 ... 100	0,3922	%	
2	intensity (fine)		000 ... 255	0 ... 10	0,0392	%	
3	color temperature		000 ... 255	5.000 ... 6.500	5,88	K	
4	color temperature (fine)		000 ... 255	0 ... 255	1	K	
5	green / magenta value		000 ... 010	neutral / no effect	-	% GN	(1)
			011 ... 020	full minusgreen	-		
			021 ... 119	-99 ... -1	1		
			120 ... 145	neutral / no effect	-		
			146 ... 244	1 ... 99	1		
			245 ... 255	full plusgreen	-		

L7-TT Mode 01 - White 8 BIT

channel no.	function		DMX value	output value	steps per bit	unit	notes
1	intensity		000 ... 255	0 ... 100	0,3922	%	
2	color temperature		000 ... 255	2.600 ... 3.600	3,92	K	
3	green / magenta value		000 ... 010	neutral / no effect	-	% GN	(1)
			011 ... 020	full minusgreen	-		
			021 ... 119	-99 ... -1	1		
			120 ... 145	neutral / no effect	-		
			146 ... 244	1 ... 99	1		
			245 ... 255	full plusgreen	-		

L7-TT Mode 02 - White 16 BIT

channel no.	function		DMX value	output value	steps per bit	unit	notes
1	intensity	HI	00000 ... 65535	0 ... 100	0,0015	%	
2		LO					
3	color temperature	HI	00000 ... 65535	2.600 ... 3.600	0,0153	K	
4		LO					
5	green / magenta value	HI	00000 ... 05000	neutral / no effect	-	% GN	(1)
			05001 ... 10000	full minusgreen	-		
			10001 ... 29999	-99.995 ... -0.005	0.005		
6		LO	30000 ... 40000	neutral / no effect	-		
			40001 ... 59999	0.005 ... 99.995	0.005		
			60000 ... 65535	full plusgreen	-		

L7-TT Mode 03 - White C/F

channel no.	function	DMX value	output value	steps per bit	unit	notes
1	intensity	000 ... 255	0 ... 100	0,3922	%	
2	intensity (fine)	000 ... 255	0 ... 10	0,0392	%	
3	color temperature	000 ... 255	2.600 ... 3.600	3,92	K	
4	color temperature (fine)	000 ... 255	0 ... 255	1	K	
5	green / magenta value	000 ... 010	neutral / no effect	-		
		011 ... 020	full minusgreen	-		
		021 ... 119	-99 ... -1	1	% GN	(1)
		120 ... 145	neutral / no effect	-		
		146 ... 244	1 ... 99	1	% GN	(1)
		245 ... 255	full plusgreen	-		

L7-C Mode 01 - White & RGBW 8 BIT

channel no.	function	DMX value	output value	steps per bit	unit	notes
1	master intensity	000 ... 255	0 ... 100	0.3922	%	
2	color temperature	000 ... 255	2,800 ... 10,450	30	K	
3	green / magenta value	000 ... 010	neutral / no effect	-		
		011 ... 020	full minusgreen	-		
		021 ... 119	-99 ... -1	1	% GN	(1)
		120 ... 145	neutral / no effect	-		
		146 ... 244	1 ... 99	1	% GN	(1)
		245 ... 255	full plusgreen	-		
4	white-color crossfade	000 ... 255	0 ... 100	0.3922	%	(2)
5	red intensity	000 ... 255	0 ... 100	0.3922	%	
6	green intensity	000 ... 255	0 ... 100	0.3922	%	
7	blue intensity	000 ... 255	0 ... 100	0.3922	%	
8	white intensity	000 ... 255	0 ... 100	0.3922	%	

L7-C Mode 02 - White 8 BIT

channel no.	function	DMX value	output value	steps per bit	unit	notes
1	intensity	000 ... 255	0 ... 100	0.3922	%	
2	color temperature	000 ... 255	2,800 ... 10,400	30	K	
3	green / magenta value	000 ... 010	neutral / no effect	-		
		011 ... 020	full minusgreen	-		
		021 ... 119	-99 ... -1	1	% GN	(1)
		120 ... 145	neutral / no effect	-		
		146 ... 244	1 ... 99	1	% GN	(1)
		245 ... 255	full plusgreen	-		

L7-C Mode 03 - White & HSI 8 BIT

channel no.	function	DMX value	output value	steps per bit	unit	notes	
1	master intensity	000 ... 255	0 ... 100	0.3922	%		
2	color temperature	000 ... 255	2,800 ... 10,450	30	K		
3	green / magenta value	000 ... 010	neutral / no effect	-1	-	% GN (1)	
		011 ... 020	full minusgreen		-		
		021 ... 119	-99		1		
		120 ... 145	neutral / no effect		-		
		146 ... 244	1		1		% GN (1)
		245 ... 255	full plusgreen		-		
4	white-color crossfade	000 ... 255	0 ... 100	0.3922	%	(2)	
5	hue	000 ... 255	0 ... 360	1.4118	°		
6	saturation	000 ... 255	0 ... 100	0.3922	%		

L7-C Mode 04 - RGBW 8 BIT

channel no.	function	DMX value	output value	steps per bit	unit	notes
1	master intensity	000 ... 255	0 ... 100	0.3922	%	
2	red intensity	000 ... 255	0 ... 100	0.3922	%	
3	green intensity	000 ... 255	0 ... 100	0.3922	%	
4	blue intensity	000 ... 255	0 ... 100	0.3922	%	
5	white intensity	000 ... 255	0 ... 100	0.3922	%	

L7-C Mode 05 - HSI 8 BIT

channel no.	function	DMX value	output value	steps per bit	unit	notes
1	intensity	000 ... 255	0 ... 100	0.3922	%	
2	hue	000 ... 255	0 ... 360	1.4118	°	
3	saturation	000 ... 255	0 ... 100	0.3922	%	

L7-C Mode 06 - White & RGBW 16 BIT

channel no.	function	DMX value	output value	steps per bit	unit	notes		
1	master intensity	HI	0 ... 100	0.001529	%			
2		LO						
3	color temperature	HI	2,800 ... 10,450	0.1167	K			
4		LO						
5	green / magenta value	00000 ... 05000	neutral / no effect	-0.005	-	% GN (1)		
		05001 ... 10000	full minusgreen		-			
		10001 ... 29999	-99.995		0.005			
6		LO	30000 ... 40000		neutral / no effect		-	
			40001 ... 59999		0.005		0.005	% GN (1)
			60000 ... 65535		full plusgreen		-	
7	white-color crossfade	HI	0 ... 100	0.001529	%	(2)		
8		LO						
9	red intensity	HI	0 ... 100	0.001529	%			
10		LO						
11	green intensity	HI	0 ... 100	0.001529	%			
12		LO						
13	blue intensity	HI	0 ... 100	0.001529	%			
14		LO						
15	white intensity	HI	0 ... 100	0.001529	%			
16		LO						

L7-C Mode 07 - White 16 BIT

channel no	function		DMX value	output value	steps per bit	unit	notes	
1	intensity	HI	00000 ... 65535	0 ... 100	0.001529	%		
2		LO						
3	color temperature	HI	00000 ... 65535	2,800 ... 10,450	0.1167	K		
4		LO						
5	green / magenta value	HI	00000 ... 05000	neutral / no effect	...	-0.005	0.005	% GN (1)
			05001 ... 10000	full minusgreen				
			10001 ... 29999	-99.995				
6		LO	30000 ... 40000	neutral / no effect	...	99.995	0.005	% GN (1)
			40001 ... 59999	0.005				
			60000 ... 65535	full plusgreen				

L7-C Mode 08 - White & HSI 16 BIT

channel no	function		DMX value	output value	steps per bit	unit	notes	
1	master intensity	HI	00000 ... 65535	0 ... 100	0.001529	%		
2		LO						
3	color temperature	HI	00000 ... 65535	2,800 ... 10,450	0.1167	K		
4		LO						
5	green / magenta value	HI	00000 ... 05000	neutral / no effect	...	-0.005	0.005	% GN (1)
			05001 ... 10000	full minusgreen				
			10001 ... 29999	-99.995				
6		LO	30000 ... 40000	neutral / no effect	...	99.995	0.005	% GN (1)
			40001 ... 59999	0.005				
			60000 ... 65535	full plusgreen				
7	white-color crossfade	HI	00000 ... 65535	0 ... 100	0.001529	%	(2)	
8		LO						
9	hue	HI	00000 ... 65535	0 ... 360	0.005493	°		
10		LO						
11	saturation	HI	00000 ... 65535	0 ... 100	0.001529	%		
12		LO						

L7-C Mode 09 - RGBW 16 BIT

channel no	function		DMX value	output value	steps per bit	unit	notes
1	master intensity	HI	00000 ... 65535	0 ... 100	0.001529	%	
2		LO					
3	red intensity	HI	00000 ... 65535	0 ... 100	0.001529	%	
4		LO					
5	green intensity	HI	00000 ... 65535	0 ... 100	0.001529	%	
6		LO					
7	blue intensity	HI	00000 ... 65535	0 ... 100	0.001529	%	
8		LO					
9	white intensity	HI	00000 ... 65535	0 ... 100	0.001529	%	
10		LO					

L7-C Mode 10 - HSI 16 BIT

channel no	function		DMX value	output value	steps per bit	unit	notes
1	intensity	HI	00000 ... 65535	0 ... 100	0.001529	%	
2		LO					
3	hue	HI	00000 ... 65535	0 ... 360	0.005493	°	
4		LO					
5	saturation	HI	00000 ... 65535	0 ... 100	0.001529	%	
6		LO					

L7-C Mode 11 - White & RGBW C/F

channel no.	function	DMX value	output value	steps per bit	unit	notes
1	master intensity	000 ... 255	0 ... 100	0.3922	%	
2	master intensity (fine)	000 ... 255	0 ... 10	0.0392	%	
3	color temperature	000 ... 255	2,800 ... 10,450	30	K	
4	color temperature (fine)	000 ... 255	0 ... 255		K	
5	green / magenta value	000 ... 010	neutral / no effect	-1	-	% GN (1)
		011 ... 020	full minusgreen		-	
		021 ... 119	-99		1	
		120 ... 145	neutral / no effect		-	
		146 ... 244	1		1	
		245 ... 255	full plusgreen		-	
6	white-color crossfade	000 ... 255	0 ... 100	0.3922	%	(2)
7	red intensity	000 ... 255	0 ... 100	0.3922	%	
8	red intensity (fine)	000 ... 255	0 ... 10	0.0392	%	
9	green intensity	000 ... 255	0 ... 100	0.3922	%	
10	green intensity (fine)	000 ... 255	0 ... 10	0.0392	%	
11	blue intensity	000 ... 255	0 ... 100	0.3922	%	
12	blue intensity (fine)	000 ... 255	0 ... 10	0.0392	%	
13	white intensity	000 ... 255	0 ... 100	0.3922	%	
14	white intensity (fine)	000 ... 255	0 ... 10	0.0392	%	

L7-C Mode 12 - White C/F

channel no.	function	DMX value	output value	steps per bit	unit	notes
1	intensity	000 ... 255	0 ... 100	0.3922	%	
2	intensity (fine)	000 ... 255	0 ... 10	0.0392	%	
3	color temperature	000 ... 255	2,800 ... 10,450	30	K	
4	color temperature (fine)	000 ... 255	0 ... 255		K	
5	green / magenta value	000 ... 010	neutral / no effect	-1	-	% GN (1)
		011 ... 020	full minusgreen		-	
		021 ... 119	-99		1	
		120 ... 145	neutral / no effect		-	
		146 ... 244	1		1	
		245 ... 255	full plusgreen		-	

L7-C Mode 13 - White & HSI C/F

channel no.	function	DMX value	output value	steps per bit	unit	notes
1	master intensity	000 ... 255	0 ... 100	0.3922	%	
2	master intensity (fine)	000 ... 255	0 ... 10	0.0392	%	
3	color temperature	000 ... 255	2,800 ... 10,450	30	K	
4	color temperature (fine)	000 ... 255	0 ... 255	1	K	
5	green / magenta value	000 ... 010	neutral / no effect		-	% GN (1)
		011 ... 020	full minusgreen		-	
		021 ... 119	-99	... -1	1	
		120 ... 145	neutral / no effect		-	
		146 ... 244	1		... 99	
		245 ... 255	full plusgreen	-		
6	white-color crossfade	000 ... 255	0 ... 100	0.3922	%	(2)
7	hue	000 ... 255	0 ... 360	1.4118	°	
8	hue (fine)	000 ... 255	0 ... 25.5	0.100	°	
9	saturation	000 ... 255	0 ... 100	0.3922	%	
10	saturation (fine)	000 ... 255	0 ... 10	0.0392	%	

L7-C Mode 14 - RGBW C/F

channel no.	function	DMX value	output value	steps per bit	unit	notes
1	master intensity	000 ... 255	0 ... 100	0.3922	%	
2	master intensity (fine)	000 ... 255	0 ... 10	0.0392	%	
3	red intensity	000 ... 255	0 ... 100	0.3922	%	
4	red intensity (fine)	000 ... 255	0 ... 10	0.0392	%	
5	green intensity	000 ... 255	0 ... 100	0.3922	%	
6	green intensity (fine)	000 ... 255	0 ... 10	0.0392	%	
7	blue intensity	000 ... 255	0 ... 100	0.3922	%	
8	blue intensity (fine)	000 ... 255	0 ... 10	0.0392	%	
9	white intensity	000 ... 255	0 ... 100	0.3922	%	
10	white intensity (fine)	000 ... 255	0 ... 10	0.0392	%	

L7-C Mode 15 - HSI C/F

channel no.	function	DMX value	output value	steps per bit	unit	notes
1	Intensität	000 ... 255	0 ... 100	0.3922	%	
2	Intensität (fein)	000 ... 255	0 ... 10	0.0392	%	
3	Farbton	000 ... 255	0 ... 360	1.4118	°	
4	Farbton (fein)	000 ... 255	0 ... 25.5	0.100	°	
5	Sättigung	000 ... 255	0 ... 100	0.3922	%	
6	Sättigung (fein)	000 ... 255	0 ... 10	0.0392	%	

Remarks:

(1)	"%GN" means the percentage of shift between the neutral color point and the full minusgreen resp. full plusgreen color points derived from Rosco Cinegel gels #3304 resp. #3308.
(2)	"crossfade" means the percentage of shift from the programmed white color point to the programmed RGBW or HSI color point.

5.2.4 Conversion of CCT value to DMX %

You can convert the CCT value to DMX % (or the other way around) with the following formula:

$$\text{CCT-value} = (\text{CCTmax} - \text{CCTmin}) \times (\text{DMX-value in \%}) / (100 + \text{CCTmin})$$

$$\text{DMX-value in \%} = (\text{CCT-value} - \text{CCTmin}) / (\text{CCTmax} - \text{CCTmin}) \times 100$$

 L7-C: CCTmin = 2800
 CCTmax = 10000

 L7-TT: CCTmin = 2600
 CCTmax = 3600

 L7-DT: CCTmin = 5000
 CCTmax = 6500

The RDM functions listed below are supported from SW version 1.66.08

RDM standard commands:

Command (English)	Description	GET	SET
Discover Unique Branch	Searches RDM device	yes	yes
Discover Mute	Mutes the RDM device, no response messages	yes	yes
Discover Unmute	Activates device for response messages	yes	yes
Supported Parameters	Shows a list of all supported RDM commands	yes	
Parameter Description	Shows a list of commands that are not standard rdm commands, mostly commands from manufacturer. Describes the data type and shows if Set or Get or both are supported for the listed commands.	yes	
Device Info	Lists RDM protocol version, device model ID, product category, software version ID (from Main), DMX footprint, DMX personality, sub-device count and sender count	yes	
Software Version Label	Shows the software version string from main, e.g. Main 1.66.1 Yesn 16 2012 19:10:26	yes	
DMX Start Address	DMX address	yes	yes
Identify Device	Identify Flag -> physically flash the light, L7-C flashes Blue and all other White	yes	yes
Required RDM command extensions			
Status Message	Display of actual warning / error message of the fixture	yes	
Status ID Description	Detailed description of each warning / status report	yes	
Device Label	This parameter allows you to generate an informative label for each fixture. It can be utilized to identify the rack number of a dimmer or to determine the position of a fixture	yes	yes
Product Detail ID List	This parameter is utilized to retrieve technical details of a fixture. L7 shows LED with PWM control	yes	
Device Model Description	A text description of up to 32 characters for the model type of the fixture. L7 shows L7-C or L7-T	yes	
Manufacturer Label	Display the company name ARRI Lighting		
Boot Software Version ID	PrBo SW Version 2.03.00	yes	
Boot Software Version Label	Shows text from PrBo Bootloader, e.g. PrBo 2.03.00 Jan 16 2012 19:10:26	yes	
DMX Personality	DMX mode	yes	yes
DMX Personality Description	Displays a text description of a DMX mode with up to 32 characters, shown exactly as in the description in the LS-Manager	yes	
Slot Info	Shows a description for each DMX channel in use in the requested DMX mode	yes	

Command (English)	Description	GET	SET
Slot Description	Shows a text description with max. 32 characters for each DMX channel from the requested DMX mode	yes	
Default Slot Value	Shows the default DMX channel value from the requested DMX mode	yes	
Sensor Definition	Shows the definition from a specific sensor and a text description	yes	
Sensor Value	Shows the actual sensor value	yes	
Device Hours	Shows the actual device hours of the fixture	yes	
Lamp Hours	Shows the actual lamp hours of the fixture	yes	
Factory Defaults	This command deletes all user parameters and sets the fixture to factory default	yes	yes
Device Power Cycles	Shows the power cycle value, counts every cold start (switch or power-up)	yes	
Reset Device	Fixture makes a software reset (warm start) and carries out a reboot	yes	yes
Power State	Power state of the fixture, supported power states: POWER_STATE_STANDBY (0x02), POWER_STATE_NORMAL (0xFF), POWER_STATE_FULL_OFF (0x00) POWER_STATE_SHUTDOWN (0x01)	yes	yes
Perform Selftest	Supported test modes and demo modes	yes	yes
Self Test Description	Shows a description for each test / demo mode	yes	

Manufacturer commands			
Command (English)	Description	GET	SET
RDM Fan Mode PID:0x8001	Changes the FAN mode of the fixture - this message supports Set and Get commands - the first data byte is used to show / change the fan mode hybrid: USER_FAN_MODE_OFF = 0 USER_FAN_MODE_LOW = 1 USER_FAN_MODE_HIGH = 2 USER_FAN_MODE_AUTO_LOW = 3 USER_FAN_MODE_AUTO_HIGH = 4 USER_FAN_MODE_VARI = 5 USER_FAN_MODE_PASS = 6 active: USER_FAN_MODE_LOW = 1 USER_FAN_MODE_VARI = 2 USER_FAN_MODE_HI45 = 3		
RDM Status LED PID:0x8002	Switch on /off indication LEDs and LCD back light - this message supports Set and Get commands - the first data byte is used to switch indication LEDs on and off LEDs and LCD back light on = 0 LEDs and LCD back light off = 1		
Supported values from -1 to +1			
RDM DMX Signal Lost Mode PID:0x8005	If the DMX signal gets lost or the DMX device is unplugged the LED fixture holds the last valid signal, or it holds the last valid signal for two minutes and then dimms or switches off immediately. Supported values: 0 -> hold 1 -> hold 2 minutes 3 -> switch off	yes	yes

5.3 LSeries Manager

The LSManager software bundle which can be downloaded from the ARRI web site free of charge contains an instruction manual for the LSManager software. Please find a detailed description of the functionality in this manual.

6. Technical Data

Specifications of the L7 range	
Optical system	focussable Fresnel
Lens diameter	175 mm / 7 Inch
Beam angle	15° - 50° (half peak angle)
Handling	Adjustable sliding stirrup, high strength tilt lock, pole operation optional (pan, tilt and focus)
Mounting	28 mm / 1,10 Inch spigot
Tilt angle	+/- 90°
Power supply range	90 - 264V AC, 50-60Hz
Replaceable fuse	2,5A flink "F", breaking capacity: 1500A and 250V AC, size: 5x20 mm / 0,196x0,787 Inch
Power consumption	220 W maximum
Power connection	Bare ends / Schuko / Edison Connector
Dimming	0 -100% continuous
Control	5-Pin DMX „In and Through“, Optional on-board controller, Mini-USB
Remote Device Management (RDM)	DMX functions, hour counter and standard RDM commands
Mini-USB interface	DMX functions, fixture status and firmware upgrade through PC software
Housing colors	Blue-silver, black
Estimated LED lifetime (L70)	50,000 hours
Certifications	CE, GS, FCC, cNRTL, CB, ISO9001:2000
All specifications are nominal / typical values.	

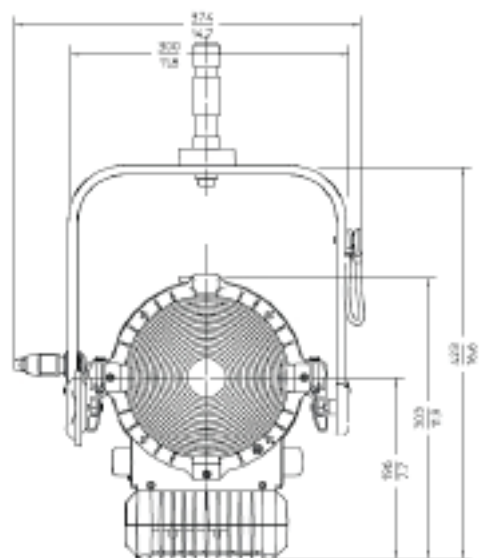
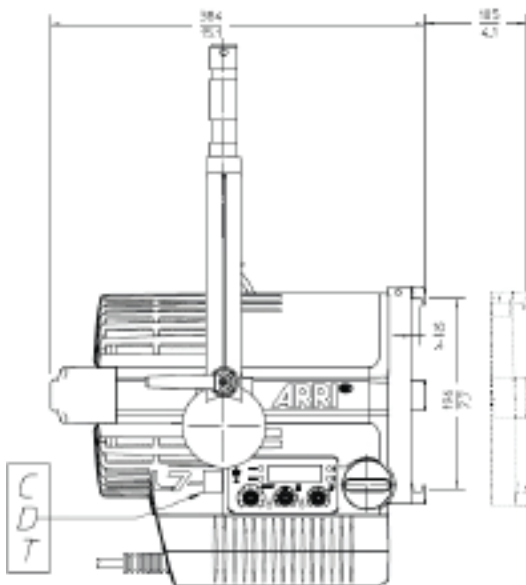

Individual specifications				
Lamphead type	L7-C hybrid	L7-DT hybrid	L7-TT hybrid	L7-T hybrid
Weight	10.9 kg / 24 lb (hanging / stand), 12.5 kg / 27 lb (pole operation)	10.9 kg / 24 lb (hanging / stand), 12.5 kg / 27 lb (pole operation)	10.9 kg / 24 lb (hanging / stand), 12.5 kg / 27 lb (pole operation)	10.9 kg / 24 lb (hanging / stand), 12.5 kg / 27 lb (pole operation)
White light	Continuously variable correlated color temperature from 2,800 K - 10,000 K	Continuously variable correlated color temperature from 5000 K - 6500 K	Continuously variable correlated color temperature from 2600 K - 3600 K	3200 K
Colored light	Full RGB+W gamut with hue and saturation control	-	-	-
Color rendition	CRI 95 (3,200 K - 6,500 K)	CRI 94	CRI 92	-
Green-Magenta adjustment	+/- 1/8 (nominal)	+/- 1/8 (nominal)	+/- 1/8 (nominal)	+/- 1/8 (nominal)
Ambient temperature operation	-20° - 35° C / -4° - 95° F	-20° - 35° C / -4° - 95° F	-20° - 35° C / -4° - 95° F	-20° - 35° C / -4° - 95° F
Protection class	IP 20	IP 20	IP 20	IP 20
All specifications are nominal / typical values.				

Individual specifications				
Lamphead type	L7-C aktiv	L7-DT aktiv	L7-TT aktiv	L7-T aktiv
Weight	8.2 kg / 18 lb (hanging / stand), 9.8 kg / 21.6 lb (pole operation)	8.2 kg / 24 lb (hanging / stand), 9.8 kg / 27 lb (pole operation)	8.2 kg / 24 lb (hanging / stand), 9.8 kg / 27 lb (pole operation)	8.2 kg / 18 lb (hanging / stand), 9.8 kg / 21.6 lb (pole operation)
White light	Continuously variable correlated color temperature from 2,800 K - 10,000 K	Continuously variable correlated color temperature from 5000 K - 6500 K	Continuously variable correlated color temperature from 2600 K - 3600 K	3200 K
Colored light	Full RGB+W gamut with hue and saturation control	-	-	-
Color rendition	CRI 95 (3,200 K - 6,500 K)	CRI 94	CRI 92	-
Green-Magenta adjustment	+/- 1/8 (nominal)	+/- 1/8 (nominal)	+/- 1/8 (nominal)	+/- 1/8 (nominal)
Ambient temperature operation	-20° - 45° C / -4° - 113° F	-20° - 45° C / -4° - 113° F	-20° - 45° C / -4° - 113° F	-20° - 45° C / -4° - 113° F
Protection class	IP 20	IP 20	IP 20	IP 20
All specifications are nominal / typical values.				

EC Declaration of Conformity

The appliances conform to the essential requirements and the further guidelines of directives 2004/108/EC (EMC) and 2006/95/EC (LVD).



Please visit our website if you should experience any technical problems.
You will also find a directory of our ARRI Service Centers there.

Visit our homepage for further information and to download our service tools.

www.arri.com