



## **THE LE SERIES**

**14x40mm Gyro-Stabilized Observer  
Engineered with STEDI-EYE® Technology**



**FRASER OPTICS** *The Clear Advantage*





## The LE Series 14x40mm Observer Engineered with STEDI-EYE® Technology

When conducting harbor patrol, aerial surveillance, reconnaissance or high-speed pursuits, Fraser Optics' LE Series 14x40mm Gyro-Stabilized Observer Binocular with Touch Pad Stabilization enables you to stay clearly focused on your target. Designed specifically for law enforcement and engineered using Fraser Optics' STEDI-EYE® Technology, our binocular enhances situational awareness by removing up to 98% of image motion caused by hand or platform movement. Ruggedized to withstand the most extreme operational and environmental conditions, our modular, MILSPEC device provides the proven, tested performance to support the most challenging of missions. When every second counts, the Observer offers the clear advantage.



**FRASER OPTICS**  
The Clear Advantage

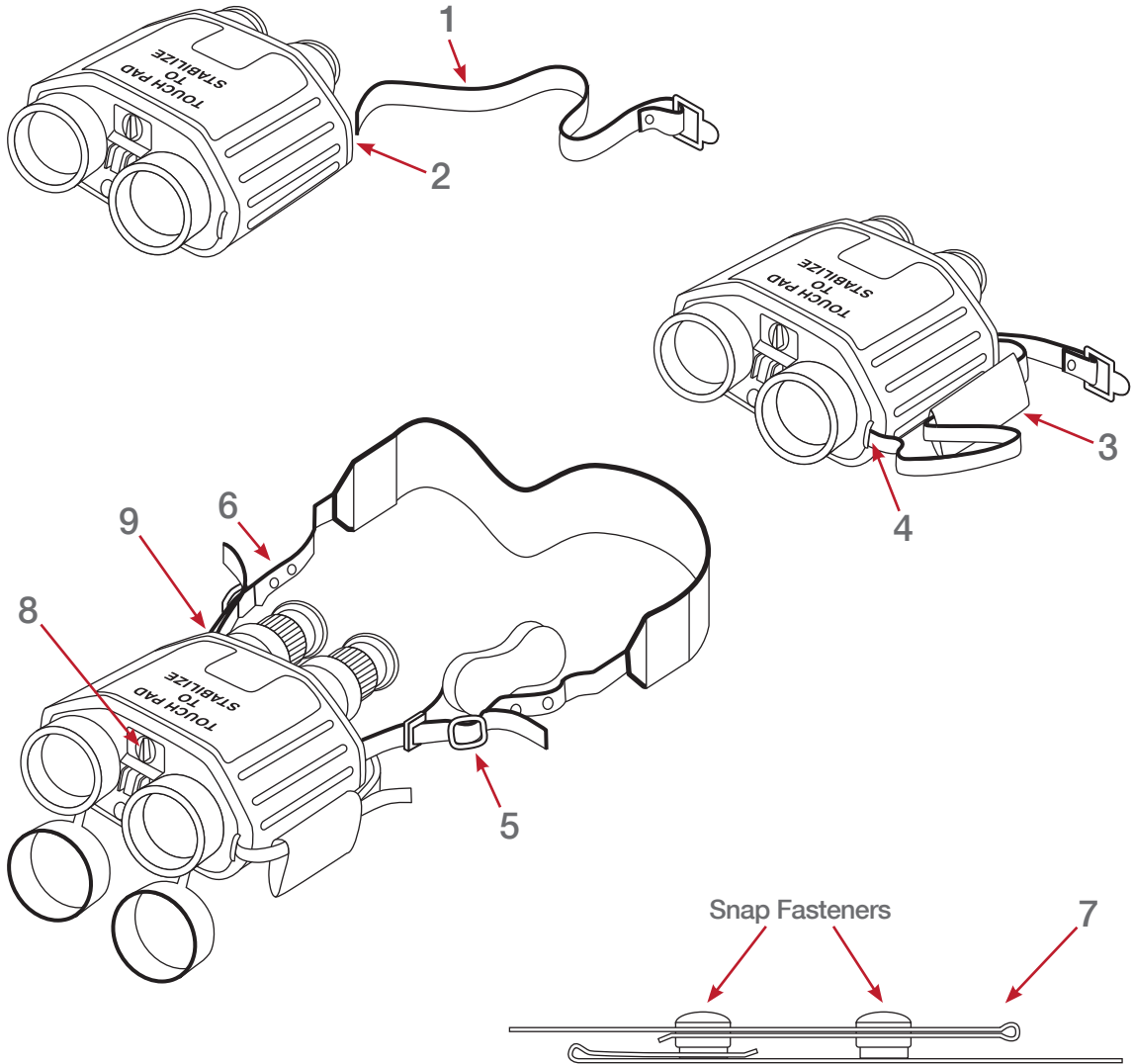

## Getting Started

1. Slide plain end of webbing strap (1) through eyepiece strap hook (2).  
NOTE: Hand strap may be installed on opposite side of the binocular for a left-handed user.
2. With exterior side of pad facing binocular, lace webbing strap through hand pad (3).  
Insert webbing strap under objective lens strap hook and pull webbing strap through strap hook. Webbing strap should not be pulled tight against binocular. Lace end of webbing strap securely through fastener (4). With webbing strap inside hand pad, fasten Velcro closure.
3. Using fasteners on webbing strap (5), adjust neck strap length so binocular hangs halfway between shoulders and waist. **WARNING:** The neck strap of the binocular may become tangled during an emergency. To facilitate quick removal, the neck strap incorporates a quick disconnect feature (6) activated by a pull release system (7).
4. Open battery cover (8) on the front of the stabilized binocular. Insert two new batteries in the orientation indicated on inside of battery cover and replace the battery cover.
5. Turn the control knob (9) to AUTO, activating the touch pad stabilization. Allow the motor to run for approximately 30 seconds to get to full speed.
6. Turn the control knob to LOCK, which provides solid state stabilization.



**FRASER OPTICS**  
*The Clear Advantage*

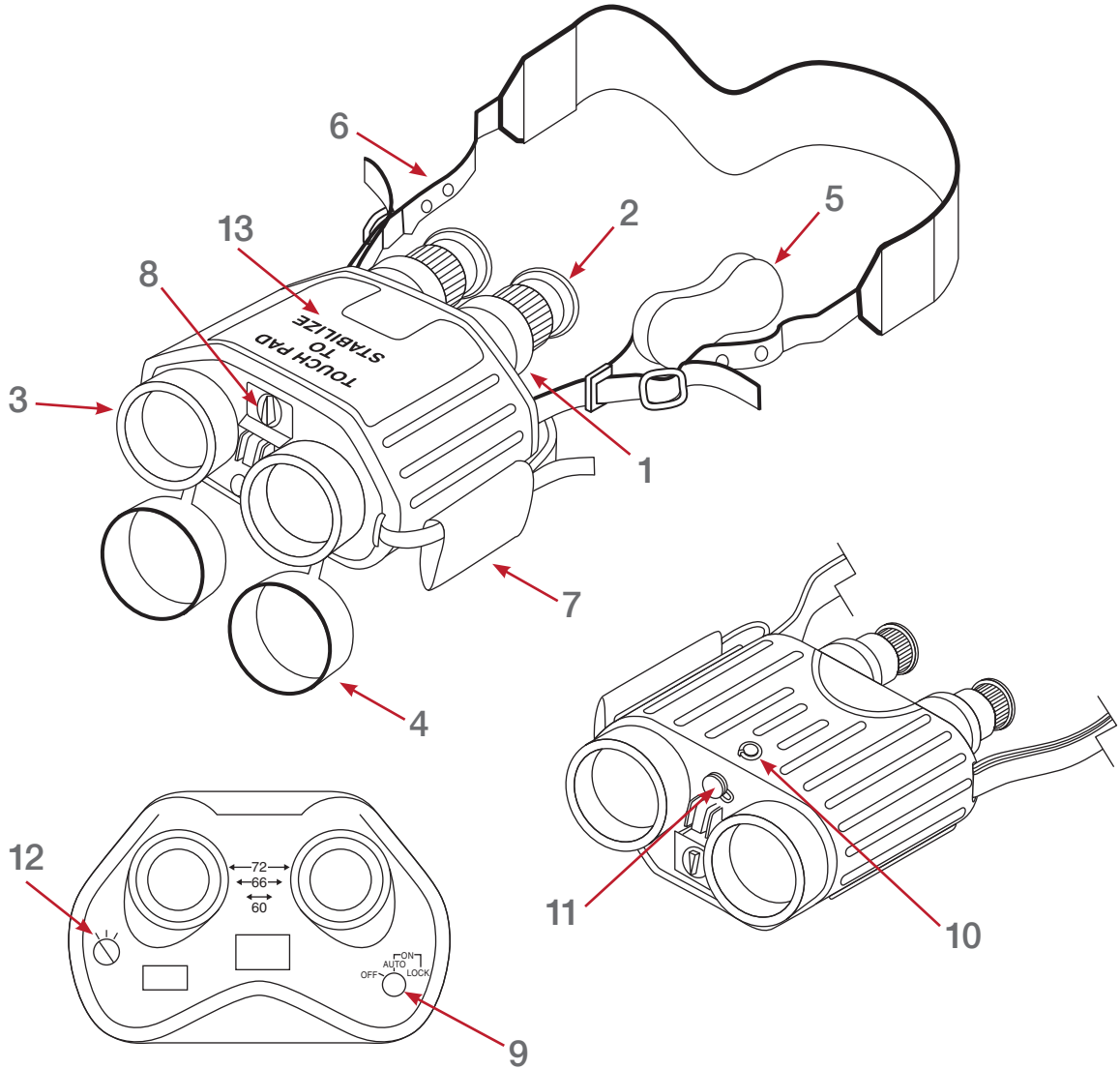

## Location and Description of Major Components

The LE Series 14x40mm Observer Binocular is gyroscopically stabilized. The gyro is driven electrically by a small motor, powered by two AA batteries or external power, in the range of 6 to 30 VDC. The Vehicle Power Cord adapter provides external power by connecting the unit to the vehicle cigarette lighter.

1. EYEPIECE. Two detachable pieces used to look through binocular. These adjust for individual diopter (focus) and eye spacing.
2. EYECUP. Rubber end on eyepiece. Folds back for viewing with eyeglasses.
3. OBJECTIVE LENS. Located on each side of battery box.
4. OBJECTIVE LENS CAP. Covers for protection of objective lens when stabilized binocular is not in use.
5. EYEPIECE LENS CAP. Cover for protection of eyepiece lenses when stabilized binocular is not in use.
6. NECK STRAP. Allows user to carry binocular around neck.
7. HAND STRAP. Adjustable to allow for easy operation with one hand.
8. BATTERY BOX. Houses two AA batteries required to supply power to use gyro-stabilization feature.
9. CONTROL KNOB. Turns the unit power on and activates stabilization.
10. TRIPOD MOUNTING HOLE. 1/4"-20 threaded hole located on the bottom of binocular for securing device to a tripod.
11. VEHICLE POWER CORD PORT. Connects to binocular for use with external power source.
12. BATTERY METER. Indicates battery power.
13. TOUCH PAD STABILIZATION. Used to activate stabilization.

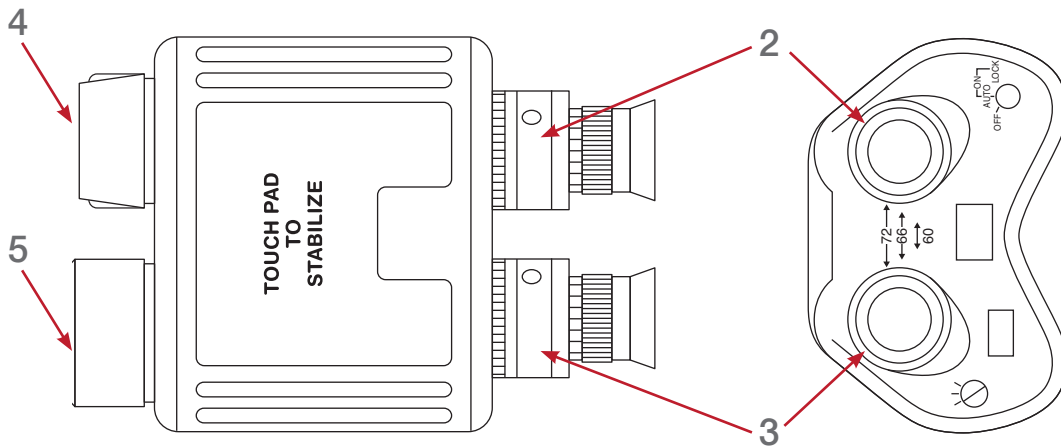
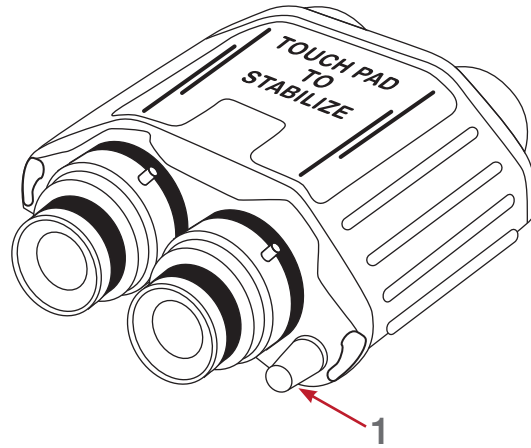



## Using Your Observer Binocular

### Option 1

1. Turn the power switch to AUTO.
2. Press and hold down the touchpad to uncage the gyro and activate stabilization.  
Release the touchpad to cage the gyro and deactivate stabilization.

### Option 2

1. Turn the power switch to the LOCK position to uncage the gyro and activate stabilization.
2. Turn the power switch to the AUTO position to cage the gyro and deactivate stabilization.

## To Focus Your Binocular

1. Set the Interpupillary Adjustment by holding the eyepieces (2 and 3) and manually moving them toward the center or outward, to accommodate the spacing of your eyes.
2. No further eye spacing adjustments should be needed during use of the device and the noted settings may be used for future initialization.
3. Remove the right lens cap (4), leaving the left one on.
4. Using the right eye, view through the right eyepiece (2) at a distant target.  
Slowly rotate the right eyepiece until the target is brought into sharp focus.
5. Replace the right lens cap and remove the left one (5).
6. Using the left eye, view through the left eyepiece (3) at the same distant target. Slowly rotate the left eyepiece until the target is brought into sharp focus.
7. Remove the right lens cap. The stabilized binocular is now focused for your eyes.

NOTE: Rotating the eyepiece further than necessary in the clockwise direction could reduce the depth of field that can be achieved without refocusing.

## Cleaning Procedures

### To clean the lenses:

- Using Fraser Optics retractable brush, remove as much dust and dirt as possible from the exposed lens surface.
- Brush across the surface with light, quick strokes, flicking after each stroke to dislodge the dust.
- When all visible particles of dust and dirt have been removed, use Fraser Optics lens cleaning solution or pre-moistened cleaning cloths and gently wipe over the surface.

**NOTE:** Anti-Fog Kit supplied with standard model does not contain the above items. The Advanced Lens Cleaning Kit sold separately does contain the items referenced.

**CAUTION:** Never wipe dry or dirty lenses with a dry cloth. Clean the exterior of the binocular (not the lenses) with a clean Fraser Optics microfiber cloth. Remove grease and soil with soap and water and a damp clean cloth. Dry with a clean, lint free cloth. Blow dirt and lint from case interiors.

## Equipment Specifications

Magnification .....	14x
Objective diameter.....	40mm
Exit pupil .....	3mm
Field of view (74m @ 1,000m) .....	4.3°
Resolution (day) .....	4.3 Arc seconds
Stabilization freedom.....	±8°
Focus adjustment .....	±5 diopters
Scan rate.....	8°/sec
Interpupillary adjustment .....	60-75mm
Power (internal).....	2 AA cells
Power (external) .....	6-30 VDC
Weight (day).....	4.5 lbs. (2.04kg)

## Dimensions

Length (day) .....	8.25" (210mm)
Width .....	7.5" (190mm)
Height.....	3.5" (89mm)

Environmental	Operational	Storage
High temperature	120° F (49° C)	160° F (71° C)
Low temperature	-25.6° F (-32° C)	-50.8° F (-46° C)
Waterproof	1 meter depth	N/A

## Troubleshooting Procedures

All internal maintenance on the Observer STEDI-EYE® stabilized binocular is to be accomplished by Fraser Optics. Opening binocular, or attempting any repair beyond that which is outlined in this manual, may void warranty and/or cause damage to, or degrade performance. If, after troubleshooting, there are deficiencies that cannot be corrected, please return to the manufacturer. Contact information is provided at the end of this manual.

<b>MALFUNCTION</b>	<b>TEST OR INSPECTION</b>	<b>CORRECTIVE ACTION</b>
Not functioning	1. Check to see if control knob is in the ON position.	Turn ON control knob.
	2. Inspect battery power indicator.	If battery power indicator shows red, replace batteries.
No battery power	1. Check to see if batteries are present.	If batteries are missing, install new batteries properly.
	2. Check for low or dead batteries.	Install new batteries properly.
	3. Check to see that batteries are properly installed.	Install batteries properly.
	4. Check to see if battery cap contact is bent, broken, or corroded.	Contact Fraser Optics.
	5. Failure to respond to items 1 through 4 above.	Contact Fraser Optics.

## Return for Service Instructions

If your Fraser Optics product fails to perform in any way, please contact a customer service representative by calling (215) 443-5240. If the product needs to be sent to Fraser Optics for service, the customer service representative will provide you with a repair number (RMA).

### **Please follow these steps when sending any product to Fraser Optics Product Service:**

1. Please remove the lens caps, mounts, straps, mounting rings, covers, and all other accessories from the product.
2. Record the serial number of the product and keep it where you can find it if needed.
3. Include a note with the product indicating a detailed reason the product is being sent and clearly print the repair number on the outside of the package.
4. Make certain that your name, shipping address, telephone number, and e-mail (if applicable) are included in the note.

If the product was purchased in the US, insure your product for the appropriate dollar value and send it to:

Fraser Optics  
c/o Product Service  
1025 Thomas Drive  
Warminster, PA 18974-2892

We will not be held liable for damages incurred to unit(s) during transit.

## Repair Process

When your unit is received, it will be evaluated to determine what repairs are needed and whether or not warranty coverage will be applicable. It is our option to repair or replace your unit. If your unit is covered under warranty, you will be notified via our customer service. If your unit is NOT covered under warranty, an estimate for repair or replacement will be communicated to you via our customer service.

You will have 20 days to respond, either accepting or declining the recommendation. If you accept the recommendation for repair or replacement, you will need to provide payment. Payment can be in the form of a check, or if you prefer, by MasterCard, VISA, or American Express. If the repair or replacement is covered under warranty, you will receive no additional correspondence. Your repaired unit, or a comparable replacement of equal value and function, will be shipped to you via UPS.

## **Product Maintenance, Service and Repair**

For products that require repair or servicing (after the warranty period or when the warranty is void), customers should contact Fraser Optics Customer Service (215) 443-5240.

\* INTERNATIONAL PURCHASES: Please contact Customer Service (215) 443-5240 for instructions.

CAUTION: To avoid possible damage in transit, always use the original storage case when shipping your STEDI-EYE® stabilized binoculars. If the storage case is missing or damaged, contact Fraser Optics for special shipping instructions.

## **Manufacturer's Liability**

Fraser Optics is not responsible and assumes no liability for indirect, special or consequential damages, personal injury, property damage, or loss of property, income, or life arising from the use of its products. Users are responsible for proper training and usage of Fraser Optics products. Fraser Optics is not liable for claims of performance or product failure under any theory of tort, contract, or commercial law.





**FRASER OPTICS**  
*The Clear Advantage*

1025 Thomas Dr, Warminster, PA 18974 • Phone: (215) 443-5240 • Fax: (215) 443-0966  
E-mail: [info@fraseroptics.com](mailto:info@fraseroptics.com) • [www.fraseroptics.com](http://www.fraseroptics.com)

 Made in the USA