

# Marshall Electronics

**AR-AM4-BG**

Analog Audio Monitor



## Operating Instructions

This page left intentionally blank

# Contents

---

Product Overview .....	5
Features .....	5
Installation and Initial Setup .....	5
Unpacking .....	5
Audio Monitor Mounting .....	5
Quick Start Guide .....	6
Functional Block Diagram .....	6
Front Panel Features .....	7
Stereo Loudspeakers .....	7
Power LED .....	7
Headphone Jack .....	7
Headphone Volume .....	7
Input Select .....	7
Master Volume .....	7
Balance .....	7
USB Port .....	7
Mute Button .....	7
Phase LED .....	7
LED Bargraph Level Meter .....	7
Rear Panel Features .....	8
Power Input .....	8
RS-485 Port .....	8
Audio Output .....	8
Audio Inputs .....	8
Basic Operation .....	9
Overview .....	9
Volume Control .....	9
Channel Select .....	9
Balance Control .....	9
Headphone Output .....	9
Mute Button .....	9
Specifications .....	10
Input / Output .....	11
Warranty .....	12

This page left intentionally blank

# Product Overview

---

The **AR-AM4-BG** is a 4-channel stereo analog audio monitoring system with DSP and Peak Meters. It features stereo loudspeakers in a compact 1RU form factor, with analog amplification and digital processing. A front panel bi-color phase indicator displays the phase relationship between the left and right channels. At only 6.0" deep, the AR-AM4-BG can be installed in many shallow rack cases or placed on any level surface. This unit is enhanced with four pairs of balanced XLR inputs, along with a balanced XLR output for interfacing to downstream equipment. Controls include separate headphone and speaker volume with master balance and a front panel MUTE button. The unit's dual 10-segment bar graph meters provide the ability to visually monitor the audio source. A powerful DSP-controlled EQ (coupled with a limiting compressor) provides unparalleled, pristine sound and speaker protection.

## Features

---

- **Selectable Inputs**  
Choose between 4 independent sets of stereo inputs.
- **Superior Audio Quality**  
Stereo Loud Speakers provide superior audio quality in a compact 1RU form factor.
- **Digital Processing**  
Digital signal processing provides speaker protection.
- **Stereo Headphone Output**  
1/4" stereo headphone jack located on front panel.
- **LED Bargraph Metering**  
Tri Color LED Display of selected audio levels in stereo.
- **Audio Phase Indicator**  
Single LED to indicate 180 Degree phase errors.

## Installation and Initial Setup

---

### Unpacking

Carefully unpack the AR-AM4-BG audio monitor and verify that the following items are included:

- AR-AM4-BG Audio Monitor
- Power Supply with 4-Pin XLR Connector (24VDC)
- AC Power Cable
- Operating Instructions

Inspect the unit for any physical damage that may have occurred during shipping. Should there be any damage, immediately contact Marshall Electronics at (800) 800-6608. If you are not located within the continental United States, call +1 (310) 333-0606.

### Audio Monitor Installation

The AR-AM4-BG audio monitor can be installed in an EIA-standard 19-inch rack. At only 6" inches deep, the AR-AM4-BG can also be installed in many shallow racks cases. Alternately, the AR-AM4-BG audio monitor can be placed on any level surface. *For optimum sound quality, the audio monitor should be installed at ear level.*

# Quick Start Guide

## 1. Connect an Audio Source

Connect an audio source to any of the 4 pairs of rear panel input connectors. We recommend the use of the Balanced XLR female connectors using a balanced audio signal with a nominal level of +4dBu.

## 2. Power On the Audio Monitor

Supply power to the audio monitor by connecting the included power supply to an AC power source (100-240 V @ 50/60 Hz) and connecting the power supply's 4-pin XLR connector to the back of the audio monitor. The Power LED on the front panel will illuminate green.

## 3. Select Input Channel

Use the **Input Select** controls to choose one of the four inputs.

## 4. Adjust the Volume and Balance

Use the **Volume** and **Balance** controls to adjust the sound level and stereo balance.

# Functional Block Diagram

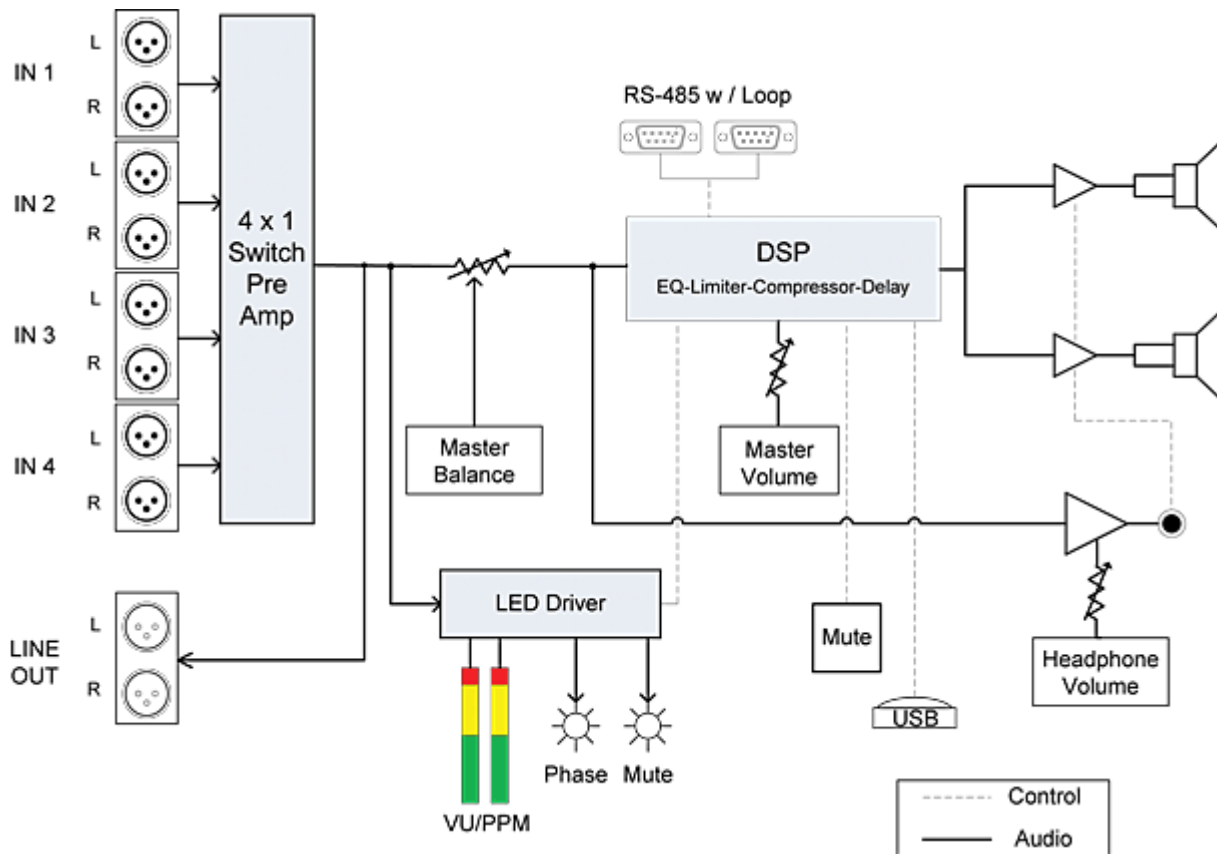

# Front Panel Features

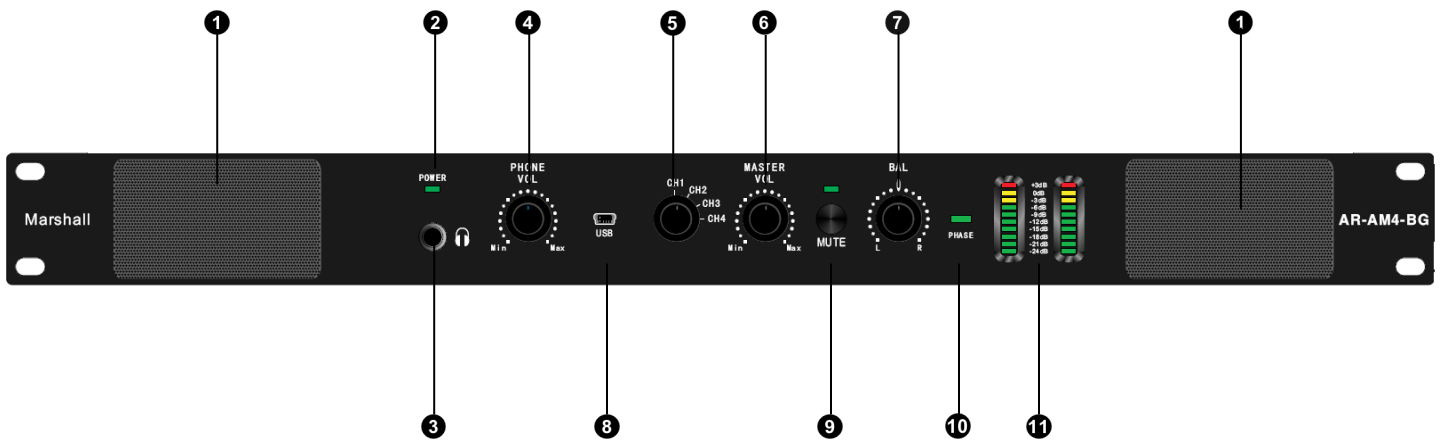

## 1 **Stereo Loudspeakers**

The stereo loudspeakers are controlled by the Master Volume Control. The sound from the selected source will be heard.

## 2 **Power Indication LED**

The power LED will illuminate green when power is supplied to the audio monitor.

## 3 **Headphone Output**

The headphone output accepts stereo headphones with a 1/4" TRS connector. When headphone plug is inserted, MUTE is activated and sound to the speakers is cut.

## 4 **Headphone Volume Control**

The headphone volume control affects only the stereo headphone jack.

## 5 **Input Select**

Rotate knob to switch between input channels 1 through 4. This selects the input source for both the speakers and headphone jack.

## 6 **Master Volume Control**

The master volume control affects only the stereo speakers.

## 7 **Balance Control**

The balance control adjusts the relative level of each left and right input to the speakers and headphones.

## 8 **USB Port**

For factory and future use only at this time.

## 9 **Mute Button**

Press to silence the speakers. The LED will light to indicate MUTE. (Headphone jack remains active)

## 10 **Phase LED**

Will indicate the wiring polarity of incoming audio comparing left to right. GREEN color indicates Left+Right is IN Phase. RED indicates a 180 Degree Phase Error between Left and Right of the selected input.

## 11 **LED Bargraph Level Meter**

Dual 10-segment LED display of selected audio source.

# Rear Panel Features

---

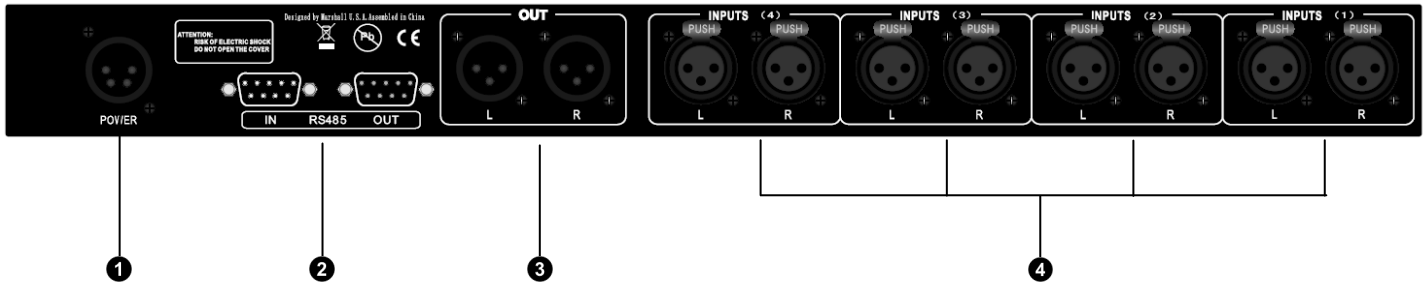

## 1 **Power Input Connector**

Use only the included power supply to power the AR-AM4-BG audio monitor.

## 2 **RS-485 Ports**

For future functions and firmware upgrades.

## 3 **Audio Outputs**

XLR- 3pin male connector. Balanced audio out is same level as XLR audio input. This is an active output from the selected Audio Input. If power is removed from the unit, there will be no signal on these connectors.

## 4 **Audio Inputs**

XLR - 3pin female connector. Balanced audio in. Pin 1= ground, Pin 2= Signal +, Pin 3= Signal -



# Basic Operation

---

## Overview

Basic operation of the AR-AM4-BG Audio Monitor involves connecting audio sources, and monitoring through the stereo speakers.

The user can choose between listening to the amplified internal speakers, or headphones. Audio volume can be adjusted from front panel controls.

There are four (4) separate stereo input channels. One can be selected at any time from the front panel.

## Controls

### ■ Volume Control

The **VOLUME** control affects only the stereo speakers.

### ■ Channel Select

The **Channel Select** controls which of the four inputs is selected to the speakers, headphones and rear XLR Outputs.

### ■ Balance Control

The **BALANCE** control adjusts the relative levels of the **LEFT** and **RIGHT** channels of the input, affecting both the stereo speakers and headphone output.

### ■ Headphone Output

The headphone output accepts standard stereo headphones with a 1/4" TRS connector. Headphones with a 1/8" (3.5mm) mini-plug connector may be used with an adapter. NOTE: The stereo speakers are muted when a connector is plugged into the headphone output. Headphones are not included with this unit.

### ■ MUTE Button

The **MUTE** button cuts the signal to the internal speakers. The LED will light to indicate the MUTE condition. Sound to the headphone jack is not affected.

# Specifications

## AR-AM4-BG Audio Monitor

### ■ ACOUSTIC

Speaker Power Output: Left/Right RMS @ 4Ω: 3W RMS, 5W Peak  
Peak Acoustic Output: 99 dB SPL @ .1m  
Headphone Power Output: 150 mW

### ■ ELECTRICAL

Power Consumption: 40W  
Voltage Requirement: 24VDC  
Included Power Supply  
AC Input: 100V-240V, 1.0A, 50-60Hz  
DC Output: 24VDC, 1.65A,

### ■ MECHANICAL

Dimensions (w x h x d): 19.0" x 1.75" x 6.0"  
Rack Height: 1 RU  
Weight: 4.55 lbs. (2 kg)

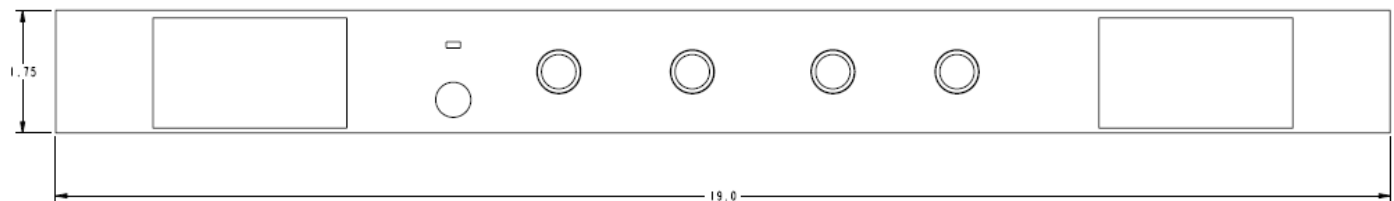
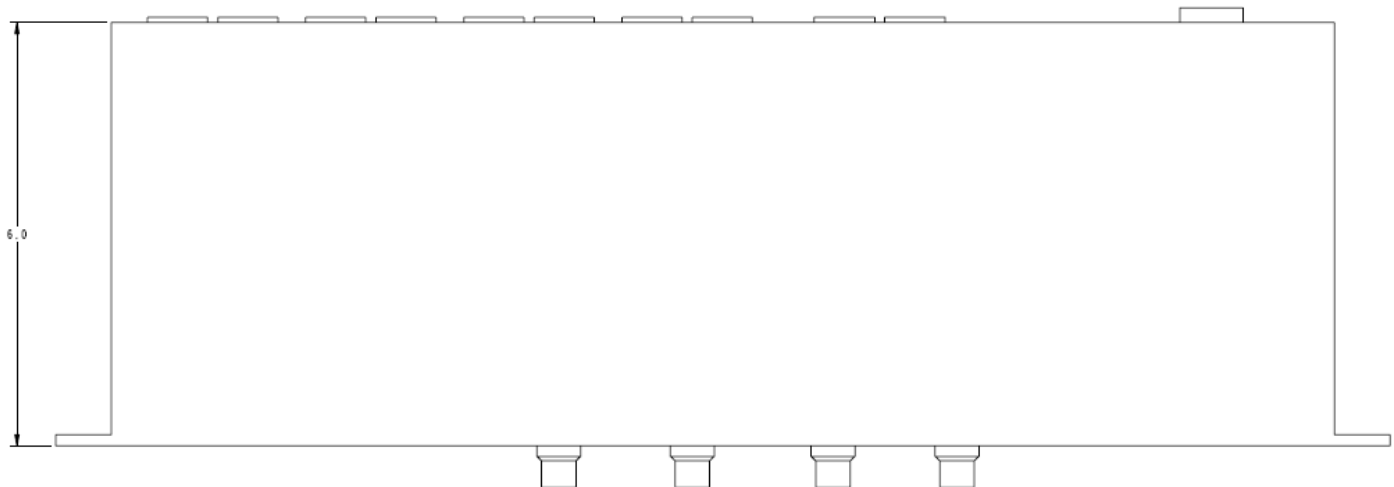

### Input / Output

- **ANALOG STEREO INPUT (x 4)**

XLR 3-pin Female +4dBu nominal level (balanced differential)

- **ANALOG STEREO OUTPUT (Selected)**

Outputs: 2 x Analog (Balanced XLR)  
Reference: Active balanced from selected Audio Input

# Warranty

---

Marshall Electronics warrants to the first consumer that this **AR-AM4-BG** Audio Monitor will, under normal use, be free from defects in workmanship and materials, when received in its original container, for a period of one year from the purchase date. This warranty is extended to the first consumer only, and proof of purchase is necessary to honor the warranty. If there is no proof of purchase provided with a warranty claim, Marshall Electronics reserves the right not to honor the warranty set forth above. Therefore, labor and parts may be charged to the consumer. This warranty does not apply to the product exterior or cosmetics. Misuse, abnormal handling, alterations or modifications in design or construction void this warranty. No sales personnel of the seller or any other person is authorized to make any warranties other than those described above, or to extend the duration of any warranties on behalf of Marshall Electronics, beyond the time period described above. Due to constant effort to improve products and product features, specifications may change without notice.

**Marshall Electronics, Inc.**

1910 East Maple Ave.  
El Segundo, CA 90245

Tel: (800) 800-6608 / (310) 333-0606 • Fax: 310-333-0688  
[www.LCDRacks.com](http://www.LCDRacks.com) • [sales@lcdracks.com](mailto:sales@lcdracks.com)